



Chipsmall Limited consists of a professional team with an average of over 10 year of expertise in the distribution of electronic components. Based in Hongkong, we have already established firm and mutual-benefit business relationships with customers from,Europe,America and south Asia,supplying obsolete and hard-to-find components to meet their specific needs.

With the principle of “Quality Parts,Customers Priority,Honest Operation,and Considerate Service”,our business mainly focus on the distribution of electronic components. Line cards we deal with include Microchip,ALPS,ROHM,Xilinx,Pulse,ON,Everlight and Freescale. Main products comprise IC,Modules,Potentiometer,IC Socket,Relay,Connector.Our parts cover such applications as commercial,industrial, and automotives areas.

We are looking forward to setting up business relationship with you and hope to provide you with the best service and solution. Let us make a better world for our industry!



Contact us

Tel: +86-755-8981 8866 Fax: +86-755-8427 6832

Email & Skype: info@chipsmall.com Web: www.chipsmall.com

Address: A1208, Overseas Decoration Building, #122 Zhenhua RD., Futian, Shenzhen, China



Switch Mode Transformers

Toroid Platform SMD



- Push Pull Converter Transformer
- Compatible with MAXIM™ MAX253 to isolate RS-485/RS232 and other industrial bus transceivers
- Compact and cost effective industrial design

Electrical Specifications @ 25°C - Operating Temperature -40°C to +125°C

Part Number ^{2,3}	Inductance (1-3) (mH ±35%)	DCR (1-3) (Ω MAX)	MAX (1-3) ¹ (V-μsec)	Turns Ratio	Isolated Voltage (Vrms)
PFX0890NL	1.02	0.60	18.4	3:4	2000

- Notes:**
- The maximum volt-use rating limits the peak flux density to 3600 gauss when used in bi-polar drive application with 200KHz. For unipolar drive applications or a bi-polar drive with 350KHz, a maximum volt-use could be 60% of the listed value.
 - Optional Tape & Reel packing can be ordered by adding a "T" suffix to the part number. Pulse complies to industry standard tape and reel specification EIA481.
 - Other turns ratios available on request.

Mechanical

Schematic

PFX0890NL

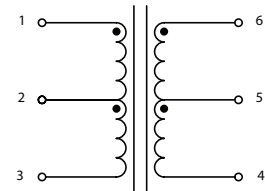
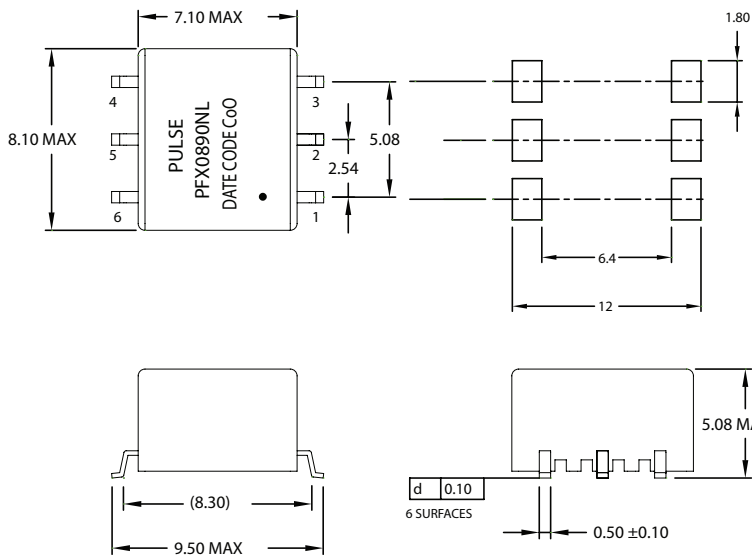

Weight0.365grams
 Tape & Reel700/reel
 Tray55/tray

Dimensions: $\frac{\text{Inches}}{\text{mm}}$

Unless otherwise specified,
 all tolerances are $\pm \frac{.010}{0,25}$

For More Information

Pulse Worldwide Headquarters
 12220 World Trade Drive
 San Diego, CA 92128
 U.S.A.

Pulse Europe
 Einsteinstrasse 1
 D-71083 Herrenberg
 Germany

Pulse China Headquarters
 B402, Shenzhen Academy of
 Aerospace Technology Bldg.
 10th Kejinan Road
 High-Tech Zone
 Nanshan District
 Shenzhen, PR China 518057

Pulse North China
 Room 2704/2705
 Super Ocean Finance Ctr.
 2067 Yan An Road West
 Shanghai 200336
 China

Pulse South Asia
 135 Joo Seng Road
 #03-02
 PM Industrial Bldg.
 Singapore 368363

Pulse North Asia
 3F, No. 198
 Zhongyuan Road
 Zhongli City
 Taoyuan County 320
 Taiwan R. O. C.
 Tel: 886 3 4356768
 Fax: 886 3 4356823 (Pulse)
 Fax: 886 3 4356820 (FRE)

Tel: 858 674 8100
 Fax: 858 674 8262

Tel: 49 7032 78060
 Fax: 49 7032 7806 135

Tel: 86 755 33966678
 Fax: 86 755 33966700

Tel: 86 21 62787060
 Fax: 86 2162786973

Tel: 65 6287 8998
 Fax: 65 6287 8998

Performance warranty of products offered on this data sheet is limited to the parameters specified. Data is subject to change without notice. Other brand and product names mentioned herein may be trademarks or registered trademarks of their respective owners. © Copyright, 2013. Pulse Electronics, Inc. All rights reserved.