



Chipsmall Limited consists of a professional team with an average of over 10 year of expertise in the distribution of electronic components. Based in Hongkong, we have already established firm and mutual-benefit business relationships with customers from,Europe,America and south Asia,supplying obsolete and hard-to-find components to meet their specific needs.

With the principle of “Quality Parts,Customers Priority,Honest Operation,and Considerate Service”,our business mainly focus on the distribution of electronic components. Line cards we deal with include Microchip,ALPS,ROHM,Xilinx,Pulse,ON,Everlight and Freescale. Main products comprise IC,Modules,Potentiometer,IC Socket,Relay,Connector.Our parts cover such applications as commercial,industrial, and automotives areas.

We are looking forward to setting up business relationship with you and hope to provide you with the best service and solution. Let us make a better world for our industry!



Contact us

Tel: +86-755-8981 8866 Fax: +86-755-8427 6832

Email & Skype: info@chipsmall.com Web: www.chipsmall.com

Address: A1208, Overseas Decoration Building, #122 Zhenhua RD., Futian, Shenzhen, China



Standard PG Step Motors

PG20L-D20-HHC0

Model Specifications

Model:	PG20L-D20-HHC0
Step Angle:	0.198 °
Drive Voltage:	DC 10.0 V
Shaft Length:	10mm
Wire Length:	300mm fly leads (no connector)
Wire Holder:	90 deg. Left
Gear Ratio:	1/91
Electrical:	10V, 350mA
	Bipolar Constant Current
	10 ohms, MS70A

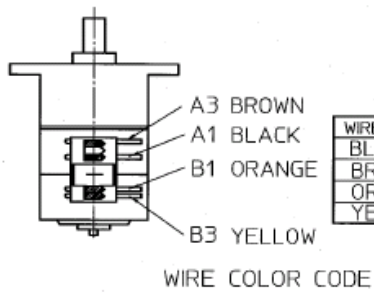
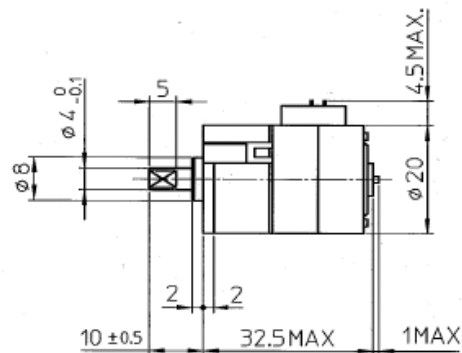
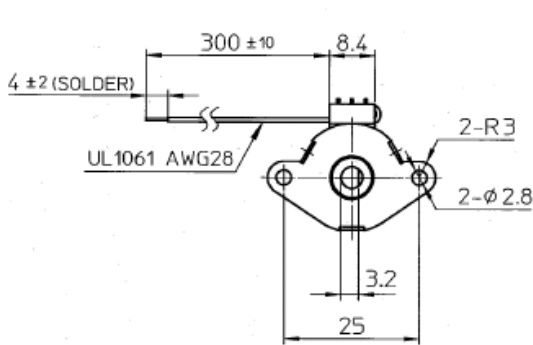

WIRE COLOR	MOTOR
BLACK	A1
BROWN	A3
ORANGE	B1
YELLOW	B3

COLOR	BLACK	BROWN	ORANGE	YELLOW
STEP 1	-	+	+	-
STEP 2	-	+	-	+
STEP 3	+	-	-	+
STEP 4	+	-	+	-

SWITCHING SEQUENCE
(VIEWED FROM MOUNTING SURFACE)

MARKING

NMB-MAT PG20L-D20-HHC0
JAPAN H0106
<JAPAN>

NMB-MAT PG20L-D20-HHC0
THAILAND TA0106
<THAILAND>

GEAR RATIO : 1 / 91

PG20L-D20-HHC0

DYNAMIC TORQUE CHARACTERISTICS (No. 63550)

(ALL VALUES ARE GAINED BY MEASUREMENT AND NOT SPECIFICATIONS VALUES)

Model : PG20L-D20-HHC0
 Drive Mode : BIPOLAR CHOPPER
 Drive Voltage : 10.0 V
 Method : 2-2P
 Drive IC : UDN2916B-V
 Surge/Current : / 350 mA / Phase (Peak)
 Coil Resistance : 10.0 Ω
 Magnet Material : MS70A
 Stator Material : SUY/SPC(Ni)
 Note : GEAR RATIO 1/91

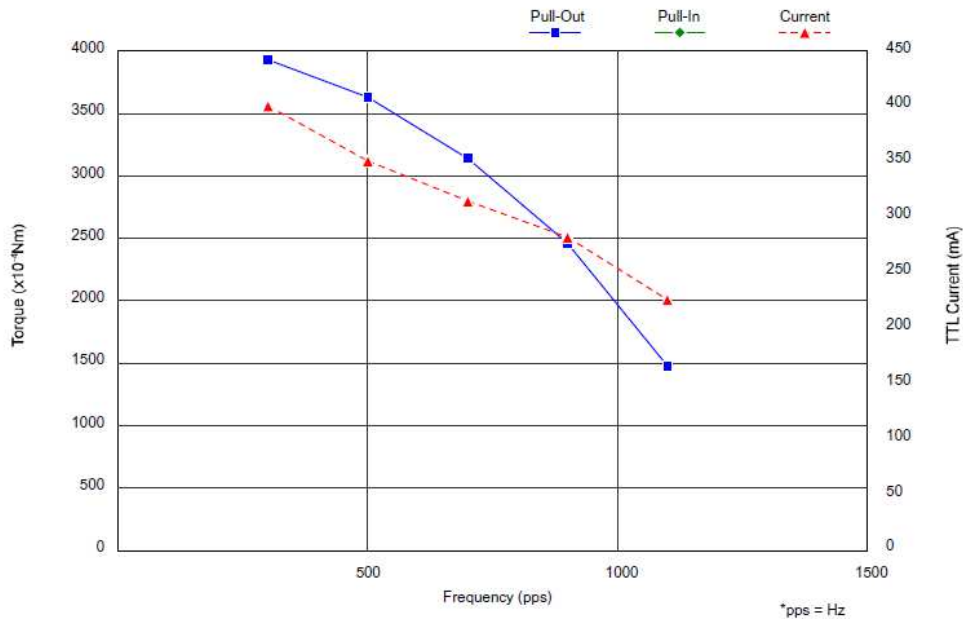

Frequency (pps)	300	500	700	900	1100
■ Pull-Out (x10 ⁻⁴ Nm)	3922.8	3628.6	3138.2	2451.8	1471.0
◆ Pull-In (x10 ⁻⁴ Nm)					
▲ Current (mA)	400	351	314	282	226