



Chipsmall Limited consists of a professional team with an average of over 10 year of expertise in the distribution of electronic components. Based in Hongkong, we have already established firm and mutual-benefit business relationships with customers from,Europe,America and south Asia,supplying obsolete and hard-to-find components to meet their specific needs.

With the principle of “Quality Parts,Customers Priority,Honest Operation,and Considerate Service”,our business mainly focus on the distribution of electronic components. Line cards we deal with include Microchip,ALPS,ROHM,Xilinx,Pulse,ON,Everlight and Freescale. Main products comprise IC,Modules,Potentiometer,IC Socket,Relay,Connector.Our parts cover such applications as commercial,industrial, and automotives areas.

We are looking forward to setting up business relationship with you and hope to provide you with the best service and solution. Let us make a better world for our industry!



Contact us

Tel: +86-755-8981 8866 Fax: +86-755-8427 6832

Email & Skype: info@chipsmall.com Web: www.chipsmall.com

Address: A1208, Overseas Decoration Building, #122 Zhenhua RD., Futian, Shenzhen, China





————— **US/UK** Page 1

————— **FR** Page 29

————— **DE** Seite 57

I A M S

**Models No. 0001 /
0011 / 0010**

Drawing No. LP0767
Version No. 104
Revision Date 15/07



IAMS 0001 / 0011 / 0010

CONTENTS

Warning!	2
Symbol identification.....	3
Safety instructions.....	3
How to dismantle the IAMS Devices	5
When front LED lights red / display shows AO.ER.....	5
Advanced features	6
Application	6
Technical characteristics	6
PGMMOD00 Display/programming front.....	7
Applications.....	8
Order codes	9
Electrical specifications.....	9
Visualisation of sensor error detection and input signal outside range	13
Sensor error detection limits.....	14
Error indications	14
connections.....	15
Block diagram	16
Setup / operating the function keys.....	17
Routing diagram.....	23
Routing diagram.....	26
Advanced settings (ADV.SET)	26
Scrolling help text in display line 3	27
Graphic depiction of relay action Setpoint	28
Graphic depiction of relay action Window.....	28



GENERAL

WARNING!

The IAMS devices are designed for connection to hazardous electric voltages.

Ignoring this warning can result in severe personal injury or mechanical damage.

To avoid the risk of electric shock and fire, the safety instructions of this manual must be observed and the guidelines followed. The specifications must not be exceeded, and the devices must only be applied as described in the following. Prior to the commissioning of the devices, this manual must be examined carefully.

Only qualified personnel (technicians) should install these devices. If the equipment is used in a manner not specified by the manufacturer, the protection provided by the equipment may be impaired.



**HAZARDOUS
VOLTAGE**

WARNING!

Until the devices are fixed, do not connect hazardous voltages to the devices.

The following operations should only be carried out on disconnected devices and under ESD safe conditions:

- General mounting, connection and disconnection of wires.
- Troubleshooting the devices.



Repair of the device must be done by Red Lion Controls only.



INSTALLATION

WARNING

To keep the safety distances, the relay contacts on the devices must not be connected to both hazardous and non-hazardous voltages at the same time.

The IAMS devices must be mounted on a DIN rail according to DIN 46277.



WARNING

Do not open the front plate of the devices as this will cause damage to the connector for the display / programming module PGMMOD00. The devices contain no DIP-switches or jumpers.

SYMBOL IDENTIFICATION



Triangle with an exclamation mark: Warning / demand. Potentially lethal situations.



The CE mark proves the compliance of the devices with the essential requirements of the directives.



The double insulation symbol shows that the devices are protected by double or reinforced insulation.

SAFETY INSTRUCTIONS

DEFINITIONS:

Hazardous voltages have been defined as the ranges: 75 to 1500 Volt DC, and 50 to 1000 Volt AC.

Technicians are qualified persons educated or trained to mount, operate, and also troubleshoot technically correct and in accordance with safety regulations.

Operators, being familiar with the contents of this manual, adjust and operate the knobs or potentiometers during normal operation.

RECEIPT AND UNPACKING:

Unpack the device without damaging it and make sure that the manual always follows the device and is always available. The packing should always follow the device until this has been permanently mounted.

Check at the receipt of the device whether the type corresponds to the one ordered.

ENVIRONMENT:

Avoid direct sunlight, dust, high temperatures, mechanical vibrations and shock, as well as rain and heavy moisture. If necessary, heating in excess of the stated limits for ambient temperatures should be avoided by way of ventilation.

All devices fall under Installation Category II, Pollution Degree 1, and Insulation Class II.

MOUNTING:

Only technicians who are familiar with the technical terms, warnings, and instructions in the manual and who are able to follow these should connect the devices.

Should there be any doubt as to the correct handling of the devices, please contact your local distributor or, alternatively, **Red Lion Controls Worldwide**

Headquarters, 20 Willow Springs Circle, York, PA 17406 USA, Phone: +1 (717) 767-6511, Fax: +1 (717) 764-0839

Mounting and connection of the devices should comply with national legislation for mounting of electric materials, i.a. wire cross section, protective fuse, and location. Descriptions of input / output and supply connections are shown in the block diagram and side label.

The following apply to fixed hazardous voltages-connected devices:

The max. size of the protective fuse is 10 A and, together with a power switch, it should be easily accessible and close to the device. The power switch should be marked with a label indicating that it will switch off the voltage to the device.

Year of manufacture can be taken from the first two digits in the serial number.

UL INSTALLATION REQUIREMENTS:

Use 60/75°C copper conducters only

For use only in pollution degree 2 or better

Max. ambient temperature..... 60°C

Max. wire size..... AWG 26-14

UL file number..... E324843

CALIBRATION AND ADJUSTMENT:

During calibration and adjustment, the measuring and connection of external voltages must be carried out according to the specifications of this manual. The technician must use tools and instruments that are safe to use.

NORMAL OPERATION:

Operators are only allowed to adjust and operate devices that are safely fixed in panels, etc., thus avoiding the danger of personal injury and damage. This means there is no electrical shock hazard, and the device is easily accessible.

CLEANING:

When disconnected, the devices may be cleaned with a cloth moistened with distilled water.

LIABILITY:

To the extent that the instructions in this manual are not strictly observed, the customer cannot advance a demand against Red Lion that would otherwise exist according to the concluded sales agreement.

HOW TO DISMANTLE THE IAMS DEVICES

First, remember to demount the connectors with hazardous voltages.

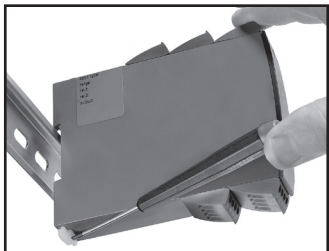

Picture 1:

Detach the device from the DIN rail by lifting the bottom lock.

When front LED lights red / display shows AO.ER

IAMS0001 and IAMS0011 are designed with a high safety level. Therefore, a continuous measurement of the outgoing current is carried out on a 4...20 mA output signal. If the current output signal is different from the internally calculated output value or the current output is 0 (due to e.g. an open circuit breakage), an error mode switches on the red front LED and disables the relays. This function is not a default option but must be actively selected via the programming menu (S4...20 & S20...4).

The error mode can only be reset by switching off and then switching on the supply voltage to the device.

IAMS 0001 / 0011 / 0010

- *Input for RTD, TC, Ohm, potentiometer, mA and V*
- *2-wire supply > 16 V*
- *FM-approved for installation in Div. 2*
- *Output for current, voltage and 2 relays*
- *Universal AC or DC supply*

Advanced features

- Programmable via detachable display front (PGMMOD00), process calibration, signal and relay simulation, password protection, error diagnostics and selection of help text in several languages.

Application

- Linearised, electronic temperature measurement with RTD or TC sensor.
- Conversion of linear resistance variation to a standard analogue current / voltage signal, i.e. from solenoids and butterfly valves or linear movements with attached potentiometer.
- Power supply and signal isolator for 2-wire transmitters.
- Process control with 2 pairs of potential-free relay contacts and analogue output.
- Galvanic separation of analogue signals and measurement of floating signals.
- The IAMS0001 and IAMS0011 have been designed according to strict safety requirements and are thus suitable for application in SIL 2 installations.

Technical characteristics

- When the devices are used in combination with the PGMMOD00 display / programming front, all operational parameters can be modified to suit any application. As the devices are designed with electronic hardware switches, it is not necessary to open them for setting of DIP-switches.
- A green / red front LED indicates normal operation and malfunction. A yellow LED is ON for each active output relay.
- Continuous check of vital stored data for safety reasons.
- 4-port 2.3 kVAC galvanic isolation.

PGMMOD00 DISPLAY / PROGRAMMING FRONT



Functionality

The simple and easily understandable menu structure and the explanatory help texts guide you effortlessly and automatically through the setup steps, thus making the product very easy to use. Functions and setup options are described in the section "Setup / operating the function keys".

Application

- Communications interface for modification of operational parameters in the IAMS devices.
- Can be moved from one device to another of the same type and download the setup of the first device to subsequent devices.
- Fixed display for readout of process data and status.

Technical characteristics

- LCD display with 4 lines; Line 1 (H=.2 inch/5.57 mm) shows input signal, line 2 (H=.2 inch/3.33 mm) shows units, line 3 (H=.13 inch/3.33 mm) shows analogue output or tag no. and line 4 shows communication and relay status.
- Programming access can be blocked by assigning a password. The password is saved in the device in order to ensure a high degree of protection against unauthorised modifications to the setup.

Mounting / installation

- Click PGMMOD00 onto the front of the device.

APPLICATIONS

Input signals:

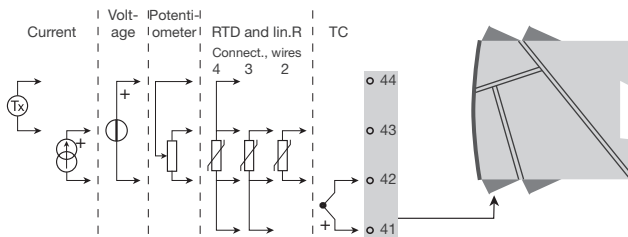

Output signals:

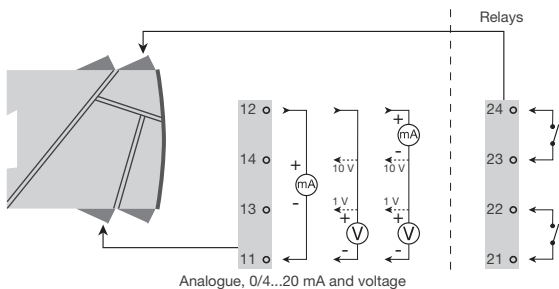

Supply:

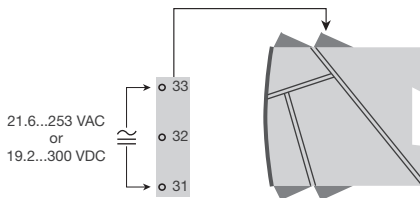

Order codes

IAMS0001	Universal transmitter with analog output
IAMS0011	Universal transmitter with analog output / 2 relays
IAMS0010	Universal limit switch with 2 relays
PGMMOD00	Display / programming module

Electrical specifications

Specifications range:

-20°C to +60°C

Common specifications:

Supply voltage, universal	21.6...253 VAC, or 19.2...300 VDC
Max. consumption.....	≤ 2.5 W
Fuse.....	400 mA SB / 250 VAC
Isolation voltage, test / operation	2.3 kVAC / 250 VAC
Communications interface	Programming front PGMMOD00
Signal / noise ratio	Min. 60 dB (0...100 kHz)
Response time (0...90%, 100...10%):	
Temperature input.....	≤ 1 s
mA / V input.....	≤ 400 ms
Calibration temperature.....	20...28°C

Display resolution: The temperature display automatically changes to tenths with values less than 1000 degrees.

Accuracy, the greater of the general and basic values:

General values		
Input type	Absolute accuracy	Temperature coefficient
All	≤ ±0.1% of span	≤ ±0.01% of span / °C

Basic values		
Input type	Basic accuracy	Temperature coefficient
mA	$\leq \pm 4 \mu\text{A}$	$\leq \pm 0.4 \mu\text{A} / ^\circ\text{C}$
Volt	$\leq \pm 20 \mu\text{V}$	$\leq \pm 2 \mu\text{V} / ^\circ\text{C}$
Pt100	$\leq \pm 0.2^\circ\text{C}$	$\leq \pm 0.01^\circ\text{C} / ^\circ\text{C}$
Linear resistance	$\leq \pm 0.1 \Omega$	$\leq \pm 0.01 \Omega / ^\circ\text{C}$
Potentiometer	$\leq \pm 0.1 \Omega$	$\leq \pm 0.01 \Omega / ^\circ\text{C}$
TC type: E, J, K, L, N, T, U	$\leq \pm 1^\circ\text{C}$	$\leq \pm 0.05^\circ\text{C} / ^\circ\text{C}$
TC type: R, S, W3, W5, LR	$\leq \pm 2^\circ\text{C}$	$\leq \pm 0.2^\circ\text{C} / ^\circ\text{C}$
TC type: B 85...200°C	$\leq \pm 4^\circ\text{C}$	$\leq \pm 0.4^\circ\text{C} / ^\circ\text{C}$
TC type: B 200...1820°C	$\leq \pm 2^\circ\text{C}$	$\leq \pm 0.2^\circ\text{C} / ^\circ\text{C}$

EMC immunity influence $< \pm 0.5\%$ of span

Extended EMC immunity:

NAMUR NE 21, A criterion, burst $< \pm 1\%$ of span

Auxiliary supplies:

2-wire supply (terminal 44...43)..... 25...16 VDC / 0...20 mA

Max. wire size..... 1 x 2.5 mm² stranded wire

Screw terminal torque..... 0.5 Nm

Relative humidity..... $< 95\%$ RH (non-cond.)

Dimensions, without display front (HxBxD).. 109 x 23.5 x 104 mm

Dimensions, with display front (HxBxD)..... 109 x 23.5 x 116 mm

Protection degree (enclosure / terminals) ... IP50 / IP20

Weight 170 g / 185 g with PGMOD00

RTD, linear resistance and potentiometer input:

Input type	Min. value	Max. value	Standard
Pt100	-200°C	+850°C	IEC60751
Ni100	-60°C	+250°C	DIN 43760
Lin. R	0 Ω	10000 Ω	-
Potentiometer	10 Ω	100 k Ω	-

Input for RTD types:

Pt10, Pt20, Pt50, Pt100, Pt200, PT250, Pt300, Pt400, Pt500, Pt1000
Ni50, Ni100, Ni120, Ni1000

Cable resistance per wire (max.), RTD..... 50 Ω
 Sensor current, RTD..... Nom. 0.2 mA
 Effect of sensor cable resistance
 (3- / 4-wire), RTD..... < 0.002 Ω / Ω
 Sensor error detection, RTD Yes
 Short circuit detection, RTD..... < 15 Ω

TC input:

Type	Min. value	Max. value	Standard
B	0°C	+1820°C	IEC 60584-1
E	-100°C	+1000°C	IEC 60584-1
J	-100°C	+1200°C	IEC 60584-1
K	-180°C	+1372°C	IEC 60584-1
L	-200°C	+900°C	DIN 43710
N	-180°C	+1300°C	IEC 60584-1
R	-50°C	+1760°C	IEC 60584-1
S	-50°C	+1760°C	IEC 60584-1
T	-200°C	+400°C	IEC 60584-1
U	-200°C	+600°C	DIN 43710
W3	0°C	+2300°C	ASTM E988-90
W5	0°C	+2300°C	ASTM E988-90
LR	-200°C	+800°C	GOST 3044-84

Cold junction compensation (CJC)
 via internally mounted sensor..... < $\pm 1,0$ °C

Sensor error detection, all TC types Yes

Sensor error current:

when detecting Nom. 2 μ A

else..... 0 μ A

Current input:

Measurement range 0...20 mA

Programmable measurement ranges..... 0...20 and 4...20 mA

Input resistance @ 20°C..... Max. 70 Ω

(20 Ω + PTC 50 Ω thermistor)

Sensor error detection:

Loop break 4...20 mA..... Yes

Voltage input:

Measurement range 0...12 VDC

Programmable measurement ranges..... 0...1 / 0.2...1 / 0...5 / 1...5 /

0...10 and 2...10 VDC

Input resistance..... Nom. 10 M Ω

Current output:

Signal range (span).....	0...20 mA
Programmable signal ranges	0...20 / 4...20 / 20...0 and 20...4 mA
Load (max.).....	20 mA / 800 Ω / 16 VDC
Load stability	$\leq 0.01\%$ of span / 100 Ω
Sensor error detection	0 / 3.5 / 23 mA / none
NAMUR NE 43 Upscale / Downscale	23 mA / 3.5 mA
Output limitation:	
on 4...20 and 20...4 mA signals	3.8...20.5 mA
on 0...20 and 20...0 mA signals	0...20.5 mA
Current limit.....	≤ 28 mA

Voltage output:

Signal range	0...10 VDC
Programmable signal ranges	0...1 / 0.2...1 / 0...10 / 0...5 / 1...5 / 2...10 / 1...0 / 1...0.2 / 5...0 / 5...1 / 10...0 og 10...2 V
Load (min.).....	500 k Ω

Relay outputs:

Relay functions.....	Setpoint, Window, Sensor error, Power and Off
Hysteresis.....	0.1...25% of span or display range
On and Off delay	0...3600 s
Sensor error detection	Break / Make / Hold
Max. voltage.....	250 VRMS
Max. current	2 A / AC or 1 A / DC
Max. AC power	500 VA

Ex / I.S. approval:

FM, applicable in.....	Class I, Div. 2, Group A, B, C, D Class I, Div. 2, Group IIC Zone 2
Max. ambient temperature for T5	60°C

Observed authority requirements:**Standard:**

EMC 2004/108/EC	
Emission and immunity.....	EN 61326-1
LVD 2006/95/EC.....	EN 61010-1
FM	3600, 3611, 3810 and ISA 82.02.01
UL, Standard for Safety	UL 508

of span = of the currently selected measurement range

Visualisation of sensor error detection and input signal outside range

Sensor error check:	
Setup	Sensor error detection:
R1, ERR.ACT=NONE - R2, ERR.ACT=NONE, OUT.ERR=NONE	OFF
Else:	ON

Outside range readout (IN.LO, IN.HI): If the valid range of the A/D converter or the polynomial is exceeded			
Input	Range	Readout	Limit
VOLT	0...1 V / 0.2...1 V	IN.LO	< -25 mV
		IN.HI	> 1.2 V
	0...10 V / 2...10 V	IN.LO	< -25 mV
		IN.HI	> 12 V
CURR	0...20 mA / 4...20 mA	IN.LO	< -1.05 mA
		IN.HI	> 25.05 mA
LIN.R	0...800 Ω	IN.LO	< 0 Ω
		IN.HI	> 1075 Ω
	0...10 k Ω	IN.LO	< 0 Ω
		IN.HI	< 110 k Ω
POTM	-	IN.LO	< -0.5 %
		IN.HI	> 100.5 %
TEMP	TC / RTD	IN.LO	< temperature range -2°C
		IN.HI	> temperature range +2°C

Display readout below min.- / above max. (-1999, 9999):			
Input	Range	Readout	Limit
All	All	-1999	Display readout <-1999
		9999	Display readout >9999

Sensor error detection limits

Sensor error detection (SE.BR, SE.SH):			
Input	Range	Readout	Limit
CURR	Loop break (4..20 mA)	SE.BR	<= 3.6 mA; > = 21 mA
POTM	All, SE.BR on all 3-wire	SE.BR	> ca. 126 k Ω
LIN.R	0...800 Ω	SE.BR	> ca. 875 Ω
	0...10 k Ω	SE.BR	> ca. 11 k Ω
TEMP	TC	SE.BR	> ca. 750 k Ω / (1.25 V)
	RTD, 2-, 3-, and 4-wire	SE.BR	> ca. 15 k Ω
	No SE.SH for Pt10, Pt20 and Pt50	SE.SH	< ca. 15 Ω

Error indications

Readout at hardware error		
Error search	Readout	Error cause
Test of internal CJC sensor	CJ.ER	CJC sensor defect or temperature outside range
Checksum test of the setup in FLASH	FL.ER	Error in FLASH
Check measurement of analogue output current	AO.ER	1) Incorrect current output (only S4...20/S20...4 mA)
Communications test PGMMOD00 / device	NO.CO	Connection error
Check that input signal matches input setup	IN.ER	1) Error levels on input
Check that saved setup in PGMMOD00 matches device	TY.ER	Setup mismatch

! Error indications in the display flash once per second. The help text explains the error.
 1) The error is reset by switching off and then switching on the supply voltage to the device.

CONNECTIONS

Supply:

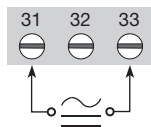

If DC power is used,
polarity does not matter

Inputs:

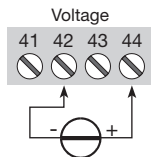
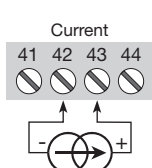
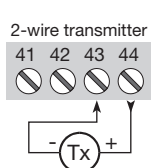
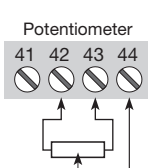
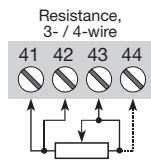
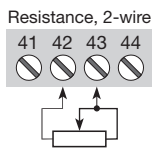
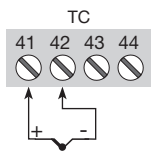
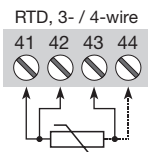
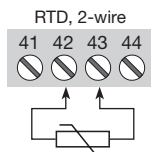

Current input
needing IAMS power

Self or externally
powered transmitter

Outputs:

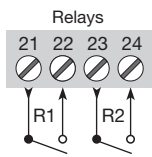
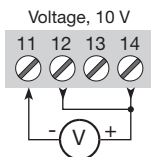
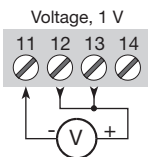
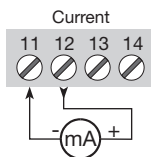

BLOCK DIAGRAM

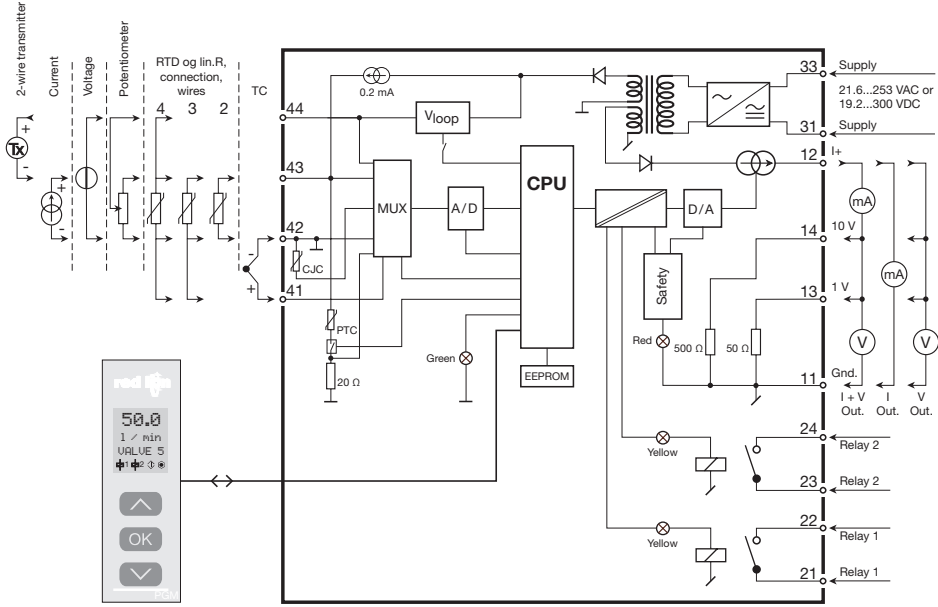



SETUP / OPERATING THE FUNCTION KEYS

Documentation for routing diagram.

In general:

When setting up the IAMS devices, you will be guided through all parameters and you can choose the settings which fit the application. For each menu there is a scrolling help text which is automatically shown in line 3 on the display.

Setup is carried out by use of the 3 function keys:

-  will increase the numerical value or choose the next parameter
-  will decrease the numerical value or choose the previous parameter
-  will save the chosen value and proceed to the next menu



When setup is completed, the display will return to the default state 1.0.

Pressing and holding  will return to the previous menu or return to the default state (1.0) without saving the changed values or parameters.

If no key is activated for 1 minute, the display will return to the default state (1.0) without saving the changed values or parameters.

Further explanations:

Fast setpoint adjustment and relay test: These menus allow you to make a quick setpoint change and relay test when the FastSet menu is activated. This function can only be activated when the relays are set for setpoint function and are controlled by a setpoint.

Pressing  and  simultaneously will activate a relay test and change the state of the relay.

Pressing  will save the setpoint change.

Holding down  for more than 1 second will return the unit to the default state without saving the setpoint change.

Password protection: Programming access can be blocked by assigning a password. The password is saved in the device in order to ensure a high degree of protection against unauthorised modifications to the setup. Default password 2008 allows access to all setup modules.

Signal and sensor error info via PGMMOD00

Sensor error (see limits in the table) is displayed as SE.BR (sensor break) or SE.SH (sensor short). Signals outside the selected range (not sensor error, see table for limits) are displayed as IN.LO indicating low input signal or IN.HI indicating high input signal. The error indication is displayed in line 3 as text and at the same time the backlight flashes. Line 4 of the display is a status line which displays status of relay 1 and relay 2, COM (flashing bullet) indicating correct functioning of PGMMOD00 and arrow up/down which indicates tendency readout of the input signal. If the figure 1 or figure 2 flashes, the unit has detected that the setpoint has been exceeded and that the relay is in “delay” mode. When the delay time has passed and the relay makes/breaks, the relay sign either displays or disappears.

Signal and sensor error indication without display front

Status of the unit can also be read from the red/green LED in the front of the device.

Green flashing LED 13 Hz indicates normal operation.

Green flashing LED 1 Hz indicates sensor error.

Steady red LED indicates internal error.

Relay functions

5 different settings of relay function can be selected.

Setpoint: The relay trips at a setpoint value with hysteresis.

Window: The relay has a window that is defined by a low and a high setpoint. On both sides of the window the relay has the same status.

Error function: The relay is activated by sensor error.

Power: The relay is activated as long as the power is on.

Off: The relay is deactivated.

Increasing/decreasing: The relays can be set to activate at increasing or decreasing input signal.

Delay: An ON and an OFF delay can be set on both relays in the range 0...3600 s.



Hysteresis: A hysteresis can be set at 0.1...25% of the span or of the selected display range.

Advanced functions

The unit gives access to a number of advanced functions which can be reached by answering "Yes" to the point "adv.set".

Display setup: Here you can adjust the brightness contrast and the backlight. Setup of TAG numbers with 6 alphanumeric. Selection of functional readout in line 3 of the display - choose between readout of analogue output or tag no.

Two-point process calibration: The unit can be process-calibrated in 2 points to fit a given input signal. A low input signal (not necessarily 0%) is applied and the actual value is entered. Then a high signal (not necessarily 100%) is applied and the actual value is entered. If you accept to use the calibration, the unit will work according to this new adjustment. If you later reject this menu point or choose another type of input signal the unit will return to factory calibration.

Process simulation function: If you agree to the point "EN.SIM" it is possible to simulate an input signal by means of the arrow keys and thus control the output signal up or down. When you finalise the point with , the unit returns to normal mode. The following point allows you to activate relay 1 and relay 2 by means of the arrow-keys up/down. You must exit the menu by pressing  (no time-out).

Password: Here you can choose a password between 0000 and 9999 in order to protect the unit against unauthorised modifications to the setup. The unit is delivered default without password. If you have locked the unit with a password by mistake, you can always open the menu by using the master password 2008.

Language: In the menu "lang.setup" you can choose between 7 different language versions of help texts that will appear in the menu. You can choose between UK, DE, FR, IT, ES, SE and DK.

Auto diagnosis

The unit performs an advanced auto diagnosis of the internal circuits.

The following possible errors can be displayed in the front unit PGMMOD00.

CJ.ER - CJC sensor defect or CJC temperature outside range

FL.ER - Flash error

AO.ER - No load on the current output (only for S4...20 mA / S20...4 mA)

NO.CO - Connection error

IN.ER - Error levels on input

TY.ER - Setup in PGMMOD00 does not match this product type or firmware revision

Selection of units

After choosing the input signal type you can choose which process units should be displayed in text line 2 (see table). By selection of temperature input the process value is always displayed in Celsius or Fahrenheit. This is selected in the menu point after selection of temperature input.

Safety readback

When the device is delivered with default configuration, the SIL function is disabled. The safety readback function (loop surveillance) can be selected in the menu O.RANGE, thus enabling the device to run in SIL mode. In order to enable the SIL functionality, the menu item S4...20 mA or S20...4 mA must be selected. Please note, however, that when safety readback is enabled, a sensor error will be indicated as an error on the analogue output signal.

Memory

In the memory menu you can save the configuration of the device in the PGMMOD00, and then move the PGMMOD00 onto another device of the same type / firmware version and download the configuration in the new device.

The display module reads the unit when plugged into the unit.

- | | |
|---------------------|---|
| No setup: | Loads to display module and exits. |
| Save memory (SAVE): | Saves the unit's program into the display module. |
| Load memory (LOAD): | Loads previously saved program in the display module to the unit. |

Power up

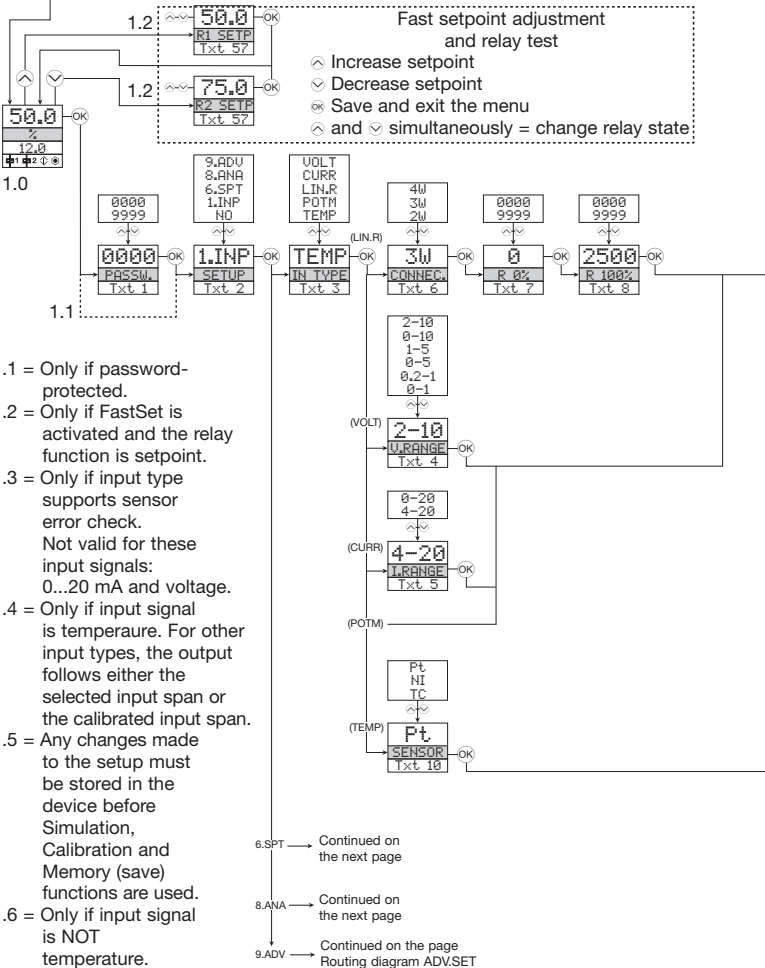

ROUTING DIAGRAM

If no key is activated for 1 minute, the display will return to the default state 1.0 without saving setup changes (except INP.SIM and REL.SIM).

- ⬆ Increase value / choose next parameter
- ⬇ Decrease value / choose previous parameter
- Ⓚ Save the chosen value and proceed to the next menu
- Hold Ⓚ Back to previous menu / return to menu 1.0 without saving

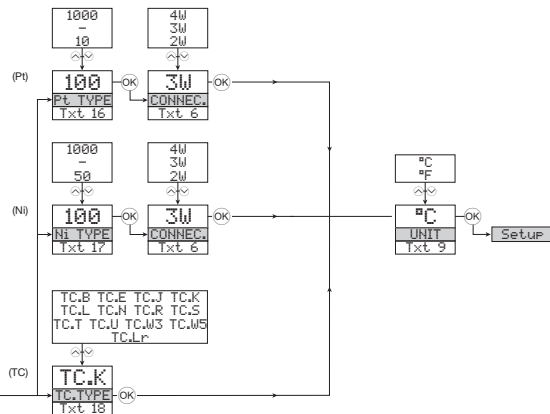
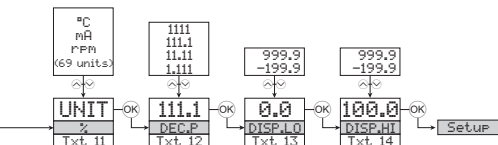

Selectable UNITS:

°C	ft/min	Hz	kg	l/min	m ³ /h	mol	pH	uS
°F	ft/s	in	kJ	l/s	m ³ /min	MPa	rPM	U
%	g	in/h	kPa	m	mA	mV	s	W
A	gal/h	in/min	kV	m/h	mbar	MW	S	Wh
bar	gal/min	in/s	kW	m/min	mils	MWh	t	yd
cm	GW	ips	kWh	m/s	min	N	t/h	[blank]
ft	hp	K	l	m/s ²	mm	Ohm	uA	
ft/h	hPa	kA	l/h	m ³	mm/s	Pa	um	

