



Chipsmall Limited consists of a professional team with an average of over 10 year of expertise in the distribution of electronic components. Based in Hongkong, we have already established firm and mutual-benefit business relationships with customers from,Europe,America and south Asia,supplying obsolete and hard-to-find components to meet their specific needs.

With the principle of “Quality Parts,Customers Priority,Honest Operation,and Considerate Service”,our business mainly focus on the distribution of electronic components. Line cards we deal with include Microchip,ALPS,ROHM,Xilinx,Pulse,ON,Everlight and Freescale. Main products comprise IC,Modules,Potentiometer,IC Socket,Relay,Connector.Our parts cover such applications as commercial,industrial, and automotives areas.

We are looking forward to setting up business relationship with you and hope to provide you with the best service and solution. Let us make a better world for our industry!



Contact us

Tel: +86-755-8981 8866 Fax: +86-755-8427 6832

Email & Skype: info@chipsmall.com Web: www.chipsmall.com

Address: A1208, Overseas Decoration Building, #122 Zhenhua RD., Futian, Shenzhen, China



PGR-3100 SERIES

Ground-Fault Indication System



Simplified Circuit Diagram

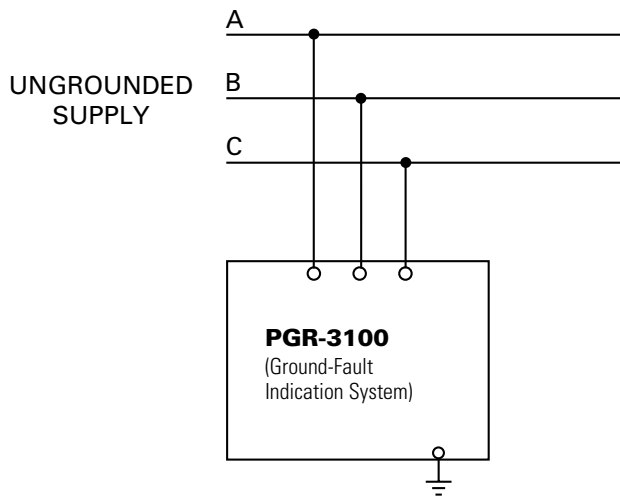

Ordering Information

ORDERING NUMBER	MOUNTING
PGR-3100	Panel mount

Description

The PGR-3100 indicates the presence of voltage on each phase of a three-phase system. The LEDs on the panel illuminate when voltage is present. When a ground-fault occurs, the voltage on the faulted phase reduces to ground potential, causing the LEDs for the faulted phase to dim and the LEDs for the unfaulted phases to become brighter. Ungrounded ac systems are required by the National Electrical Code (NEC®) Article 250.21(B) and the Canadian Electrical Code Part 1, Section 10-106 (2) to have ground detectors, such as the PGR-3100, installed on the system. External potential transformers (PTs) can be used to step down system voltage, allowing the PGR-3100 to be applied to any system voltage. PTs are not required for system voltages up to 600 Vac.

Features & Benefits

FEATURES	BENEFITS
NEC® and CEC Code compliant	Meets National Electrical Code (NEC®) Article 250.21(B) and Canadian Electrical Code Part 1, Section 10-106 (2) requirements for ungrounded systems
Phase LEDs	Indicates presence of a ground fault and the faulted phase as well as phase-to-ground voltage on an energized bus
Redundant LEDs	Redundant long-life LEDs (two per phase) to ensure reliability
Lamp test button	Verifies LEDs are operating

Specifications

Input Voltage	Up to 600 Vac 50/60 Hz
Indicator Off Voltage	< 30 Vac line to ground
Dimensions	H 88.9 mm (3.5"); W 108 mm (4.3"); D 54 mm (2.1")
Test Button	Local
Approvals	CSA certified, UL Listed
Conformally Coated	Standard feature
Warranty	5 years
Mounting	Panel