



Chipsmall Limited consists of a professional team with an average of over 10 year of expertise in the distribution of electronic components. Based in Hongkong, we have already established firm and mutual-benefit business relationships with customers from,Europe,America and south Asia,supplying obsolete and hard-to-find components to meet their specific needs.

With the principle of “Quality Parts,Customers Priority,Honest Operation,and Considerate Service”,our business mainly focus on the distribution of electronic components. Line cards we deal with include Microchip,ALPS,ROHM,Xilinx,Pulse,ON,Everlight and Freescale. Main products comprise IC,Modules,Potentiometer,IC Socket,Relay,Connector.Our parts cover such applications as commercial,industrial, and automotives areas.

We are looking forward to setting up business relationship with you and hope to provide you with the best service and solution. Let us make a better world for our industry!



Contact us

Tel: +86-755-8981 8866 Fax: +86-755-8427 6832

Email & Skype: info@chipsmall.com Web: www.chipsmall.com

Address: A1208, Overseas Decoration Building, #122 Zhenhua RD., Futian, Shenzhen, China



PI2002-EVAL1 Active ORing With Load Disconnect Evaluation Board User Guide

Contents

Introduction	Page 1
PI2002 Product Description	Page 2
Evaluation Board Terminal Description	Page 2
Evaluation Board Schematic	Page 3
Bill of Materials	Page 3
Evaluation Board Configuration	Page 4
Test Procedure	Page 4
PCB Layouts	Page 10
Evaluation Board Mechanical Drawing	Page 10

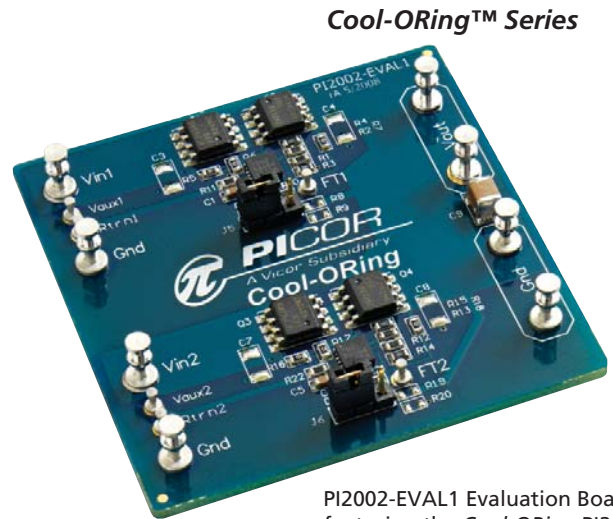

Cool-ORing™ Series

PI2002-EVAL1 Evaluation Board featuring the Cool-ORing PI2002 Active ORing controller.

The PI2002-EVAL1 Evaluation Board is intended to acquaint the user with the benefits and features of the Cool-ORing™ PI2002 Active ORing with Load Disconnect solution. It is not designed to be installed in end-use equipment.

Please read this document before setting up the PI2002-EVAL1 Evaluation Board and refer to the PI2002 product data sheet for device specifications, functional description and characteristics.

During operation, the power devices and surrounding structures can be operated safely at high temperatures.

- Remove power and use caution when connecting and disconnecting test probes and interface lines to avoid inadvertent short circuits and contact with hot surfaces.
- When testing electronic products always use approved safety glasses. Follow good laboratory practice and . . . procedures.

Introduction

The PI2002-EVAL1 allows the user to test the basic principle and operational characteristics of an Active ORing with Load Disconnect function in a redundant power architecture, while also experiencing the benefits and value of the PI2002 solution versus conventional Active ORing solutions. The PI2002-EVAL1 evaluation board is configured to receive two independent power source inputs, per a typical redundant power architecture, through two Active ORing channels that are combined to form a redundant power output. Each channel contains a PI2002 controller and two N-channel power MOSFETs (configured back-to-back). The MOSFET footprints can take SO-8 or Power SO-8 MOSFET packages. Each channel is capable of up to 20 A.

The PI2002-EVAL1 evaluation board is designed with optimized PCB layout and component placement to represent a realistic high density final design for an embedded Active ORing with Load Disconnect solution for ≤ 7 Vbus

applications requiring up to 20 A. This evaluation board is intended as an easy and simple way to test the electrical and thermal performance of the PI2002 Active ORing with Load Disconnect controller.

Both dynamic and steady state testing of the PI2002 can be completed on the PI2002-EVAL1 evaluation board, in addition to using the key features of the product. Dynamic testing can be completed under a variety of system level fault conditions to check for response time to faults.

This document provides basic instructions for initial start-up and configuration of the evaluation board. Further information on the functionality of the PI2002 can be found in the PI2002 product data sheet.

Cool-ORing™ PI2002 Product Description

The Cool-ORing™ PI2002 with two external back-to-back configured industry standard N-channel MOSFETs is a complete Active ORing solution that also provides a Load Disconnect feature designed for use in redundant power system architectures. The PI2002 controls back-to-back MOSFETs providing true bi-directional switch capabilities to protect against both power source and load fault conditions.

The gate drive output turns the MOSFETs on in normal steady state operation, while achieving high-speed turn-off under a variety of potential system-level fault conditions, per conventional Active ORing solutions with auto-reset once the fault clears. The PI2002 has the added benefit of being able to protect against output load fault conditions that may induce excessive forward current and device over-temperature by removing gate drive from the MOSFETs with an auto-retry programmable off-time. The back-to-back MOSFETs drain-to-drain voltage is monitored to detect normal forward, excessive forward, light load and reverse current flow. The PI2002 provides an active low fault flag output to the system during excessive forward current, reverse current, light load, under-voltage, over-voltage and over-temperature. A temperature sensing function turns off the MOSFETs and indicates a fault if the junction temperature exceeds 145°C.

Figure 1 shows a photo of the PI2002-EVAL1 evaluation board, with two PI2002 controllers and four N-channel MOSFETs used to form the two Active ORing channels that also feature a Load Disconnect function. The board is built

with two identical Active ORing circuits with options and features that enable the user to fully explore the capabilities of the PI2002 universal Active ORing with Load Disconnect controller.

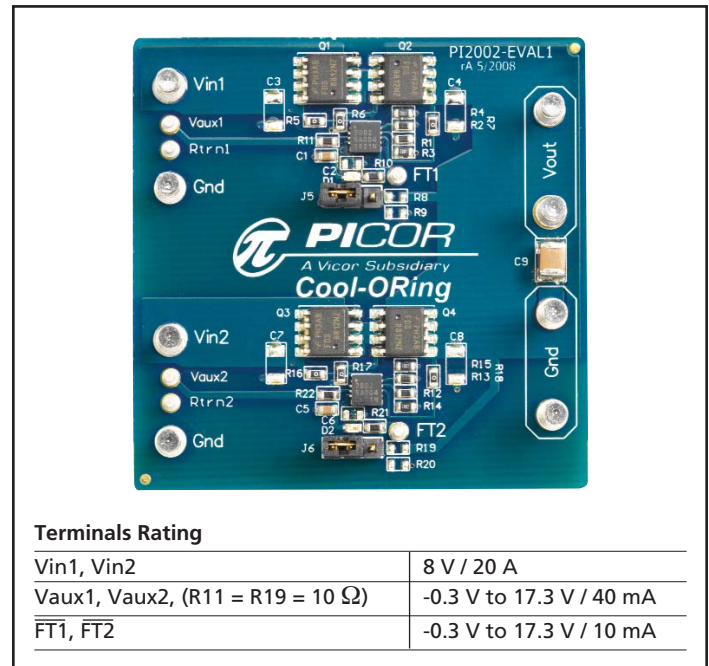

Terminals Rating

Vin1, Vin2	8 V / 20 A
Vaux1, Vaux2, (R11 = R19 = 10 Ω)	-0.3 V to 17.3 V / 40 mA
FT1, FT2	-0.3 V to 17.3 V / 10 mA

Figure 1 – PI2002-EVAL1 Evaluation Board (1.8" x 1.8")

Terminal	Description
Vin1	Power Source Input #1 or bus input designed to accommodate up to 20 A continuous current.
Vaux1	Auxiliary Input Voltage #1 to supply PI2002 VC power. Vaux1 should be equal to Vin1 plus 5 V or higher. See details in Auxiliary Power Supply (Vaux) section of the PI2002 data sheet.
Rtn1	Vaux1 Return Connection: Connected to Ground plane
Gnd	Vin & Vout Return Connection: Three Gnd connections are available and are connected to a common point, the Ground plane. Input supplies Vin1 & Vin2 and the output load at Vout should all be connected to their respective local Gnd connection.
Vin2	Power Source Input #2 or bus input designed to accommodate up to 20 A continuous current.
Vaux2	Auxiliary Input Voltage #2 to supply PI2002 VC power. Vaux2 should be equal to Vin2 plus 5 V or higher. See details in Auxiliary Power Supply (Vaux) section of the PI2002 data sheet.
Rtn2	Vaux2 Return Connection: Connected to Ground plane
FT1	PI2002 (U1) Fault Pin: Monitors U1 fault conditions
FT2	PI2002 (U2) Fault Pin: Monitors U2 fault conditions
Vout	Output: Q2 and Q4 MOSFET Drain pins connection, connect to the load high side.

Table 1 – PI2002-EVAL1 Evaluation Board terminals description

Jumper	Description
J5, J6	SCD Jumpers: Connect jumper across the two pins to the input side (GND) for maximum Gate charge current or across the two pins on the output side to connect to the resistive voltage divider to the output.

Table 2 – PI2002-EVAL1 Evaluation Board jumpers description

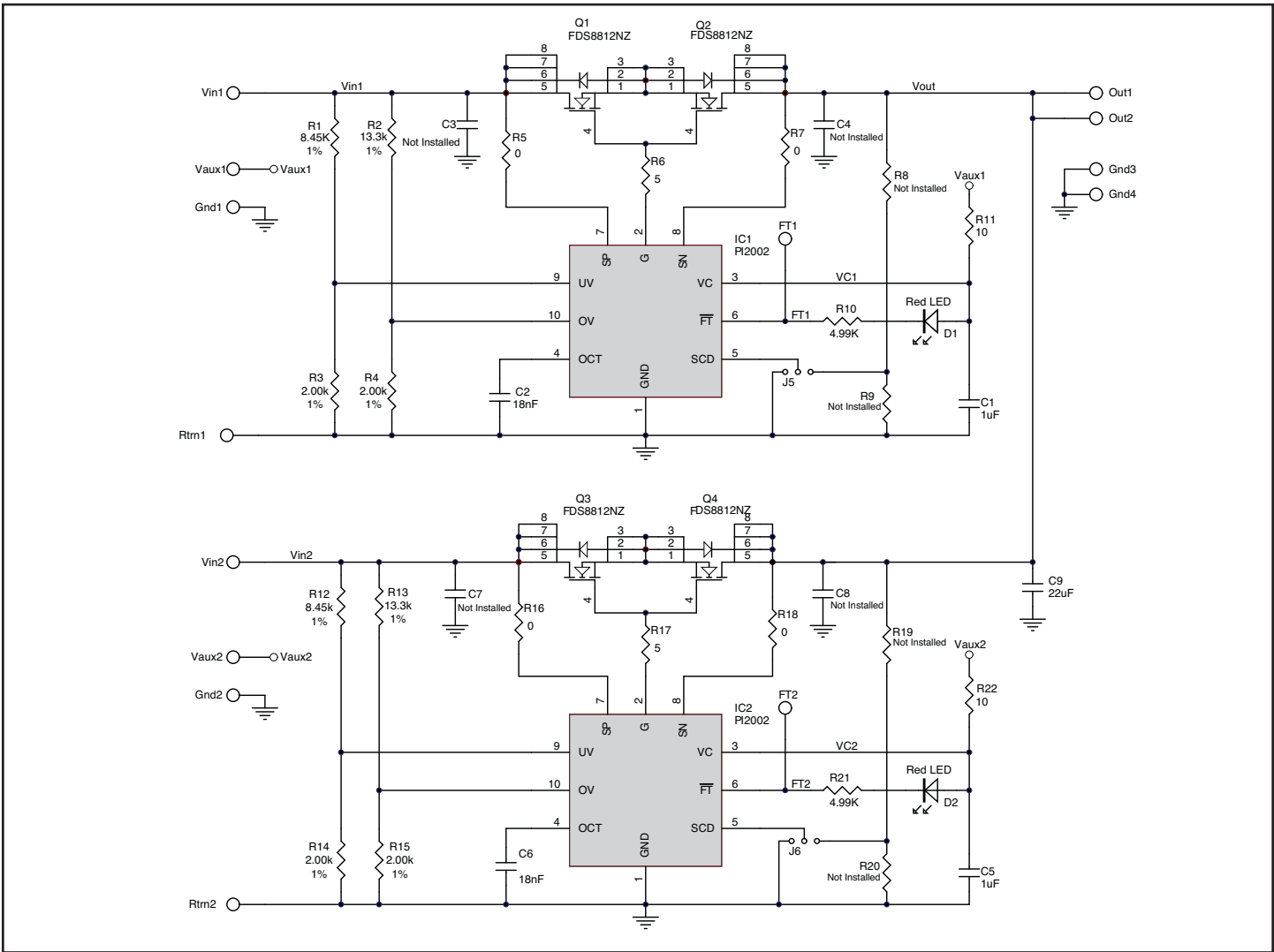

Figure 2 – PI2002-EVAL1 Evaluation Board schematic.

Item	QTY	Reference Designator	Value	Description	Footprint	Manufacturer
1	2	C1, C2	1 μ F	Capacitor, MLCC X5R, 1 μ F, 16 V	0603	
2	1	C9	22 μ F	Capacitor, MLCC X7R, 22 μ F, 25 V	1210	
3	4	C3, C4, C7, C8	Not installed	Not installed	1206	
4	2	C2, C3	18 nF	Capacitor, MLCC X5R, 18 nF, 25 V	0603	
5	2	D1, D2		LED, Super Red	THIN 0603	Lite-On, Inc.,
6	6	FT1, FT2, Rtn1, Rtn2, Vaux1, Vaux2		Turret Test point	TURRET-1528	Keystone Electronics
7	8	Gnd1, Gnd2, Gnd3, Gnd4, Vin1, Vin2, Vout1, Vout2		Turret Test point	TURRET-1502	Keystone Electronics
8	2	J5, J6		Header Pins 0.1" pitch	2 x 3mm	
9	4	Q1, Q2, Q3, Q4		FDS8812NZ 30 V, 20 A, N-MOSFET	SO-8	Fairchild
10	2	R1, R12	8.45 K Ω	Resistor, 8.45 K Ω , 1%	0603	
11	2	R2, R13	13.3 K Ω	Resistor, 13.3 K Ω , 1%	0603	
12	4	R3, R4, R14, R15	2.00 Ω	Resistor, 2.00 Ω , 1%	0603	
13	6	R5, R6, R7, R16, R17, R18	0 Ω	Resistor, 0 Ω	0603	
14	2	R8, R9, R19, R20	Not Installed	Not Installed	0603	
15	2	R10, R21	4.99 k Ω	Resistor, 4.99 Ω , 5%	0603	
16	2	R11, R22	10 Ω	Resistor, 10 Ω , 5%	0603	
17	2	U1, U2	PI2002	Picor Active ORing with Load Disconnect Controller	3 mm x 3 mm; 10-TDFN	PICOR

Table 3 – PI2002-EVAL1 Evaluation Board bill of materials

Reference Designator	Value	Functional Description
C1, C5	1 μ F	VC Bypass Capacitor
C9	22 μ F	Output (Load) Capacitor
C3, C4, C7, C8	Not installed	Snubber to reduce voltage ringing when the device turns off
C2, C6	18 nF	OCT off timer Capacitor
D1, D2	LED	To indicate a fault exist when it is on
J5, J6	Jumper	SCD to select for Gate high charge current or Gate low charge current
Q1, Q2, Q3, Q4	N-MOSFET	ORing Main Switch
R1, R12	8.45 K Ω	UV Voltage Divider Resistor (R2UV in Figure 4)
R2, R13	13.3 K Ω	OV Voltage Divider Resistor (R2OV in Figure 4)
R11, R22	10 Ω	VC Bias resistor
R10, R21	4.99 K Ω	LED Current Limiter
R3, R14	2.00 K Ω	UV Voltage Divider Resistor (R1UV in Figure 4)
R4, R15	2.00 K Ω	OV Voltage Divider Resistor (R1OV in Figure 4)
R7, R14	Not Installed	SCD Ground connecting Resistor
U1, U2	PI2002	Picor Active ORing with Load Disconnect Controller

Table 4 – Component functional description

Initial Test Set Up

To test the PI2002-EVAL1 evaluation board it is necessary to configure the jumpers (J5 and J6) first based on the required board configuration.

Failure to configure the jumpers prior to the testing may result in improper circuit behavior.

Baseline Test Procedure (Refer to Figure 3)

1.0 Recommended Equipment

- 1.1 Two DC power supplies - 0-10 V; 25 A.
- 1.2 DC power supply 12 V; 100 mA.
- 1.3 DC electronic load - 30 A minimum.
- 1.4 Digital Multimeter
- 1.5 Oscilloscope.
- 1.6 Appropriately sized interconnect cables.
- 1.7 Safety glasses.
- 1.8 PI2002 Product Data sheet.

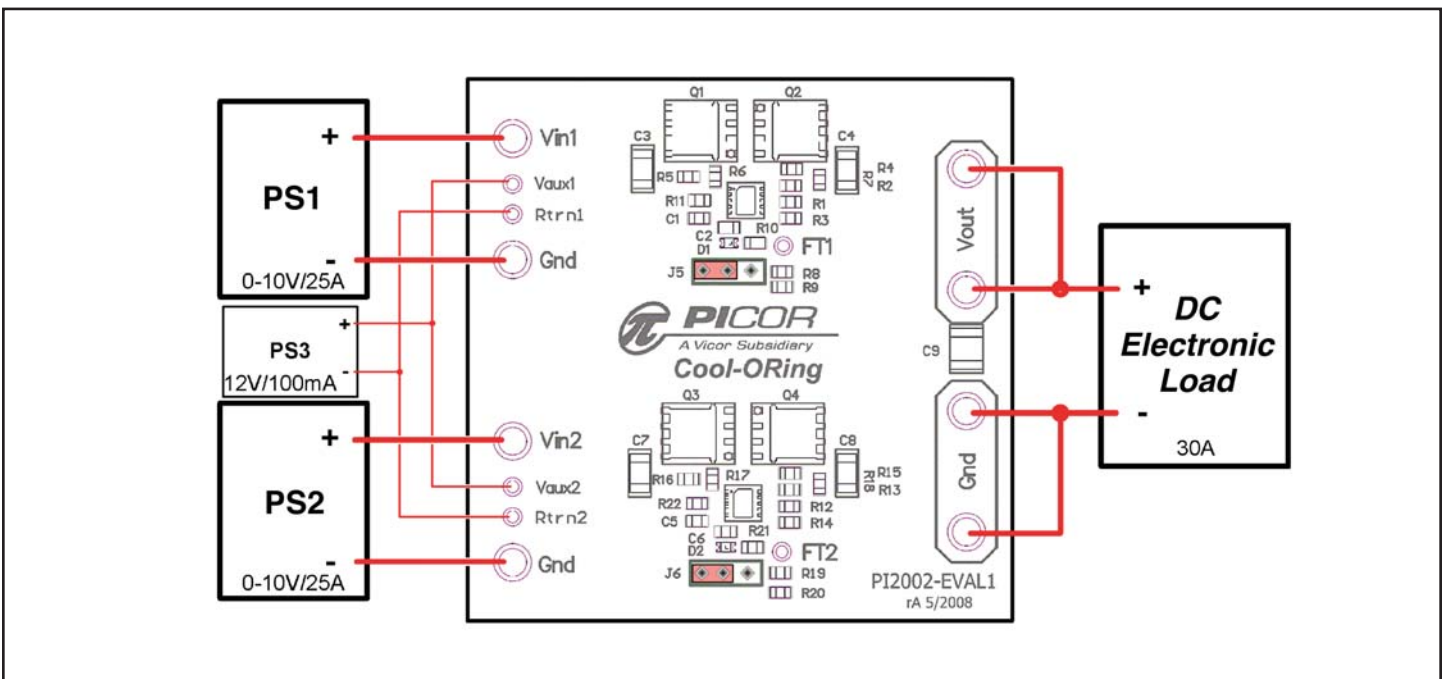

Figure 3 – Layout configuration for a typical redundant power application, OCD configured for fast gate turn on.

Before initial power-up follow these steps to configure the evaluation board for specific end application requirements:

2.0 Undervoltage (UV) and Overvoltage (OV) resistors set up:

2.1 UV and OV programmable resistors are configured for a 3.3 V Vin (BUS voltage) application in a two-resistor voltage divider configuration as shown in Figure 4. UV is set to 2.6 V and OV is set for 3.8 V, R1ov and R1uv are 2.00 KΩ 1%. If PI2002-EVAL1 is required to be used in a different Vin voltage application please follow the following steps to change the resistor values.

2.1.1 It is important to consider the maximum current that will flow in the resistor divider and maximum error due to UV and OV input current.

$$R1_{UV} = \frac{V(UV_{TH})}{I_{RUV}}$$

2.1.2 Set R1uv and R1ov value based on system allowable minimum current and 1% error; $I_{RUV} \geq 100 \mu A$

$$R2_{UV} = R1_{UV} \left(\frac{V(UV)}{V(UV_{TH})} - 1 \right)$$

Where:

V(UV_{TH}) : UV threshold voltage

V(UV) : UV voltage set (0.5 V typ)

I_{RUV}: R1_{UV} current

$$R2_{OV} = R1_{OV} \left(\frac{V(OV)}{V(OV_{TH})} - 1 \right)$$

Where:

V(OV_{TH}) : OV threshold voltage

V(OV) : OV voltage set (0.5 V typ)

I_{ROV}: R1_{OV} current

2.1.3 Example for 2.0 V Vin (BUS voltage), to set UV and OV for ±10% Vin set UV at 1.8 V and OV at 2.2 V.

$$R2_{UV} = R1_{UV} \left(\frac{V(UV)}{V(UV_{TH})} - 1 \right) = 2.00 \text{ K}\Omega * \left(\frac{1.8 \text{ V}}{0.5 \text{ V}} - 1 \right) = 5.20 \text{ K}\Omega \text{ (or } 5.23 \text{ K}\Omega \text{ \% standard value)}$$

$$R2_{OV} = R1_{OV} \left(\frac{V(OV)}{V(OV_{TH})} - 1 \right) = 2.00 \text{ K}\Omega * \left(\frac{2.2 \text{ V}}{0.5 \text{ V}} - 1 \right) = 6.80 \text{ K}\Omega \text{ (or } 6.81 \text{ K}\Omega \text{ \% standard value)}$$

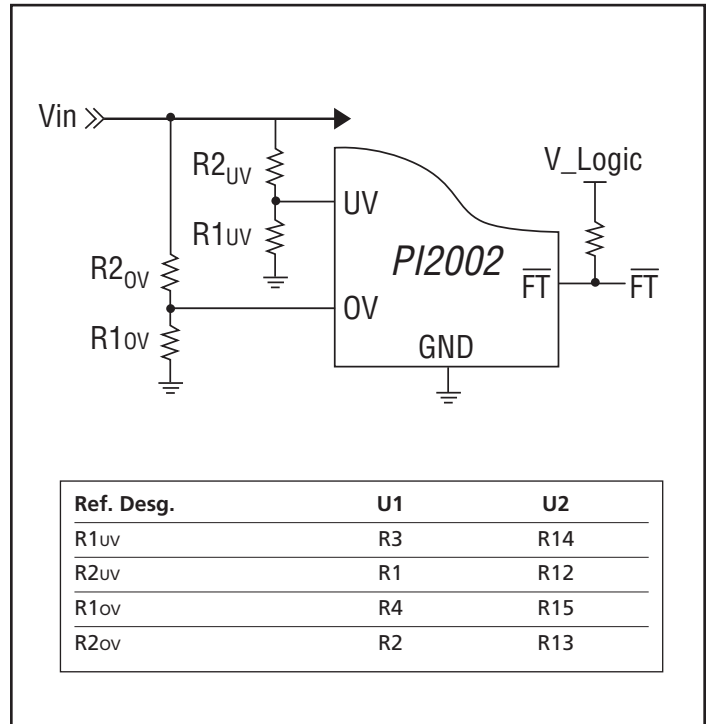

Figure 4 – UV & OV two-resistor divider configuration

3.0 Over Current Timer: OCT

The OCT off-time is set with the OCT capacitor, where the specific value can be determined from Figure 5. Every time an overcurrent condition occurs the PI2002 pulls the Gate pin low, discharges the OCT capacitor and then starts to charge it again over the programmed off-time. Only when the OCT capacitor voltage reaches the OCT threshold (1.75 V) will the Gate pin then start to charge the MOSFET gates.

4.0 Short Circuit Detect: SCD

SCD pin can be connected to the load directly or programmed to a higher voltage with a resistor divider. SCD function allows the user to define the (Hard Short) voltage level expected if a non-ideal short circuit occurs at the load. This feature enables distinguishing between a faulted load versus powering capacitive and low resistive loads without entering the OCT mode. This pin can be grounded to provide a fast gate charge or pulled to Vc for lower gate current to drive highly capacitive loads with resulting slow gate charge under the fault condition.

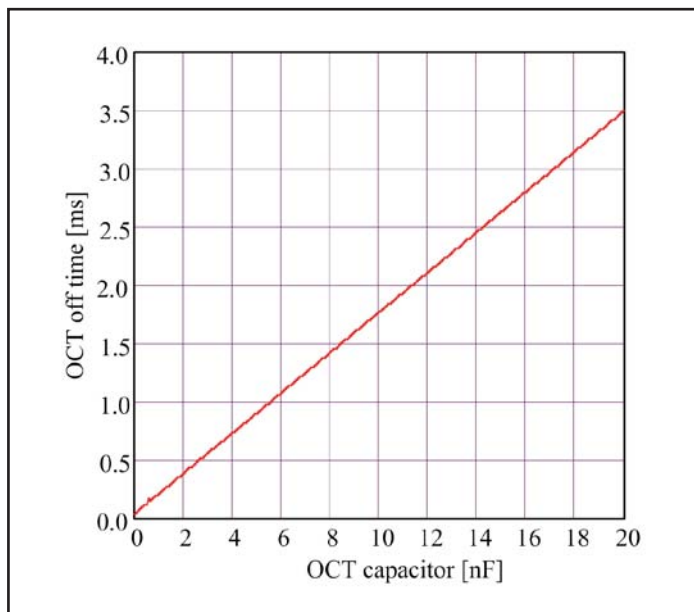

Figure 5 – OCT off time vs. OCT capacitor value

5.0 Auxiliary Power Supply (Vaux):

- 5.1 The PI2002 Controller has a separate input (VC) that provides power to the control circuitry and the gate driver. An internal voltage regulator (VC) clamps the VC voltage to 15.5 V typically.
- 5.2 Connect independent power source to Vaux inputs of PI2002-EVAL1 Evaluation Board to supply power to the VC input. The Vaux voltage should be 5V higher than Vin (redundant power source output voltage) to fully enhance the MOSFET. If the MOSFET is replaced with a different MOSFET, make sure that the Vaux voltage is equal to Vin + 0.5 V + the required voltage to enhance the MOSFET.
- 5.3 10 Ω bias resistors (Rbias, reference designators R11 and R22) are installed on the PI2002-EVAL1 between each Vaux input and VC pin of one of the PI2002 controller.
- 5.4 If Vaux is higher than the Clamp voltage, 15.5 V typical, the Rbias value has to be changed using the following equations:

- 5.4.1 Select the value of Rbias using the following equations:

$$R_{\text{bias}} = \frac{V_{\text{auxmin}} - V_{\text{CclampMAX}}}{I_{\text{Cmax}}}$$

- 5.4.2 Calculate Rbias maximum power dissipation:

$$P_{dR_{\text{bias}}} = \frac{(V_{\text{auxmax}} - V_{\text{CclampMIN}})^2}{I_{\text{Cmax}}}$$

Where:

Vauxmin : Vaux minimum voltage

Vauxmax : Vaux maximum voltage

VCclampMAX : Maximum controller clamp voltage, 16.0 V

VCclampMIN : Minimum controller clamp voltage, 14.0 V

ICmax : Controller maximum bias current, use 4.2 mA

5.4.3. For example, if the minimum $V_{aux} = 22\text{ V}$ and the maximum $V_{aux} = 28\text{ V}$

$$R_{bias} = \frac{V_{auxmin} - V_{CclampMAX}}{I_{Cmax}} = \frac{22\text{ V} - 16\text{ V}}{4.2\text{ mA}} = 1.429\text{ K}\Omega, \text{ use } 1.43\text{ K}\Omega\text{ } 1\%\text{ resistor}$$

$$P_{dRbias} = \frac{(V_{auxmax} - V_{CclampMIN})^2}{R_{bias}} = \frac{(28\text{ V} - 14.0\text{ V})^2}{1.43\text{ K}\Omega} = 137\text{ mW}$$

Note: Minimize the resistor value for low V_{aux} voltage levels to avoid a voltage drop that may reduce the VC voltage lower than required to drive the gate of the internal MOSFET.

6.0 Hook Up of the Evaluation Board

- 6.1 OV and UV resistors values are configured for a 3.3 V input voltage. If you are using the evaluation board in a different input voltage level you have to adjust the resistor values by replacing R1, R2, R12 and R13, or remove R2, R3, R13 and R14 to disable UV and OV. Please refer to the UV/OV section for details to set R1, R2, R12 and R13 proper values.
- 6.2 Verify that the jumpers J5 and J6 are installed for high gate current [across the two pins at Vin side].
- 6.3 Connect the positive terminal of PS1 power supply to Vin1. Connect the ground terminal of PS1 to its local Gnd. Set the power supply to 3.3 V. Keep PS1 output disabled (OFF).
- 6.4 Connect the positive terminal of PS2 power supply to Vin2. Connect the ground terminal of PS2 to its local Gnd. Set the power supply to 3.3 V. Keep PS2 output disabled (OFF).
- 6.5 Connect the positive terminal of PS3 power supply to Vaux1 and Vaux2. Connect the ground terminal of this power supply to Rtn1 and Rtn2. Set the power supply to 12 V. Keep PS3 output disabled (OFF).
- 6.6 Connect the electronic load to the output between Vout and Gnd. Set the load current to 10 A.
- 6.7 Enable (turn ON) PS1 power supply output.
- 6.8 Turn on the electronic load.
- 6.9 Verify that the electronic load input voltage reading is 0V.
- 6.10 Enable (turn ON) PS3 power supply output.
- 6.11 Verify that the electronic load voltage reading is few millivolts below 3.3 V. This verifies that the MOSFETs are in conduction mode.
- 6.12 D1 should be off. This verifies that there is no fault condition.
- 6.13 Reduce PS1 output voltage to 2 V,
- 6.14 D1 should turn on, and the output voltage is 0V, this verifies that the circuit is in an under-voltage fault condition and the MOSFETs are turned off.
- 6.15 Increase PS1 output to 3.3 V, D1 should turn off and output voltage is 3.3V. Then increase PS1 output to 4 V, D1 should turn on indicating an over-voltage fault condition and output voltage should go to 0 V indicating that the MOSFETs are turned off.
- 6.16 Verify that Vin2 is at 0 V. This verifies that the PI2002 (U2) MOSFETs are off.
- 6.17 D2 should be on. This is due to a reverse voltage fault condition caused by the bus voltage being high with respect to the input voltage (Vin2).
- 6.18 Enable (turn ON) PS2 output.
- 6.19 Verify that both PS1 and PS2 are sharing load current evenly by looking at the supply current.
- 6.20 Disable (turn OFF) PS1, PS2 and PS3 outputs.
- 6.21 Enable (turn ON) PS2 output then Enable PS3 output.
- 6.22 Verify that the electronic load voltage reading is few millivolts below 3.3 V. This verifies that the MOSFET is in conduction mode.
- 6.23 D2 should be off. This verifies that there is no fault condition.
- 6.24 Reduce PS2 output voltage to 2 V,
- 6.25 D2 should turn on, and the output voltage is 0V, this verifies that the circuit is in an under-voltage fault condition and the MOSFETs are turned off.
- 6.26 Increase PS2 output to 3.3 V, D2 should turn off and output voltage goes back to 3.3V. Then increase PS2 output to 4 V, D2 should turn on indicating an over voltage fault condition and output voltage goes to 0V indicating that its MOSFETs are off.
- 6.27 Verify that Vin1 is at 0V. This verifies that the MOSFETs (Q1 and Q2) are off.
- 6.28 D1 should be on. This is due to a reverse voltage fault condition caused by the output voltage being high with respect to the input voltage (Vin1).

7.0 Output short circuit test

7.1 Apply a short at one of the outputs. The short can be applied electronically using a MOSFET connected between Vout and Gnd or simply by connecting Vout to Gnd. Monitor the voltage across the MOSFETs [V(D1) – V(D2)] with differential probe if available. Then measure the response time between when

[V(D1) – V(D2)] reaches the forward overcurrent threshold (114 mV) and when the MOSFETs are disconnected (or turned off). An example for PI2002 response time to an output short circuit is shown in Figure 6.

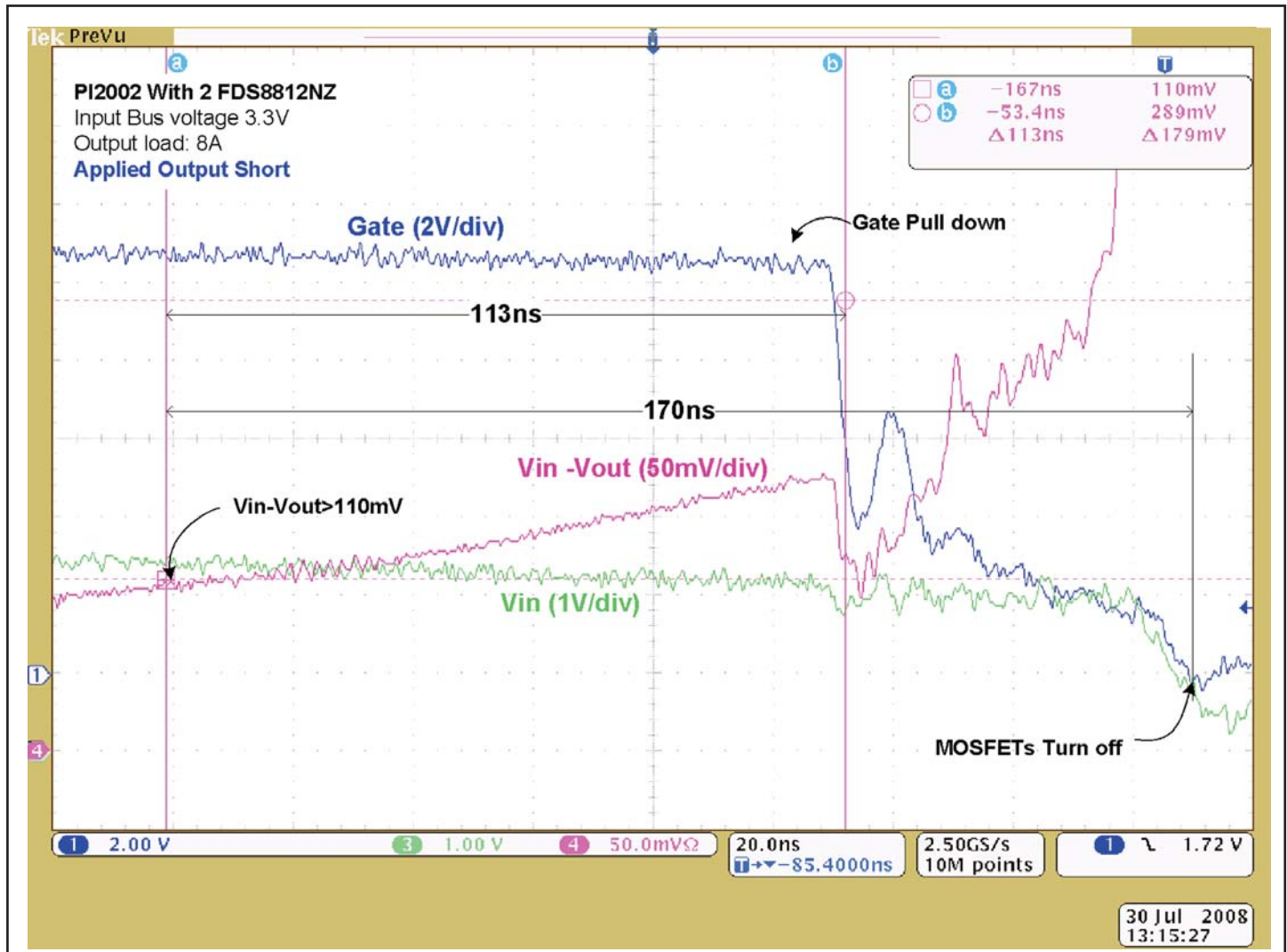

Figure 6 – Plot of PI2002 response time to forward overcurrent detection

8.0 Input short circuit test

- 8.1 To emulate a real application, the BUS supplies for this test should have a solid output source such as DC-DC converter that supplies high current and can be connected very close to the evaluation board to reduce stray parasitic inductance. Or use the prospective supply sources of the end application where the PI2002 will be used.
- 8.2 Stray parasitic inductance in the circuit can contribute to significant voltage transient conditions, particularly when the MOSFETs are turned-off after a reverse current fault has been detected. When a short is applied at the output of the input power sources and the evaluation board input (Vin), a large reverse current is sourced from the evaluation board output through the ORing MOSFETs. The reverse current in the MOSFET may reach over 60 A in some conditions before the MOSFETs are turned off. Such high current

conditions will store high energy even in a small parasitic element, and can be represented as $\frac{1}{2} Li^2$. A 1 nH parasitic inductance with 60 A reverse current will generate 1.8 μ J. When the MOSFETs are turned off, the stored energy will be released and will produce a high negative voltage at D1 and high positive voltage at D2. This event will create a high voltage difference across the MOSFETs.

- 8.3 Apply a short at one of the inputs (Vin1 or Vin2). The short can be applied electronically using a MOSFET connected between Vin and Gnd or simply by connecting Vin to Gnd. Then measure the response time between when the short is applied and the MOSFETs are disconnected (or turned off). An example for PI2002 response time to an input short circuit is shown in Figure 7.

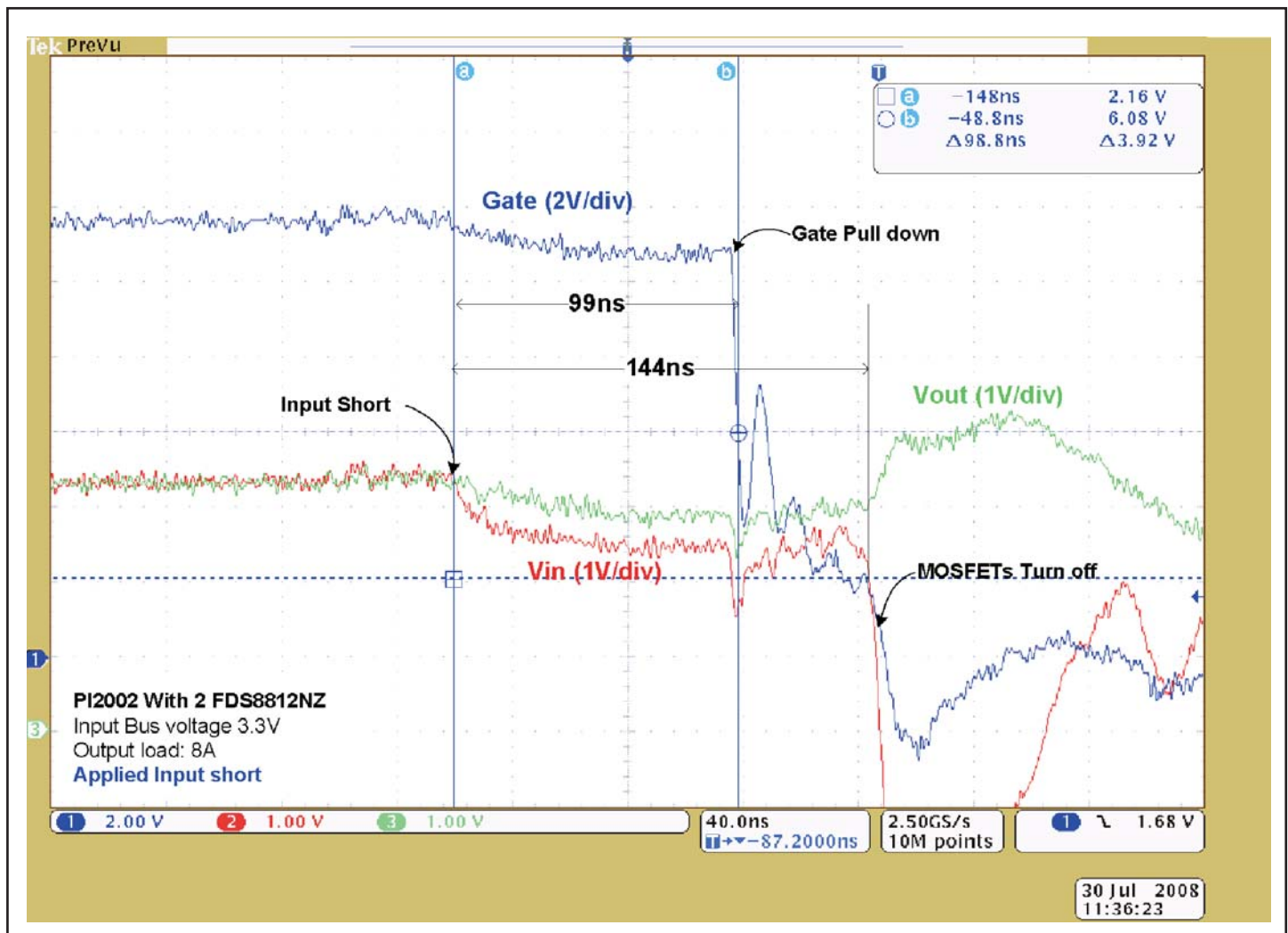

Figure 7 – Plot of PI2002 response time to reverse current detection

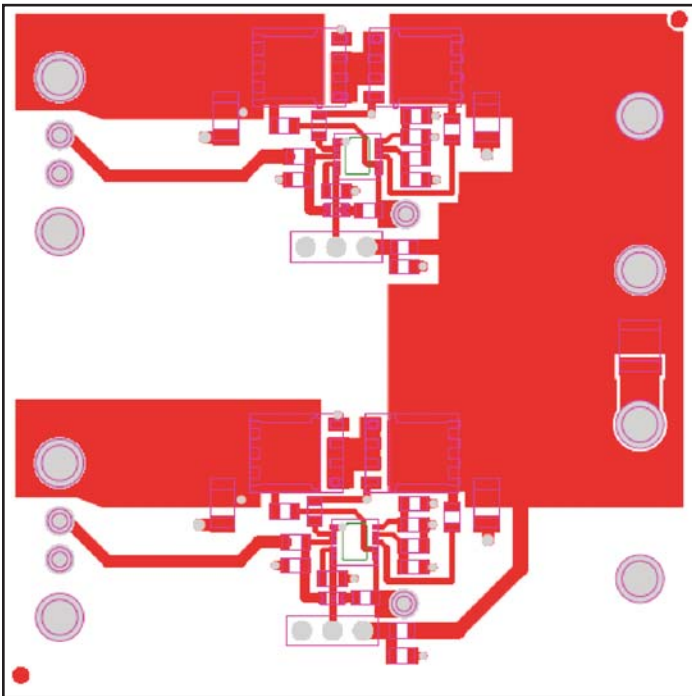

Figure 8a – PI2002-EVAL1 layout top layer. Scale 2.0:1

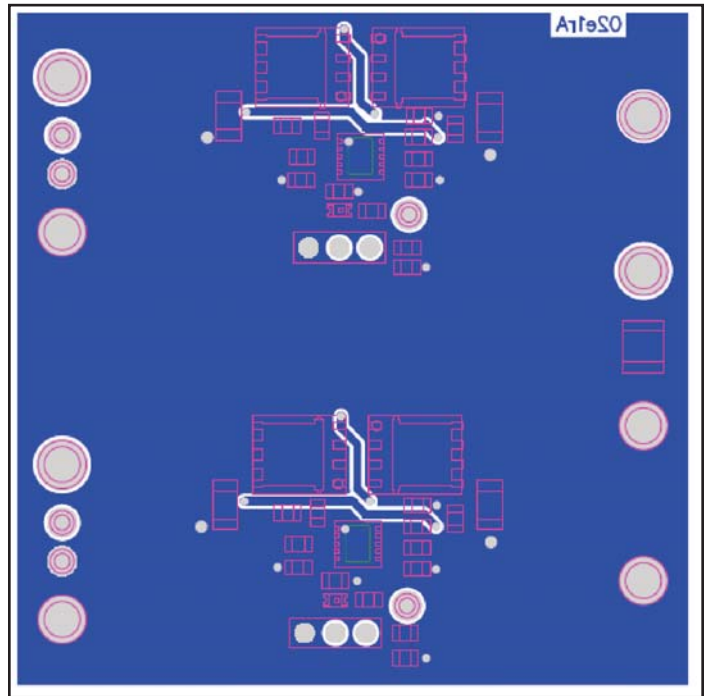
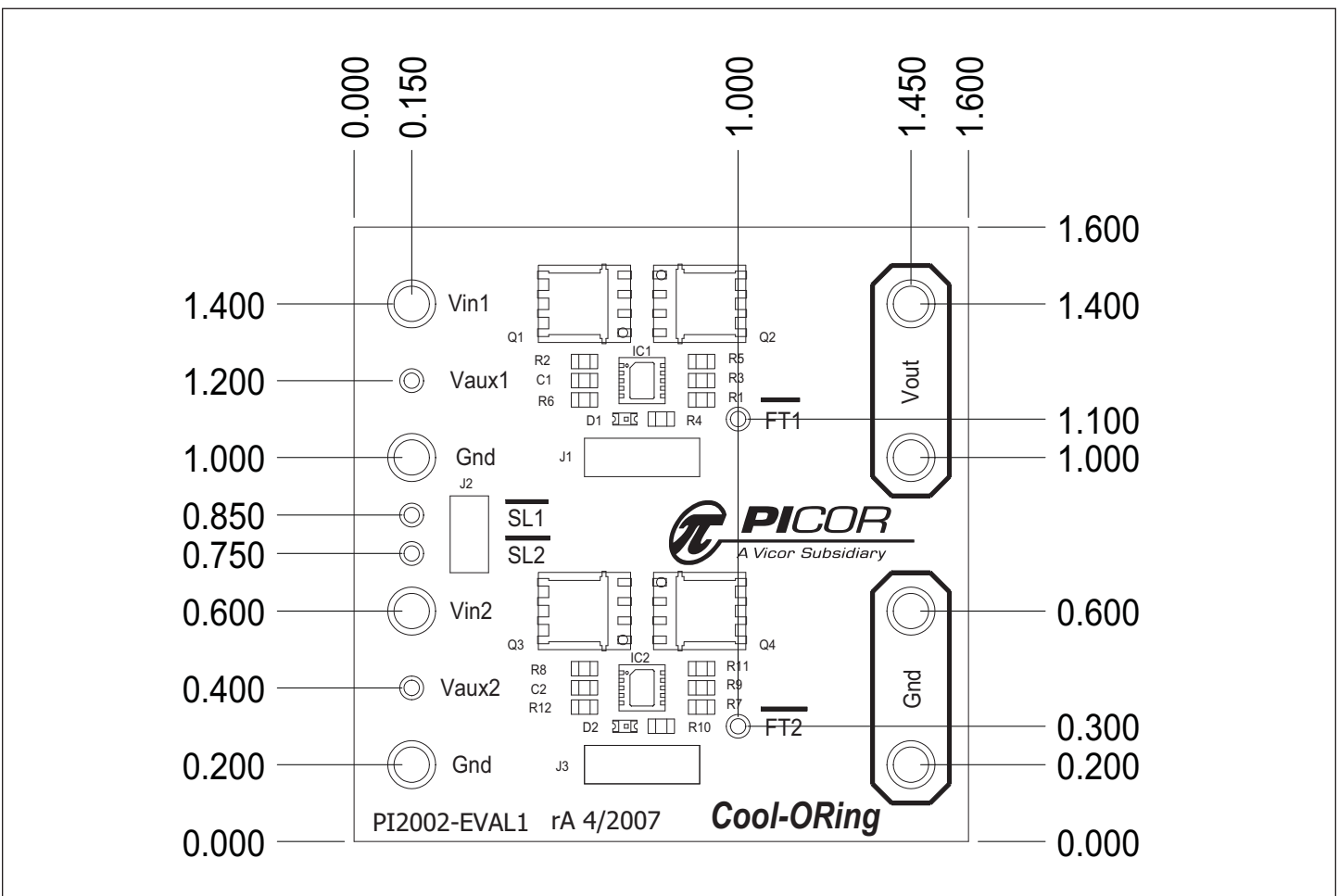

Figure 8b – PI2002-EVAL1 layout mid layer 2. Scale 2.0:1

Mechanical Drawing



Vicor's comprehensive line of power solutions includes high-density AC-DC & DC-DC modules and accessory components, fully configurable AC-DC & DC-DC power supplies, and complete custom power systems.

Information furnished by Vicor is believed to be accurate and reliable. However, no responsibility is assumed by Vicor for its use. No license is granted by implication or otherwise under any patent or patent rights of Vicor. Vicor components are not designed to be used in applications, such as life support systems, wherein a failure or malfunction could result in injury or death. All sales are subject to Vicor's Terms and Conditions of Sale, which are available upon request.

Specifications are subject to change without notice.



Vicor Corporation
25 Frontage Road
Andover, MA 01810
USA



Picor Corporation
51 Industrial Drive
North Smithfield, RI 02896
USA

Customer Service: custserv@vicorpower.com

Technical Support: apps@vicorpower.com

Tel: 800-735-6200

Fax: 978-475-6715