



Chipsmall Limited consists of a professional team with an average of over 10 year of expertise in the distribution of electronic components. Based in Hongkong, we have already established firm and mutual-benefit business relationships with customers from,Europe,America and south Asia,supplying obsolete and hard-to-find components to meet their specific needs.

With the principle of "Quality Parts,Customers Priority,Honest Operation,and Considerate Service",our business mainly focus on the distribution of electronic components. Line cards we deal with include Microchip,ALPS,ROHM,Xilinx,Pulse,ON,Everlight and Freescale. Main products comprise IC,Modules,Potentiometer,IC Socket,Relay,Connector.Our parts cover such applications as commercial,industrial, and automotives areas.

We are looking forward to setting up business relationship with you and hope to provide you with the best service and solution. Let us make a better world for our industry!



Contact us

Tel: +86-755-8981 8866 Fax: +86-755-8427 6832

Email & Skype: info@chipsmall.com Web: www.chipsmall.com

Address: A1208, Overseas Decoration Building, #122 Zhenhua RD., Futian, Shenzhen, China



PI2126-EVAL1 30V/12A Full-Function High Side Active ORing Evaluation Board User Guide

| Content | Page |
|----------------------------|------|
| Introduction | 1 |
| Product Description | 2 |
| Schematic. | 3 |
| Bill of Material | 3 |
| Test Procedure..... | 4 |
| Recommended Material | 4 |
| Thermal Imaging:..... | 6 |
| PCB Layout..... | 7 |
| Mechanical Drawing | 7 |



PI2126-EVAL1 Evaluation Board featuring the Cool-ORing PI2126 Full-Function Active ORing Solution.

The PI2126-EVAL1 Evaluation Board is intended to acquaint the user with the benefits and features of the Cool-ORing® PI2126 full-function Active ORing solution. It is not designed to be installed in end-use equipment.

Please read this document before setting up the PI2126-EVAL1 Evaluation Board and refer to the PI2126 product datasheet for device specifications, functional description and characteristics. During operation, the

power devices and surrounding structures can be operated safely at high temperatures.

Remove power and use caution when connecting and disconnecting test probes and interface lines to avoid inadvertent short circuits and contact with hot surfaces.

When testing electronic products always use approved safety glasses. Follow good laboratory practice and procedures.

Introduction

The PI2126-EVAL1 allows the user to test the basic principles and operational characteristics of an Active ORing function in a redundant power architecture, while also experiencing the benefits and value of the PI2126 solution versus conventional Active ORing solutions. The PI2126-EVAL1 evaluation board is configured to receive two independent power source inputs, per a typical redundant power architecture, through two Active ORing channels that are combined to form a redundant power output. Each channel is capable of up to 12A, and is suitable for 12V redundant bus voltages.

The PI2126-EVAL1 evaluation board is designed with optimized PCB layout and component placement to represent a realistic high density final design for an embedded Active ORing solution for 12V BUS applications

requiring up to 12A. This evaluation board is intended as an easy and simple way to test the electrical and thermal performance of the PI2126 Full-Function Active ORing solution.

Both dynamic and steady state testing of the PI2126 can be completed on the PI2126-EVAL1 evaluation board, in addition to using the key features of the product. Dynamic testing can be completed under a variety of system level fault conditions to check for response time to faults.

This document provides basic instructions for initial start-up and configuration of the evaluation board. Further information on the functionality of the PI2126 can be found in the PI2126 product datasheet.

Cool-ORing® PI2126 Product Description

The PI2126 *Cool-ORing*® is a complete full-function Active ORing solution with a high-speed ORing MOSFET controller and a very low on-state resistance MOSFET designed for use in redundant power system architectures. The PI2126 *Cool-ORing*® solution is offered in an extremely small, thermally enhanced 5mm x 7mm LGA package and can be used in high side, medium voltage Active ORing applications. The PI2126 enables extremely low power loss with fast dynamic response to fault conditions, critical for high availability systems.

The PI2126, with its 30V/5.5mΩ internal MOSFET provides very high efficiency and low power loss during steady state operation, while achieving high-speed turn-off of the internal MOSFET during input power source fault conditions that cause reverse current flow. The PI2126 provides an active low fault flag output to the system during reverse current, excessive forward over-current and UVLO fault conditions.

Figure 1 shows a photo of the PI2126-EVAL1 evaluation board, with two PI2126 SiPs used to form the two Active ORing channels. The board is built with two identical Active ORing circuits with options and features that enable the user to fully explore the capabilities of the PI2126 *Cool-ORing*® solution.



Figure 1: PI2126-EVAL1 Evaluation Board (1.8" x 1.8")

Terminals Maximum Rating.

| | |
|-------------------------------------|------------|
| Vin1+, Vin2+, | 15V/12A |
| Vout+ | 15V/24A |
| $\overline{FT1}$, $\overline{FT2}$ | 20V / 10mA |

| Terminal | Description |
|---|--|
| Vin1+ | Power source Input #1: or bus input designed to accommodate up to 15V and 12A continuous current. |
| Vin2+ | Power source Input #2: or bus input designed to accommodate up to 15V and 12A continuous current. |
| $\overline{FT1}$ | PI2126 (U1) Fault pin: referenced to the Gnd terminal (Gnd) |
| $\overline{FT2}$ | PI2126 (U2) Fault pin: referenced to the Gnd terminal (Gnd) |
| Vout | Output: U1 and U2 D pins connection, connect to the load high side. |
| S1 and D1 | U1 Source to Drain Kelvin test points |
| S2 and D2 | U2 Source to Drain Kelvin test points |
| Gnd | Return Connection: Four Gnd connections are available and are connected to a common point, the Ground plane. Input supplies Vin1, Vin2, and the output load at Vout should all be connected to their respective local Rtn connection. |
| Note: Gnd, Gnd and Gnd are connected to the same point at the PCB bottom layer | |

Table 1: PI2126-EVAL1 Evaluation Board Terminals Description

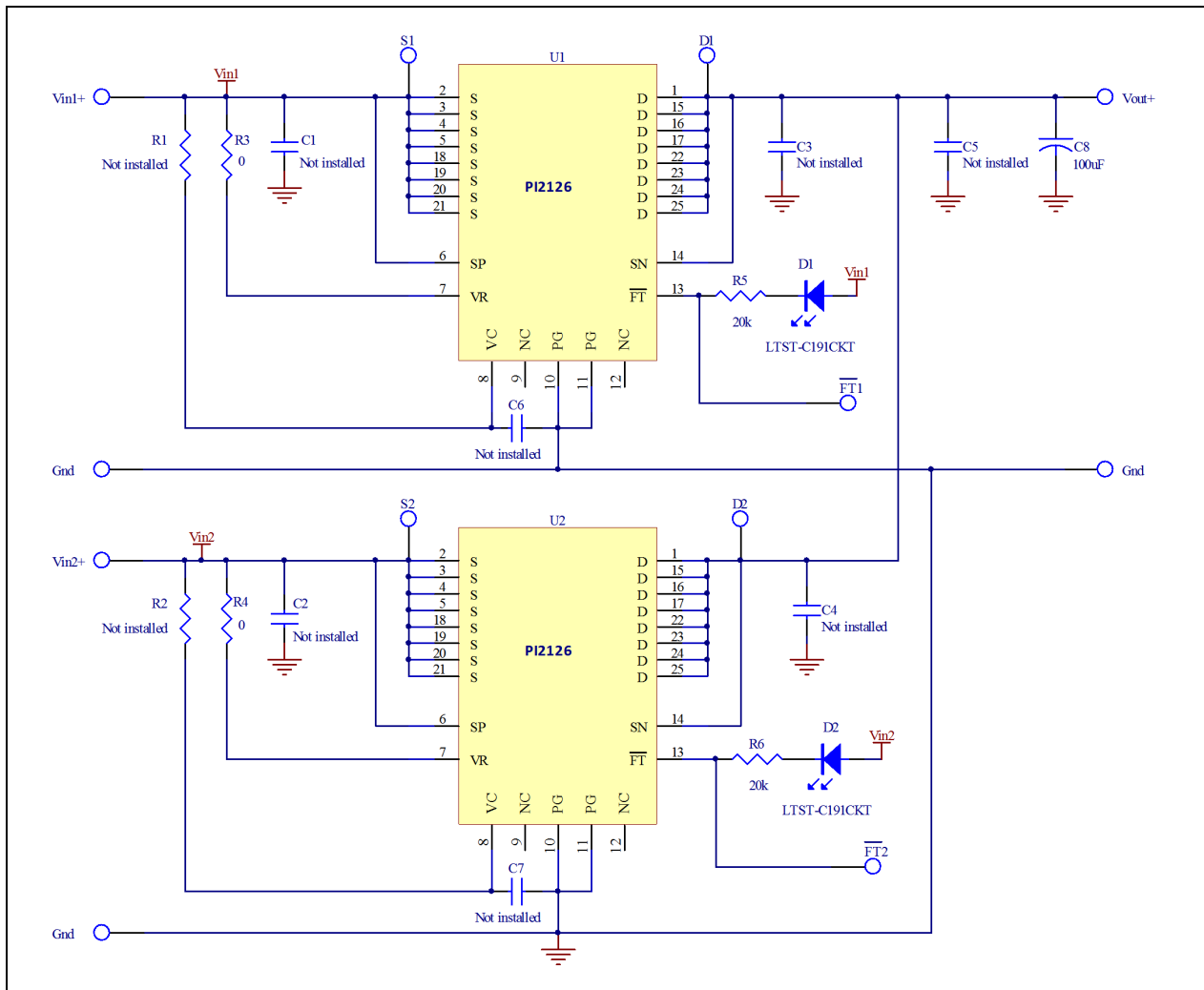

Figure 2: PI2126-EVAL1 Evaluation Board schematic.

| Item | Qty | Reference Designator | Value | Description | Footprint | Manufacturer |
|------|-----|--|----------------|--|------------------|----------------------|
| 1 | 4 | C1, C2, C3, C4 | Not Installed | MLCC, X7R,1uF,50V | 1206 | |
| 2 | 1 | C5 | 100uF | Electrolytic 100uF, 63V | Panasonic _E/F | Panasonic |
| 3 | 1 | C6 | Not Installed | MLCC 1uF, 25V | 0603 | |
| 4 | 2 | D1, D2 | LTST-C191CKT | LED, Red | 0603 LED | Lite-On |
| 5 | 6 | FT1, FT2, S1, S2, D1, D2 | 1528 | Turret Test point | TURRET - 1528 | Keystone Electronics |
| 6 | 8 | Vin1+, Vin2+, Vout, Vout, Gnd, Gnd, Gnd, Gnd | 1502 | Turret Test point | TURRET - 1502 | Keystone Electronics |
| 7 | 2 | R1, R2 | Not Installed | | 1206 | |
| 8 | 2 | R3, R4 | 0Ω | Resistor, 0Ω | 0603 | |
| 9 | 2 | R5, R6 | 20kΩ | Resistor, 1.5K, 1% | 0603 | |
| 10 | 1 | U1, U2 | PI2126-00-LGIZ | 12A 30V Full-Function Cool-ORing® Solution | 5mm x 7mm 25 pin | PICOR |

Table 2: Complete PI2126-EVAL1 Evaluation Board Bill of Material

| Reference Designator | Value | Functional Description |
|----------------------|----------------|---|
| C1, C2, C3, C4 | Not installed | Snubber to reduce voltage ringing when the device turns off |
| C3 | 22 μ F | Output (Load) Capacitor |
| C6 | 2.2 μ F | Output (Load) Capacitor |
| D1, D2 | LED | To indicate a fault exists when it is on |
| R1, R2 | Not Installed | Bias resistor optional, can be used to replace the internal resistor. Remove R3, and R4 if the this option is desired. |
| R3, R4 | 0 Ω | Controller bias input through internal resistor. |
| R5, R6, | 20K Ω | LED current limit resistor, selected to operate at 3.3V and 5.0V logic voltage. Replace R5 and R6 with the proper resistor value for different logic voltage. |
| U1, U2 | PI2126-01-LGIZ | Cool-ORing [®] SIP. |

Table 3: Component functional description

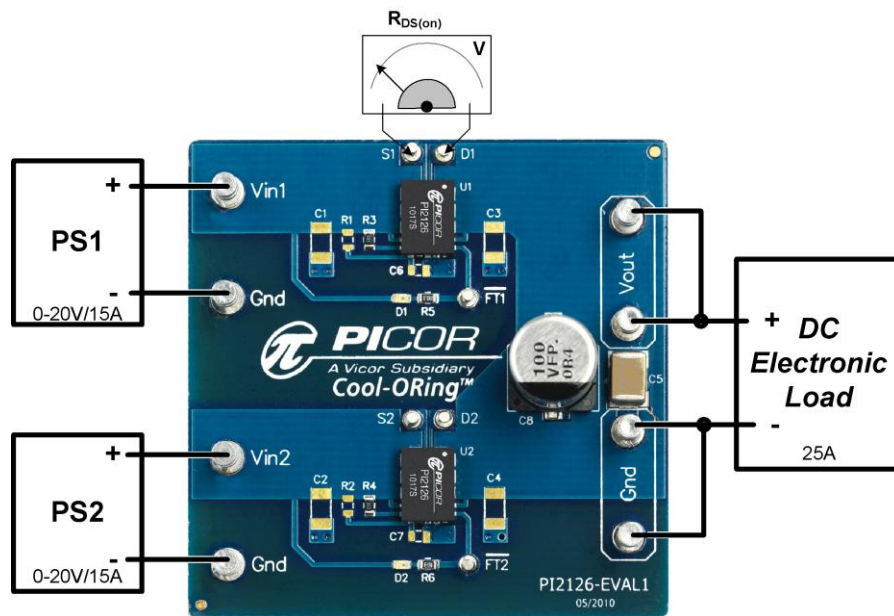

Figure 3: Layout configuration for typical redundant power application, using PI2126-01-LGIZ

Test Procedure:

Initial Test Set Up

PI2126-EVAL1 designed with two input bias configurations, VC biased via external resistors (R1 and R2) or VC biased via the internal resistor (VR input pin, $R_{Bias}=420\Omega \pm 30\%$). PI2126-EVAL1 is configured with the internal bias resistors, R3 and R4 are installed where R1 and R2 were not installed. If external VC bias resistor with higher accuracy is desired, remove R3 and R4 before installing R1 and R2.

Baseline Test Procedure – PI2126 (Refer to Figure 3)

1. Recommended Material

1.1. Material Needed-Picor supplied

- 1.1.1. PI2126-EVAL1
- 1.1.2. PI2126 Product Datasheet

1.2. Recommended Users Supplied Equipment

- 1.2.1. Two DC power supplies: 0-20V; 15A each.
- 1.2.2. One low power logic voltage power supply
- 1.2.3. Load: electronic Load, Power resistors or actual load.
- 1.2.4. Multimeter.
- 1.2.5. Oscilloscope.
- 1.2.6. Appropriately sized interconnect cables.
- 1.2.7. Safety glasses.

Before initial power-up follow these steps to configure the evaluation board for specific end application requirements:

2. Hook Up of the Evaluation Board

- 2.1. Connect the positive terminal of PS1 power supply to Vin1+. Connect the ground terminal of PS1 to Gnd. Set the power supply to 12V. **Keep PS1 output disabled, off.**
- 2.2. Connect the positive terminal of PS2 power supply to Vin2+. Connect the ground terminal of PS2 to Gnd. Set the power supply to 12V. **Keep PS2 output disabled, off.**
- 2.3. Connect the electronic load to the output between Vout and Gnd. Set the load current to 5A.
- 2.4. Enable (turn on) PS1 power supply output.
- 2.5. Turn on the electronic load.
- 2.6. Verify that Vout+ voltage is a few millivolts below 12V. This verifies that the PI2126 (U1) internal MOSFET is in conduction mode.
- 2.7. Verify that Vin2+ is low. This verifies that the PI2126 (U2) internal MOSFET is off.
- 2.8. Enable (turn on) PS2 output.
- 2.9. Verify that both PS1 and PS2 are sharing load current evenly by looking at the supply current. *Power supplies output may need adjustment to set current sharing between the supplies.*
- 2.10. Disable (turn off) PS1, and PS2 outputs.
- 2.11. Enable (turn on) PS2 output.
- 2.12. Verify that the electronic load voltage reading is few millivolts below 12V. This verifies that the PI2126 (U2) internal MOSFET is in conduction mode.
- 2.13. D2 should be off. This verifies that there is no fault condition.
- 2.14. Verify that Vin1+ is low. This verifies that the PI2126 (U1) internal FET is off.

Note: When the PI2126 internal MOSFET is in the on state, it will not turn off unless a reverse current greater than 1.1A is sensed in the MOSFET.

When both power supplies are enabled and both PI2126 MOSFETs are in $R_{DS(on)}$, if one of the sources (Power supplies) removed or disabled both PI2126 stay on unless the disabled power supply sources current greater than 1.1A when turned off.

3. Internal MOSFET $R_{DS(on)}$ Measurement:

- 3.1. The internal MOSFET $R_{DS(on)}$ can be measured with a voltmeter between the S1 and D1 Kelvin connection for U1 and between the S2 and D2

Kelvin connection for U2. The potential between S1 and D1 is the voltage drop across the internal MOSFET and:

$$R_{DS(on)} = \frac{V_{S1} - V_{D1}}{I_{in}}$$

Where:

$V_{S1} - V_{D1}$: Voltage drop across the internal MOSFET
 I_{in} : Input current.

Note: The $R_{DS(on)}$ value is temperature dependent and the junction temperature increases directly proportional to power dissipation.

4. Input short circuit test:

PI2126 has a very fast response (80ns) to a reverse current (Input short) fault condition. Measuring a short period event requires attention to the test set-up. Before proceeding, consider the following:

- 4.1. To emulate a real application, the BUS supplies for this test should have a solid output source such as a DC-DC converter that supplies high current and can be connected very close to the evaluation board to reduce stray parasitic inductance. Or use the prospective supply sources of the end application where the PI2126 will be used. Typical bench power supplies have slow response to output load change. In this test when the power supply output is shorted and then released, the bench power supply may produce high output voltage with high current capability that may damage the device under test.
- 4.2. Do not install Input capacitors (C1 and/or C2) in this test.
- 4.3. Output capacitor (C5) should be installed.
- 4.4. Place the scope probes very close to the PI2126 S and D pins to measure Vin and Vout, and make sure that the scope ground leads are very short. You may use a close by ground pad for the scope probe return, such as C1, C2, C3 and C4 return pads.
- 4.5. Apply a short at one of the inputs (Vin1+ or Vin2+) when both SiP's (U1 and U2) are on, PS1 and PS2 are enabled. The short can be applied electronically using a MOSFET connected between Vin+ and Gnd or simply by connecting Vin+ to Gnd. Then measure the response time between when the short is applied and the PI2126 internal MOSFET is disconnected (or turned off). An example for the PI2126 response time to an input short circuit is shown in Figure 4.

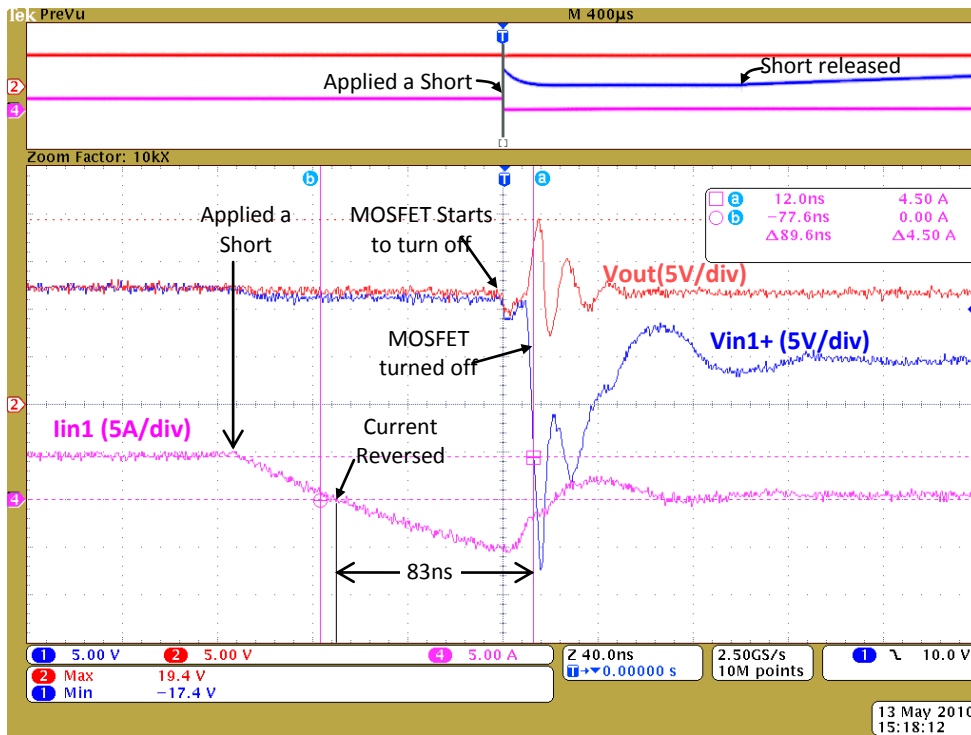

Test Setup:
DUT: PI2126-EVAL1
Vin1+ = 12V
Vin2+ = 12V
Output Load = 12A

Test:
 Both input sources are turned on and sharing the load current, then applied a short between Vin1+ and Gnd for 1ms.

Test purpose:
 To show the PI2126 response to a fault condition, where the output of the input source is shorted or tried to source current from the load (Vout).

Figure 4: Plot of PI2126 response time to reverse current detection

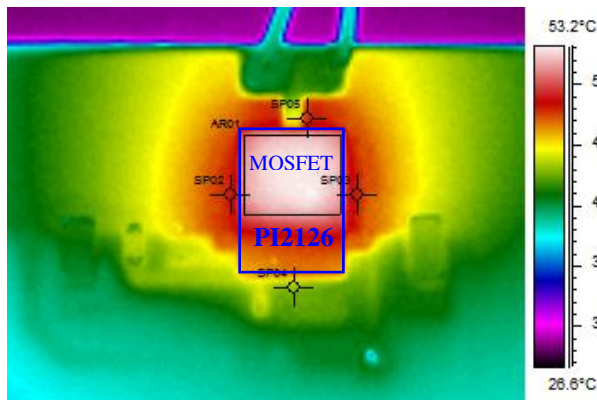

Figure 5: PI2126 mounted on PI2126-EVAL1, Iout=12A, TA=25°C, Air Flow=0LFM

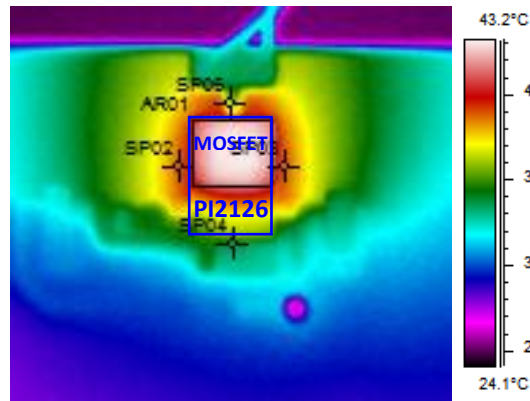

Figure 6: PI2126 mounted on PI2126-EVAL1, Iout=12A, TA=25°C, Air Flow=200LFM

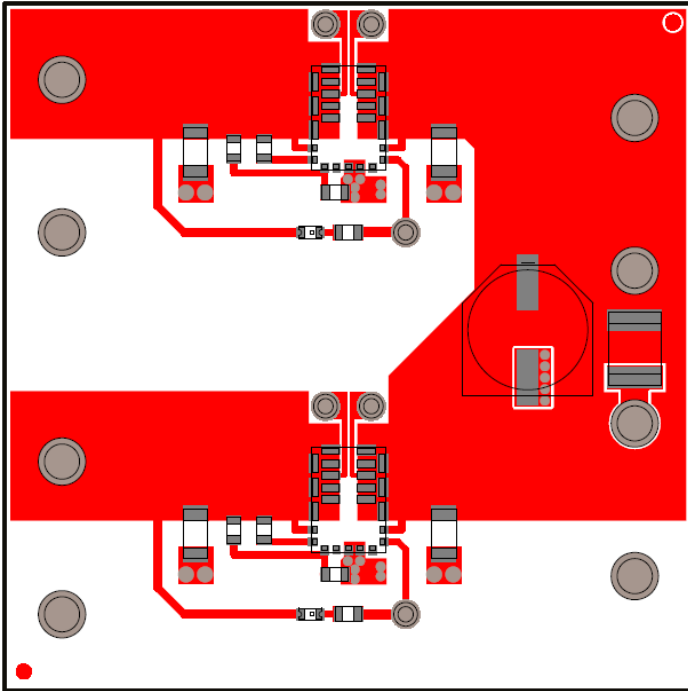

Figure 7: PI2126-EVAL1 layout top layer. Scale 2.0:1

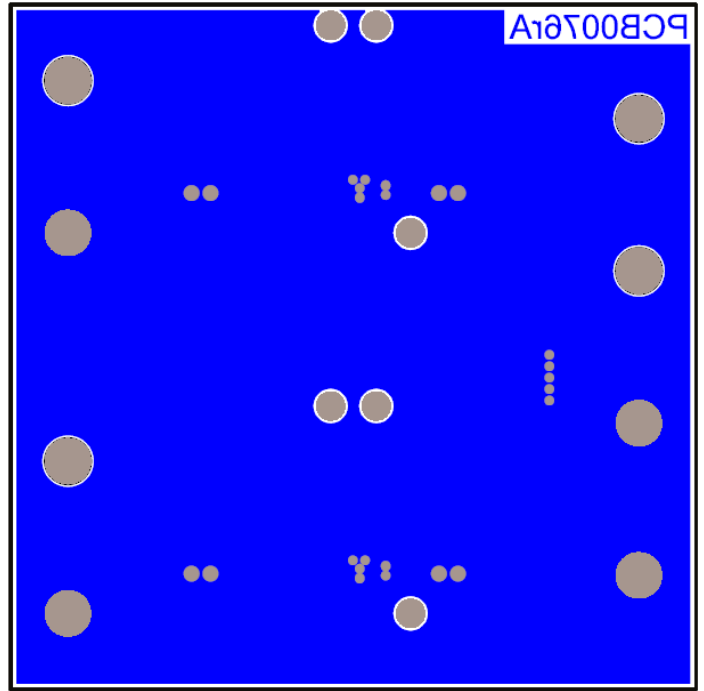

Figure 8: PI2126-EVAL1 layout bottom layer 2. Scale 2.0:1

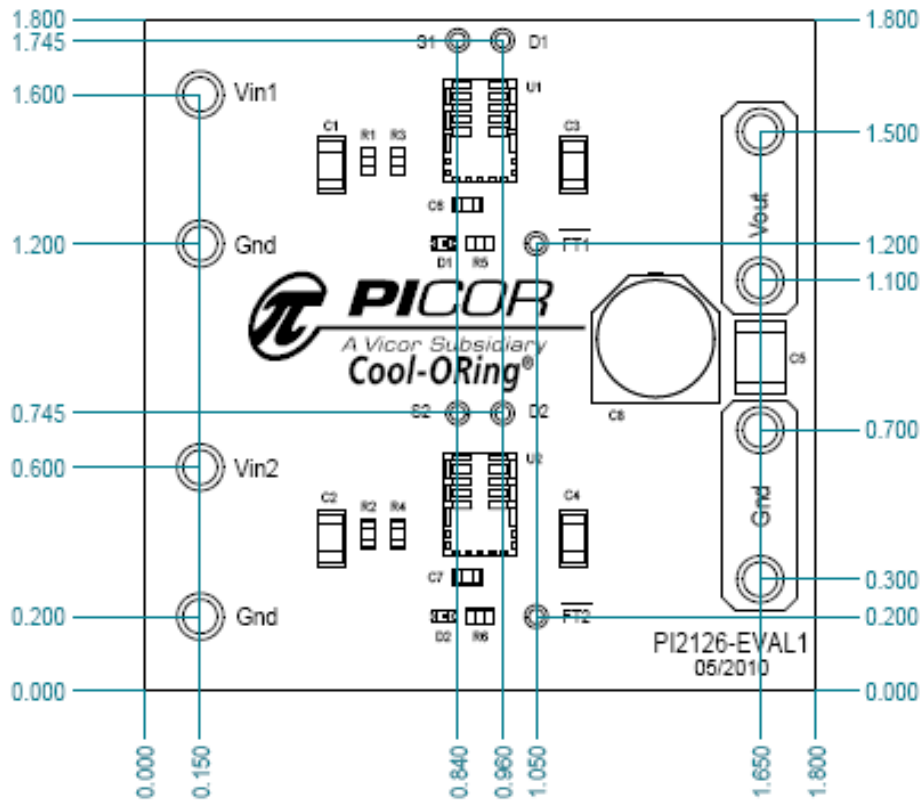

Figure 9: PI2126-EVAL1 evaluation board mechanical drawing.

Warranty

Vicor products are guaranteed for two years from date of shipment against defects in material or workmanship when in normal use and service. This warranty does not extend to products subjected to misuse, accident, or improper application or maintenance. Vicor shall not be liable for collateral or consequential damage. This warranty is extended to the original purchaser only.

EXCEPT FOR THE FOREGOING EXPRESS WARRANTY, VICOR MAKES NO WARRANTY, EXPRESS OR LIMITED, INCLUDING, BUT NOT LIMITED TO, THE WARRANTY OF MERCHANTABILITY OR FITNESS FOR A PARTICULAR PURPOSE.

Vicor will repair or replace defective products in accordance with its own best judgment. For service under this warranty, the buyer must contact Vicor to obtain a Return Material Authorization (RMA) number and shipping instructions. Products returned without prior authorization will be returned to the buyer. The buyer will pay all charges incurred in returning the product to the factory. Vicor will pay all reshipment charges if the product was defective within the terms of this warranty.

Information published by Vicor has been carefully checked and is believed to be accurate; however, no responsibility is assumed for inaccuracies. Vicor reserves the right to make changes to any products without further notice to improve reliability, function, or design. Vicor does not assume any liability arising out of the application or use of any product or circuit; neither does it convey any license under its patent rights nor the rights of others. Vicor general policy does not recommend the use of its components in life support applications wherein a failure or malfunction may directly threaten life or injury. Per Vicor Terms and Conditions of Sale, the user of Vicor components in life support applications assumes all risks of such use and indemnifies Vicor against all damages.

Vicor's comprehensive line of power solutions includes high density AC-DC and DC-DC modules and accessory components, fully configurable AC-DC and DC-DC power supplies, and complete custom power systems.

Information furnished by Vicor is believed to be accurate and reliable. However, no responsibility is assumed by Vicor for its use. Vicor components are not designed to be used in applications, such as life support systems, wherein a failure or malfunction could result in injury or death. All sales are subject to Vicor's Terms and Conditions of Sale, which are available upon request.

Specifications are subject to change without notice.

Vicor Corporation
25 Frontage Road
Andover, MA 01810
USA

Picor Corporation
51 Industrial Drive
North Smithfield, RI 02896
USA

Customer Service: custserv@vicorpower.com

Technical Support: apps@vicorpower.com

Tel: 800-735-6200

Fax: 978-475-6715