



Chipsmall Limited consists of a professional team with an average of over 10 year of expertise in the distribution of electronic components. Based in Hongkong, we have already established firm and mutual-benefit business relationships with customers from,Europe,America and south Asia,supplying obsolete and hard-to-find components to meet their specific needs.

With the principle of "Quality Parts,Customers Priority,Honest Operation,and Considerate Service",our business mainly focus on the distribution of electronic components. Line cards we deal with include Microchip,ALPS,ROHM,Xilinx,Pulse,ON,Everlight and Freescale. Main products comprise IC,Modules,Potentiometer,IC Socket,Relay,Connector.Our parts cover such applications as commercial,industrial, and automotives areas.

We are looking forward to setting up business relationship with you and hope to provide you with the best service and solution. Let us make a better world for our industry!



## Contact us

Tel: +86-755-8981 8866 Fax: +86-755-8427 6832

Email & Skype: info@chipsmall.com Web: www.chipsmall.com

Address: A1208, Overseas Decoration Building, #122 Zhenhua RD., Futian, Shenzhen, China



# PI2211-EVAL1: 12V/10A Cool-Swap™ Controller Evaluation Board User Guide

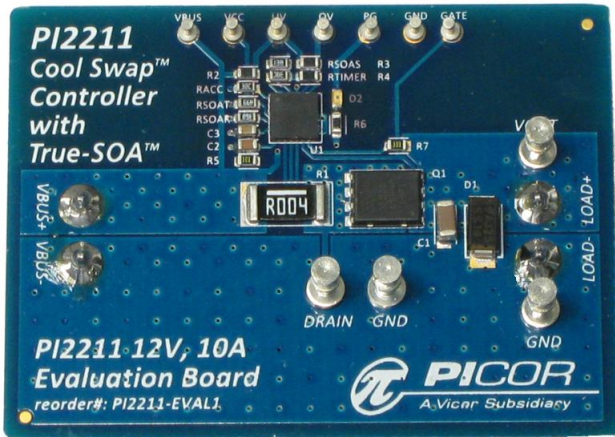

**Figure 1 - PI2211 EVAL1 Evaluation Board**

The PI2211 EVAL1 evaluation board is designed to acquaint the user to the features and benefits of Picor's PI2211 Cool-Swap™ controller; featuring True-SOA™ MOSFET power monitoring and protection, and Glitch-Catcher™ voltage suppression circuitry. The PI2211 EVAL1 board is designed for a 12V nominal BUS voltage, with an operational BUS range of 11V to 13V. It is designed to be run at 10A continuously with a circuit breaker threshold of 13A and a start-up current limit of 6.25A.

The evaluation board features screw-type terminal blocks to allow for easy connections to a supply and a load. Key signal nodes are brought out to turret pins; such as power-good, under-voltage/enable and over-voltage. These pins can be used for monitoring or for connection to external control circuitry.

The PI2211 EVAL1 evaluation board is not designed, nor is it intended, to be used as a component in an end-product. Please refer to the PI2211 datasheet for detailed functional descriptions, characteristics and specifications.

### Evaluation Board Test Points

Test Point	Description
GATE	GATE drive signal of the PI2211
OV	Over-Voltage pin.
UV	Under-Voltage and Enable pin.
PG	Power-good signal pin.
DRAIN	MOSFET Drain signal.
VBUS	Input BUS signal.
VCC	PI2211's VCC pin.
GND	GND reference for all signal measurements.

**Table 1 - Evaluation Board Test Points**

### Evaluation Board Supply and Load Connections

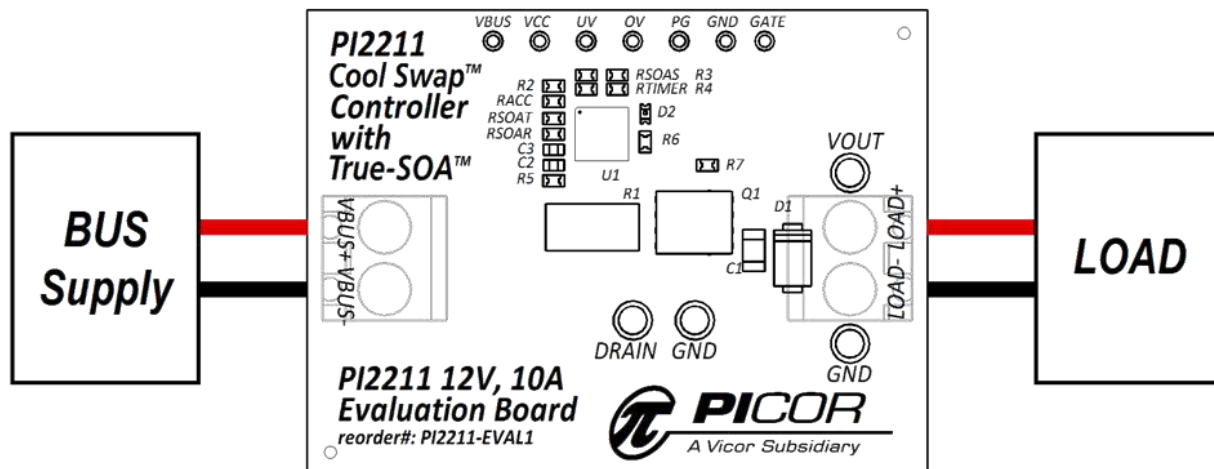

**Figure 2 - Evaluation board connections.**

### PI2211 Evaluation Board Schematic

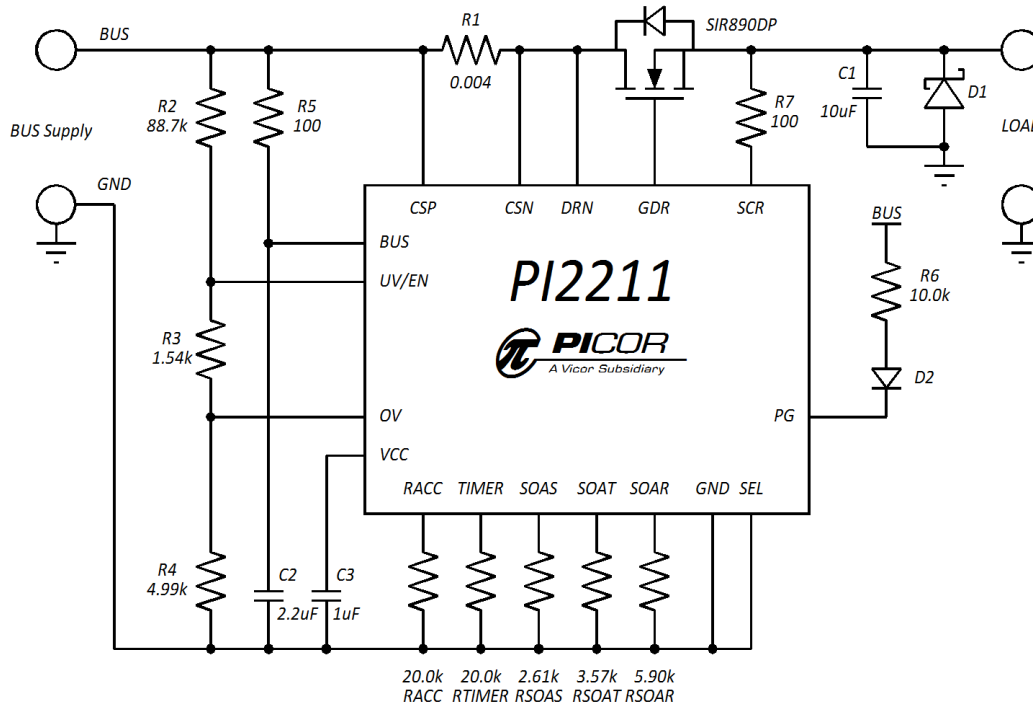

Figure 3 - Final Design Schematic

### PI2211 Evaluation Board BOM

Quantity	Designator	Manufacturer	Manufacturer Part No.	Value	Description
1	U1	Picor	PI2211-00-QAIG	PI2211	PI2211 Hot-Swap Controller
1	C1	Murata	GRM31CR61C106C31L	10uF	Ceramic Capacitor, 16V
1	C2	TDK	C1608X5R1E225K	2.2uF	Ceramic Capacitor, 25V
1	C3	Murata	GRM188R61C105KA93D	1uF	Ceramic Capacitor, 16V
1	D1	Fairchild	SS14	SS14	40V, 1A Schottky Diode
1	D2	Lite-On Inc.	LTST-C191KRKT		0603 Red LED
1	Q1	Vishay	SIR890DP	SIR890DP	N- MOSFET
2	R5, R7	Rohm	MCR03EZPFX1000	100	Resistor, 0603
1	R6	Rohm	MCR03EZPFX1002	10.0K	Resistor, 0603
2	RACC, RTIMER	Rohm	MCR03EZPFX2002	20.0K	RACC, RTIMER Resistor, 0603
1	R2	Rohm	MCR03EZPFX8872	88.7K	RHIGH Resistor, 0603
1	R3	Rohm	MCR03EZPFX1541	1.54K	RMID Resistor, 0603
1	R4	Rohm	MCR03EZPFX4991	4.99K	RLOW Resistor, 0603
1	R1	Yageo	PR2512FKF070R004L	0.004	1W Current Sense Resistor
1	RSOAR	Rohm	MCR03EZPFX5901	5.90k	RSOAR Resistor, 0603
1	RSOAS	Rohm	MCR03EZPFX2611	2.61k	RSOAS Resistor, 0603
1	RSOAT	Rohm	MCR03EZPFX3571	3.57k	RSOAT Resistor, 0603
2	BUS, LOAD	Weidmuller	171602		2 Contact Terminal Block
7	GATE, GND, OV, PG, UV, VBUS, VCC	Keystone	1528		Generic Testpoint

Table 2 - PI2211 Evaluation board Bill of Materials

**PI2211 Evaluation Board Waveforms**

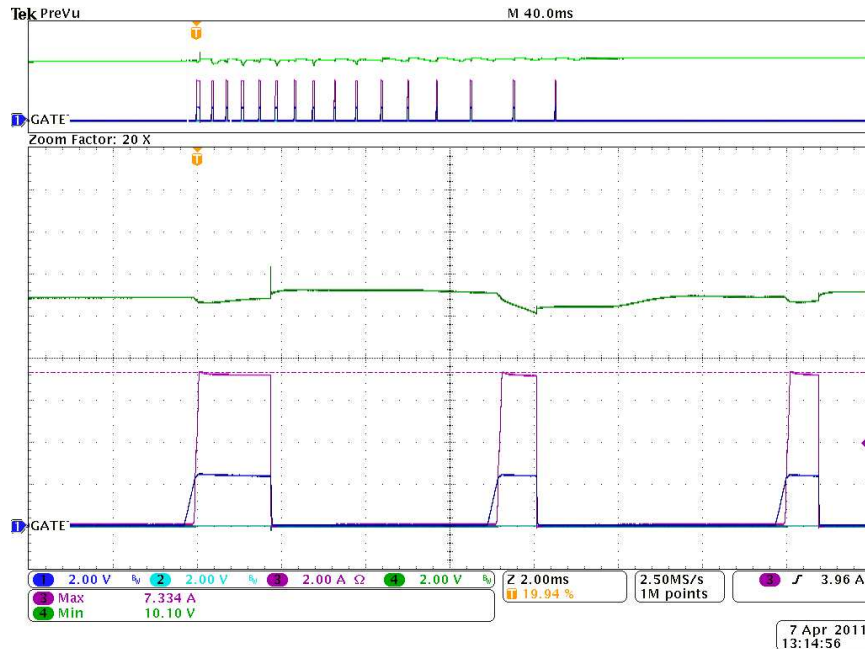

**Figure 4 - SOA Thermal Cycling**  
Ch1)  $V_{GATE}$  Ch2) Power Good Ch3)  $I_{BUS}$  Ch4)  $V_{DRAIN}$

The waveforms in Figure 4 show the performance of the SOA thermal cycling with a shorted output on the evaluation board. The first pulse represents a predicted 60°C junction temperature rise before ending. The second pulse starts once the predicted junction temperature rise has dropped to 29°C. The width of the second pulse to the 16th pulse represent a junction temperature rise of 31°C (29°C to 60°C).

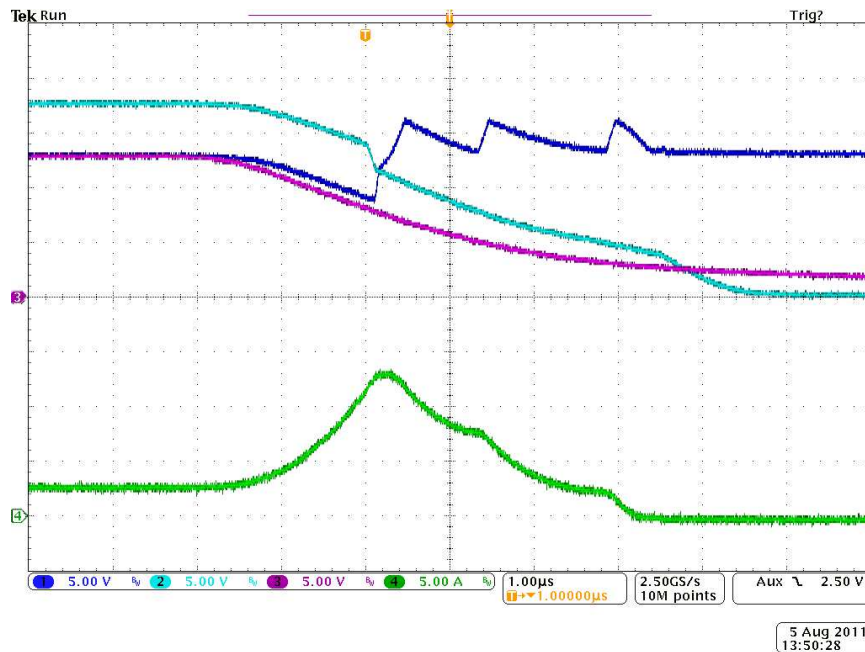

**Figure 5 - Glitch-Catcher™ Circuit Breaker Turn-off.**  
Ch1)  $V_{DRAIN}$  Ch2)  $V_{GATE}$  Ch3)  $V_{SOURCE}$  Ch4)  $I_{BUS}$

Figure 5 shows the response of the Glitch-Catcher™ to a shorted output. The drain voltage (Ch1, blue) and the gate voltage (Ch2, cyan) both droop as the current increases through the MOSFET. Once the circuit breaker current threshold has been passed (Ch4, green), the gate gets discharged quickly until the drain voltage starts to rise. The rate of the gate's discharge is reduced to reduce the voltage rate of change on the drain. The discharge of the gate is controlled, toggling between a high a low discharge rate, to maintain the drain voltage over-shoot to be within the 15V limit.

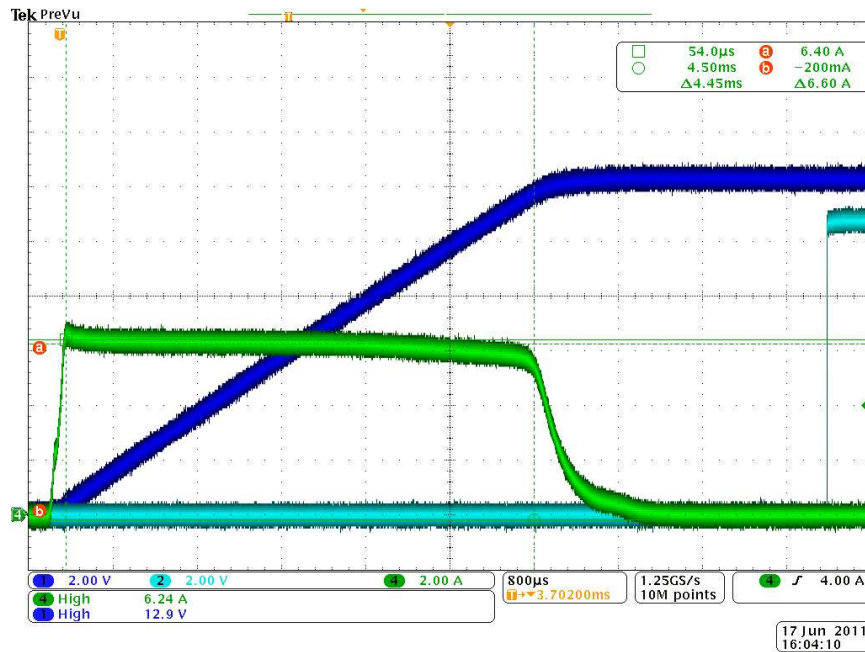

**Figure 6 - Start-up with 6 x 470uF of load capacitance.**  
 Ch1) V<sub>SOURCE</sub> Ch2) Power Good Ch4) I<sub>BUS</sub>

Figure 6 demonstrates the ability of the PI2211 to start-up a large amount of load capacitance. Here, there are 6, 470uF capacitors on the output of the demo board, a 12V BUS voltage and a start-up current limit of 6.25A. As the capacitors charge the voltage drop across the MOSFET decreases, decreasing the power across the MOSFET. Because the PI2211 monitors power, it will allow the MOSFET to remain on longer, calculating that the temperature increase has lessened due to the drop in power across the MOSFET. This increases the amount of load capacitance that the PI2211 can start-up with.

PCB Layout

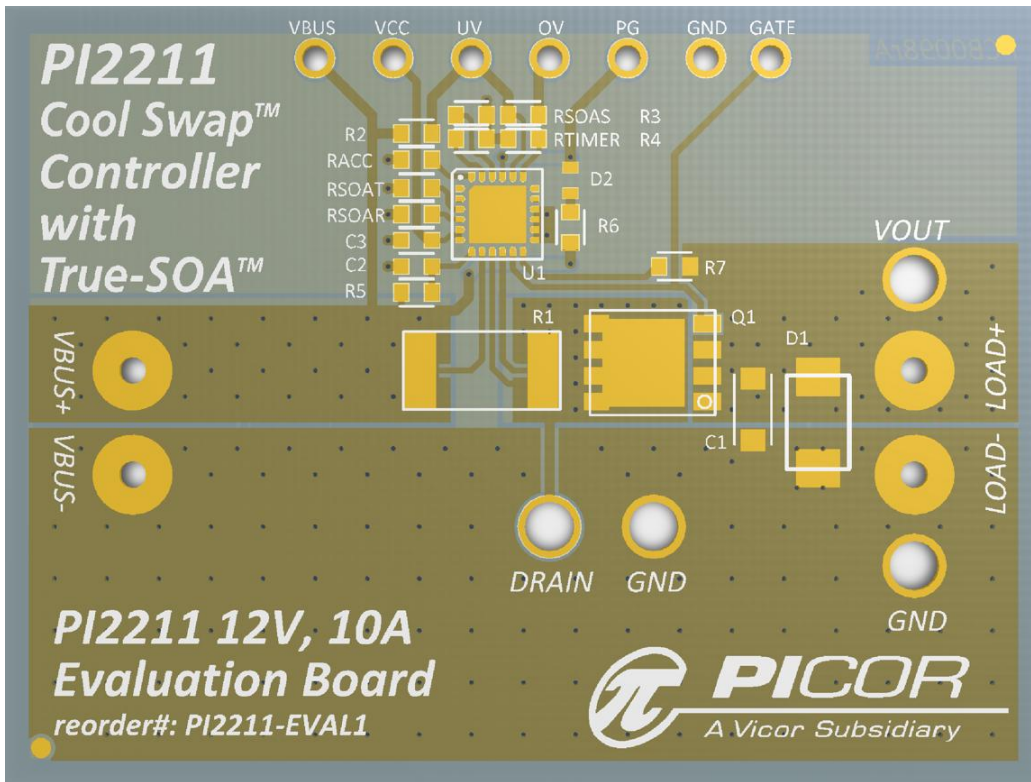

Figure 7 - Top Layer

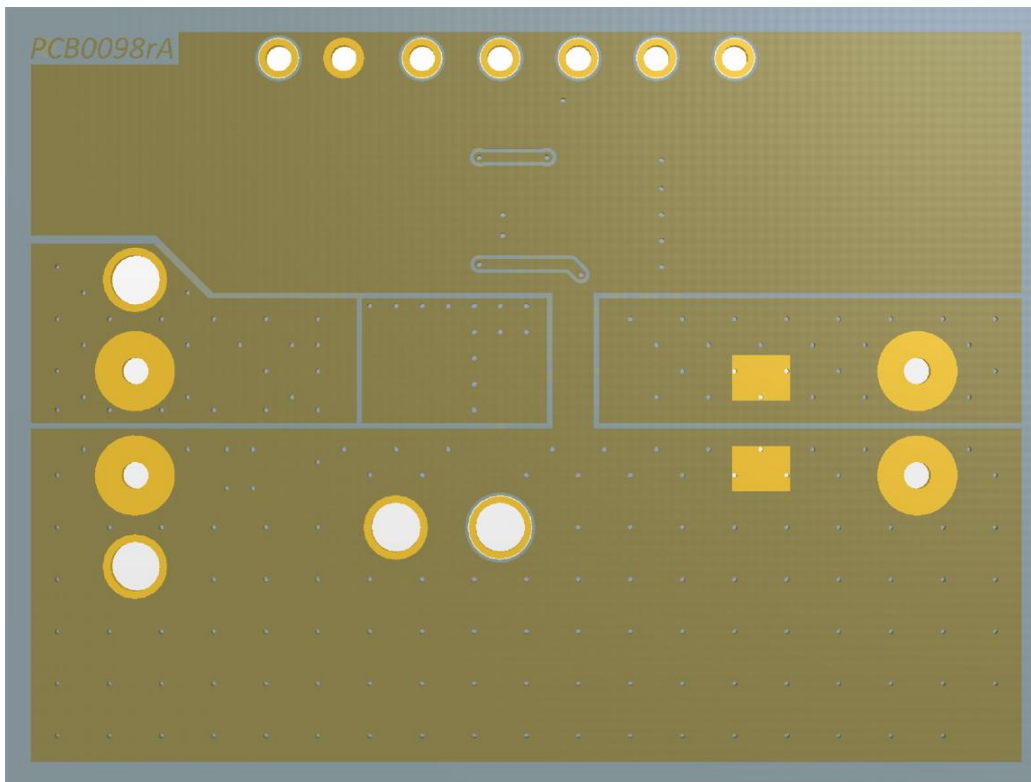

Figure 8 - Bottom Layer

PCB Mechanicals

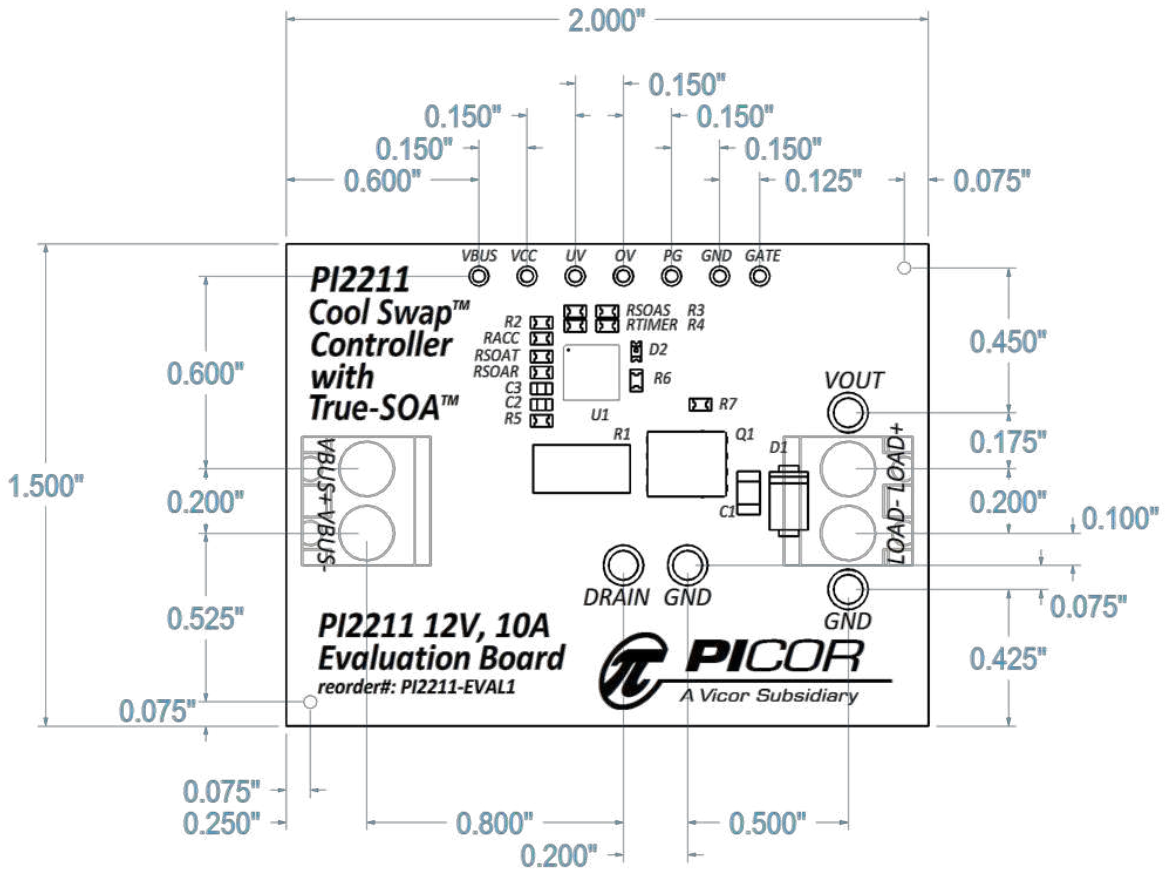

Figure 9 - PI2211 EVAL1 Board Dimensions

## Warranty

Vicor products are guaranteed for two years from date of shipment against defects in material or workmanship when in normal use and service. This warranty does not extend to products subjected to misuse, accident, or improper application or maintenance. Vicor shall not be liable for collateral or consequential damage. This warranty is extended to the original purchaser only.

EXCEPT FOR THE FOREGOING EXPRESS WARRANTY, VICOR MAKES NO WARRANTY, EXPRESS OR LIMITED, INCLUDING, BUT NOT LIMITED TO, THE WARRANTY OF MERCHANTABILITY OR FITNESS FOR A PARTICULAR PURPOSE.

Vicor will repair or replace defective products in accordance with its own best judgment. For service under this warranty, the buyer must contact Vicor to obtain a Return Material Authorization (RMA) number and shipping instructions. Products returned without prior authorization will be returned to the buyer. The buyer will pay all charges incurred in returning the product to the factory. Vicor will pay all reshipment charges if the product was defective within the terms of this warranty.

Information published by Vicor has been carefully checked and is believed to be accurate; however, no responsibility is assumed for inaccuracies. Vicor reserves the right to make changes to any products without further notice to improve reliability, function, or design. Vicor does not assume any liability arising out of the application or use of any product or circuit; neither does it convey any license under its patent rights nor the rights of others. Vicor general policy does not recommend the use of its components in life support applications wherein a failure or malfunction may directly threaten life or injury. Per Vicor Terms and Conditions of Sale, the user of Vicor components in life support applications assumes all risks of such use and indemnifies Vicor against all damages.

**Vicor's comprehensive line of power solutions includes high density AC-DC and DC-DC modules and accessory components, fully configurable AC-DC and DC-DC power supplies, and complete custom power systems.**

Information furnished by Vicor is believed to be accurate and reliable. However, no responsibility is assumed by Vicor for its use. Vicor components are not designed to be used in applications, such as life support systems, wherein a failure or malfunction could result in injury or death. All sales are subject to Vicor's Terms and Conditions of Sale, which are available upon request.

**Specifications are subject to change without notice.**

Vicor Corporation  
25 Frontage Road  
Andover, MA 01810  
USA

Picor Corporation  
51 Industrial Drive  
North Smithfield, RI 02896  
USA

Customer Service: [custserv@vicorpower.com](mailto:custserv@vicorpower.com)  
Technical Support: [apps@vicorpower.com](mailto:apps@vicorpower.com)  
Tel: 800-735-6200  
Fax: 978-475-6715