



Chipsmall Limited consists of a professional team with an average of over 10 year of expertise in the distribution of electronic components. Based in Hongkong, we have already established firm and mutual-benefit business relationships with customers from,Europe,America and south Asia,supplying obsolete and hard-to-find components to meet their specific needs.

With the principle of “Quality Parts,Customers Priority,Honest Operation,and Considerate Service”,our business mainly focus on the distribution of electronic components. Line cards we deal with include Microchip,ALPS,ROHM,Xilinx,Pulse,ON,Everlight and Freescale. Main products comprise IC,Modules,Potentiometer,IC Socket,Relay,Connector.Our parts cover such applications as commercial,industrial, and automotives areas.

We are looking forward to setting up business relationship with you and hope to provide you with the best service and solution. Let us make a better world for our industry!



Contact us

Tel: +86-755-8981 8866 Fax: +86-755-8427 6832

Email & Skype: info@chipsmall.com Web: www.chipsmall.com

Address: A1208, Overseas Decoration Building, #122 Zhenhua RD., Futian, Shenzhen, China



2.5Gbps x1 Lane Serial PCI Express Repeater/Equalizer with Clock Buffer

Features

- One high-speed PCI Express lane
- Adjustable Transmitter De-Emphasis & Amplitude
- Adjustable Receiver Equalization
- One Spread Spectrum Reference Clock Buffer Output
- 100Ω Differential CML I/O's
- Low Power (100mW per Channel)
- Stand-by Mode – Power Down State
- V_{CC} Operating Range: 1.8V ±0.1V
- Built in Clock Buffer
- Packaging (Pb-free & Green):
— 36-pad TQFN (ZF36)

Description

Pericom Semiconductor's PI2EQX4401 is a low power, PCI-Express compliant signal re-driver. The device provides programmable equalization, amplification, and de-emphasis by using 4 select bits, SEL[0:3], to optimize performance over a variety of physical mediums by reducing Inter-symbol interference. PI2EQX4401 supports two 100 Differential CML data I/O's between the Protocol ASIC to a switch fabric, across a backplane, or extends the signals across other distant data pathways on the user's platform.

The integrated equalization circuitry provides flexibility with signal integrity of the PCI Express signal before the re-driver. Whereas the integrated de-emphasis circuitry provides flexibility with signal integrity of the PCI Express signal after the re-driver.

In addition to providing signal re-conditioning, Pericom's PI2EQX4401 also provides power management Stand-by mode operated by a Bus Enable pin.

Block Diagram

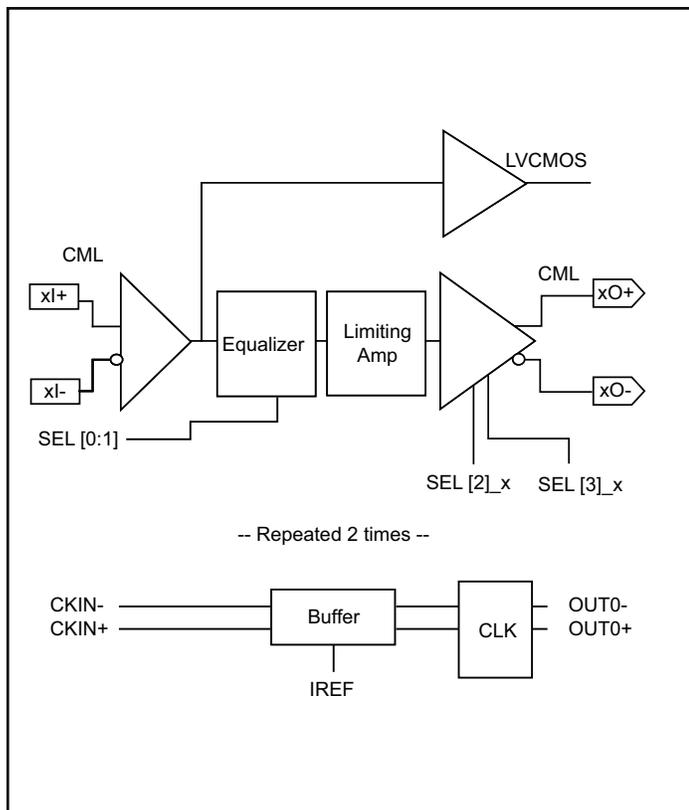

Pin Description

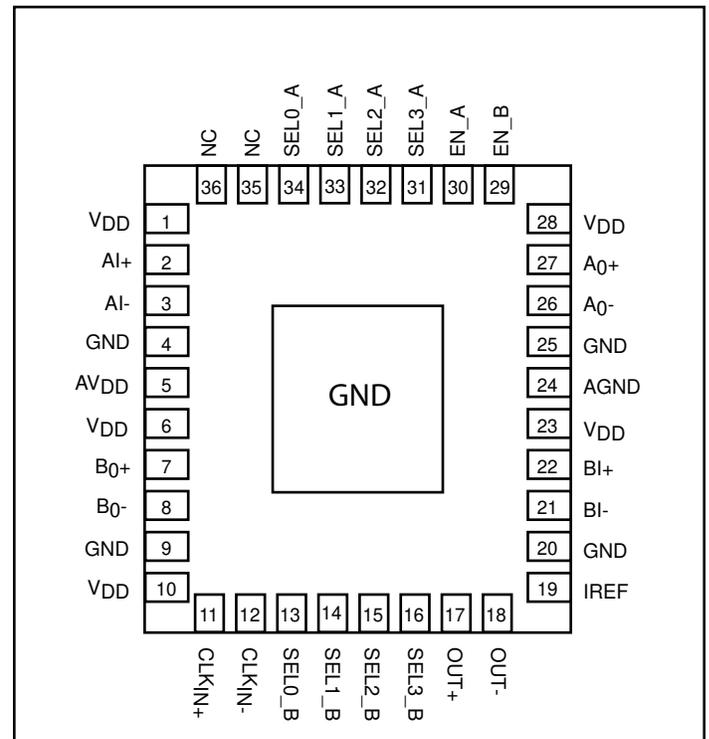

Pin Description

Pin #	Pin Name	I/O	Description
1, 6, 10, 23, 28	V _{DD}	PWR	1.8V Supply Voltage
2	AI+	I	Positive CML Input Channel A with internal 50Ω pull down
3	AI-	I	Negative CML Input Channel A with internal 50Ω pull down
4, 9, 20, 25	GND	PWR	Supply Ground
22	BI+	I	Positive CML Input Channel B with internal 50Ω pull down
21	BI-	I	Negative CML Input Channel B with internal 50Ω pull down
33, 34	SEL[0:1]_A	I	Selection pins for equalizer (see Amplifier Configuration Table) w/ 50KΩ internal pull up
13, 14	SEL[0:1]_B	I	
32	SEL[2]_A	I	Selection pins for amplifier (see Amplifier Configuration Table) w/ 50KΩ internal pull up
15	SEL[2]_B	I	
31	SEL[3]_A	I	Selection pins for De-Emphasis (See De-Emphasis Configuration Table) w/ 50KΩ internal pull up
16	SEL[3]_B	I	
27	AO+	O	Positive CML Output Channel A internal 50Ω pull up during normal operation and 2KΩ pull up otherwise.
26	AO-	O	Negative CML Output Channel A with internal 50Ω pull up during normal operation and 2KΩ pull up otherwise.
7	BO+	O	Positive CML Output Channel B with internal 50Ω pull up during normal operation and 2KΩ pull up otherwise.
8	BO-	O	Negative CML Output Channel B with internal 50Ω pull up during normal operation and 2KΩ pull up otherwise.
30, 29	EN_[A,B]	I	EN_[A:B] is the enable pin. A LVCMOS high provides normal operation. A LVCMOS low selects a low power down mode.
12	CLKIN-	I	Differential Input Reference Clock
11	CLKIN+	I	
17, 18	OUT+, OUT-	O	Differential Reference Clock Output
5	AVDD	PWR	1.8V Analog supply voltage
24	AGND	PWR	Analog ground
19	IREF	O	External 475Ω resistor connection to set the differential output current
35, 36	NC	N/A	No connect pins. For normal operation, leave pins floating

Maximum Ratings

(Above which useful life may be impaired. For user guidelines, not tested.)

Storage Temperature.....	-65°C to +150°C
Supply Voltage to Ground Potential.....	-0.5V to +2.5V
DC SIG Voltage.....	-0.5V to V _{CC} +0.5V
Current Output	-25mA to +25mA
Power Dissipation Continuous.....	500mW
Operating Temperature.....	0 to +70°C

Note:

Stresses greater than those listed under MAXIMUM RATINGS may cause permanent damage to the device. This is a stress rating only and functional operation of the device at these or any other conditions above those indicated in the operational sections of this specification is not implied. Exposure to absolute maximum rating conditions for extended periods may affect reliability.

Output Swing Control

SEL2_[A:B]	Swing
0	1x
1	1.2x

Output De-emphasis Adjustment

SEL3_[A:B]	De-emphasis
0	0dB
1	-3.5dB

Equalizer Selection

SEL0_[A:B]	SEL1_[A:B]	Compliance Channel
0	0	no equalization
0	1	[0:2.5dB] @ 1.25 GHz
1	0	[2.5:4.5dB] @ 1.25 GHz
1	1	[4.5:6.5dB] @ 1.25 GHz

AC/DC Electrical Characteristics ($V_{DD} = 1.8 \pm 0.1V$)

Symbol	Parameter	Conditions	Min.	Typ.	Max.	Units
Ps	Supply Power	EN = LVCMOS Low			0.1	W
		EN = LVCMOS High			0.3	
	Latency	From input to output		2.0		ns
CML Receiver Input						
RL _{RX}	Return Loss	50 MHz to 1.25 GHz		12		dB
V _{RX-DIFFP-P}	Differential Input Peak-to-peak Voltage		0.175		1.200	V
V _{RX-CM-ACP}	AC Peak Common Mode Input Voltage				150	mV
Z _{RX-DIFF-DC}	DC Differential Input Impedance		80	100	120	Ω
Z _{RX-DC}	DC Input Impedance		40	50	60	
Equalization						
J _{RS}	Residual Jitter ^(1,2)	Total Jitter			0.3	Ulp-p
		Deterministic jitter			0.2	
J _{RM}	Random Jitter ^(1,2)			1.5		psrms

Notes

1. K28.7 pattern is applied differentially at point A as shown in Figure 1.
2. Total jitter does not include the signal source jitter. Total jitter (TJ) = (14.1 × RJ + DJ) where RJ is random RMS jitter and DJ is maximum deterministic jitter. Signal source is a K28.5 ± pattern (00 1111 1010 11 0000 0101) for the deterministic jitter test and K28.7 (0011111000) or equivalent for random jitter test. Residual jitter is that which remains after equalizing media-induced losses of the environment of Figure 1 or its equivalent. The deterministic jitter at point B must be from media-induced loss, and not from clock source modulation. Jitter is measured at 0V at point C of Figure 1.

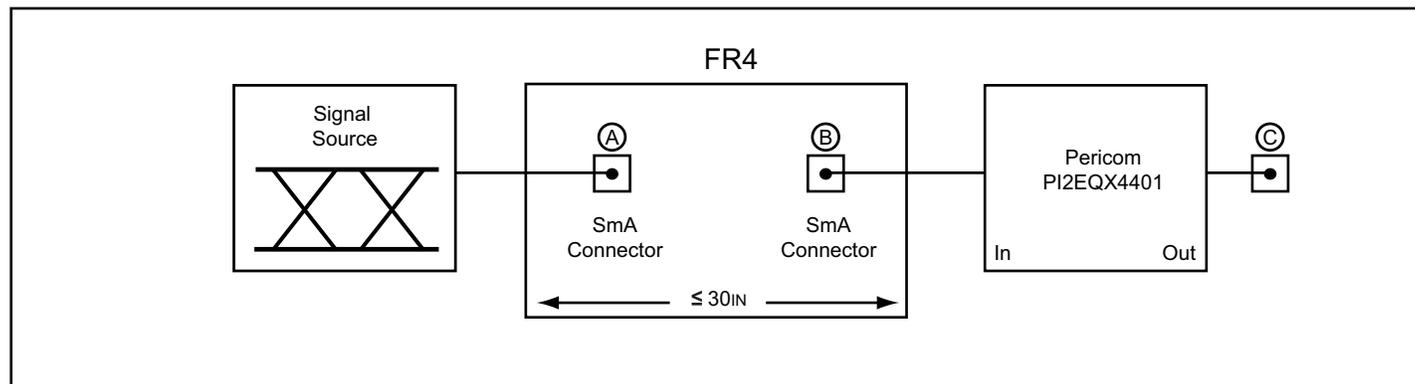

Figure 1. Test Condition Referenced in the Electrical Characteristic Table

AC/DC Electrical Characteristics ($T_A = 0$ to 70°C)

Symbol	Parameter	Conditions	Min.	Typ.	Max.	Units
CML Transmitter Output (100Ω differential)						
V_{DIFFP}	Output Voltage Swing	Differential Swing $ V_{\text{TX-D+}} - V_{\text{TX-D-}} $	400		900	mVp-p
$V_{\text{TX-C}}$	Common-Mode Voltage	$ V_{\text{TX-D+}} + V_{\text{TX-D-}} / 2$		$V_{\text{CC}} - 0.3$		
t_F, t_R	Transition Time	20% to 80% ⁽¹⁾			150	ps
Z_{OUT}	Output resistance	Single ended	40	50	60	Ω
$Z_{\text{TX-DIFF-DC}}$	DC Differential TX Impedance		80	100	120	Ω
C_{TX}	AC Coupling Capacitor		75		200	nF
$V_{\text{TX-DIFFP-P}}$	Differential Peak-to-peak Output Voltage	$V_{\text{TX-DIFFP-P}} = 2 * V_{\text{TX-D+}} - V_{\text{TX-D-}} $	0.8		1.8	V
LVC MOS Control Pins						
V_{IH}	Input High Voltage		$0.65 \times V_{\text{DD}}$			V
V_{IL}	Input Low Voltage				$0.35 \times V_{\text{DD}}$	
I_{IH}	Input High Current				250	μA
I_{IL}	Input Low Current				500	

Note:

- Using K28.7 (0011111000) pattern)

AC Switching Characteristics for Clock Buffer ($V_{DD} = 1.8 \pm 0.1V$, $AV_{DD} = 1.8 \pm 0.1V$) ⁽³⁾

Symbol	Parameters	Min	Max.	Units	Notes
T_{rise} / T_{fall}	Rise and Fall Time (measured between 0.175V to 0.525V) ⁽¹⁾	125	525	ps	1
$\Delta T_{rise} / \Delta T_{fall}$	Rise and Fall Time Variation		75		1
V_{HIGH}	Voltage High including overshoot	660	900	mV	1
V_{LOW}	Voltage Low including undershoot	-200			1
V_{CROSS}	Absolute crossing point voltages	200	550		1
ΔV_{CROSS}	Total Variation of V_{cross} over all edges		250		1
T_{DC}	Duty Cycle (input duty cycle = 50%) ⁽²⁾	45	55	%	2

Notes:

1. Measurement taken from Single Ended waveform.
2. Measurement taken from Differential waveform.
3. Test configuration is $R_S = 33.2\Omega$, $R_p = 49.9\Omega$, and 2pF.

Configuration Test Load Board Termination

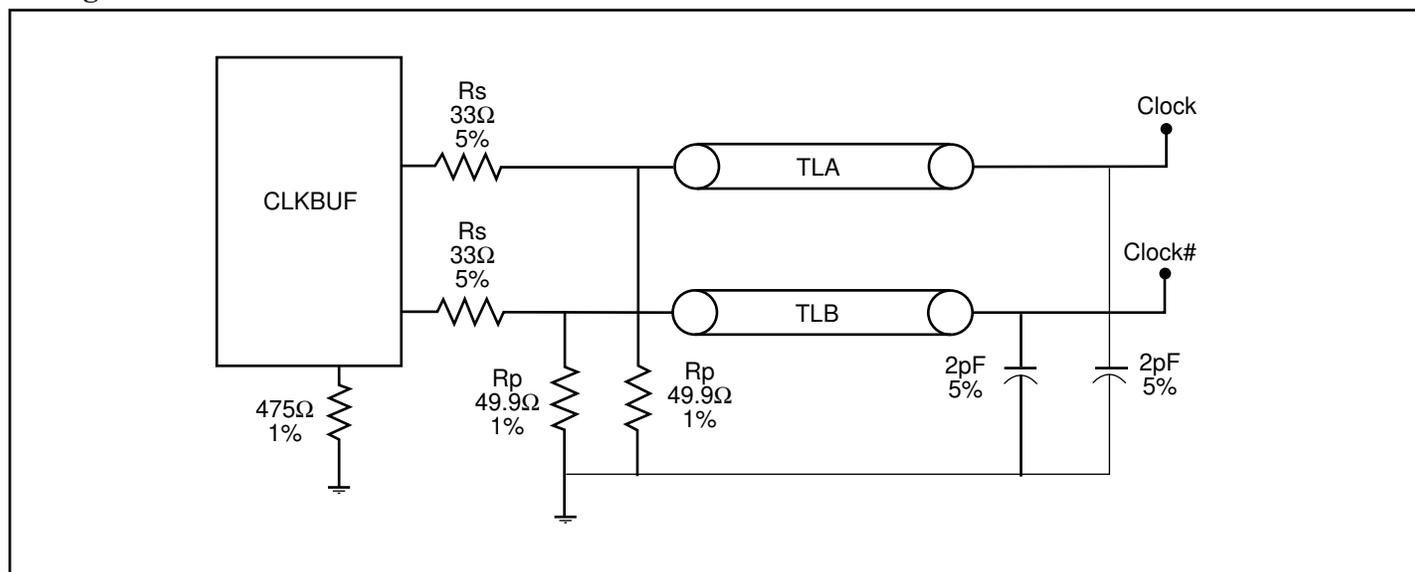
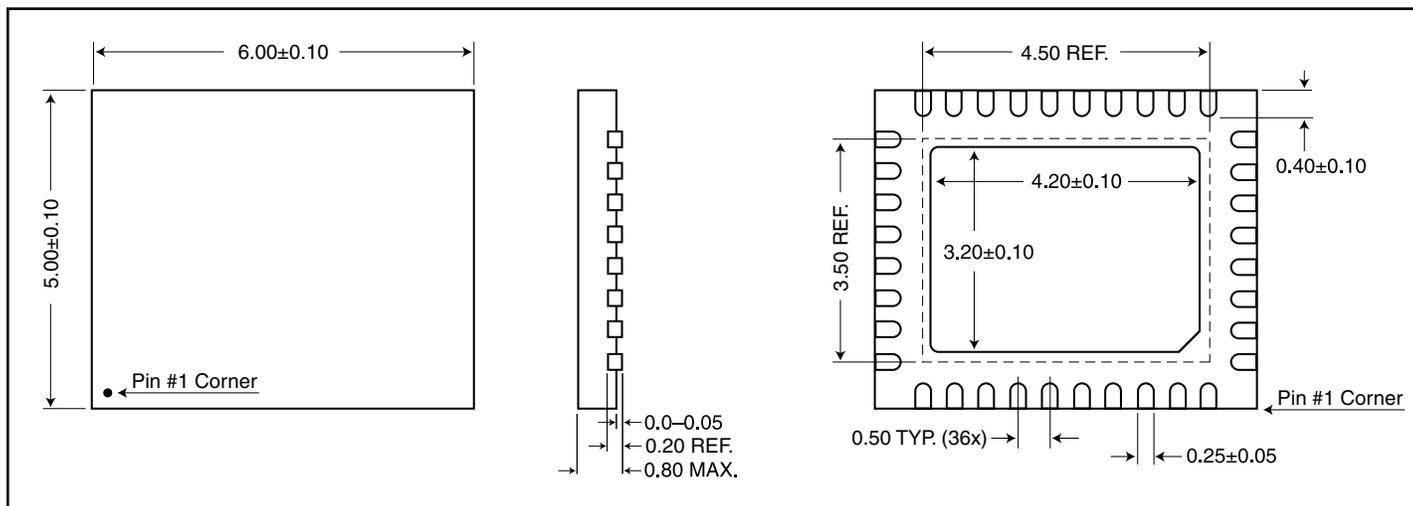

Figure 2. Configuration test load board termination

Note:

- TLA and TLB are 3" transmission lines.

Packaging Mechanical: 36-pad TQFN (ZF36)

Ordering Information

Ordering Number	Package Code	Package Description
PI2EQX4401ZFE	ZF	Pb-Free and Green 36-pad TQFN

Notes:

- Thermal characteristics can be found on the company web site at www.pericom.com/packaging/
- E = Pb-free & Green
- X suffix = Tape/Reel