



Chipsmall Limited consists of a professional team with an average of over 10 year of expertise in the distribution of electronic components. Based in Hongkong, we have already established firm and mutual-benefit business relationships with customers from,Europe,America and south Asia,supplying obsolete and hard-to-find components to meet their specific needs.

With the principle of "Quality Parts,Customers Priority,Honest Operation,and Considerate Service",our business mainly focus on the distribution of electronic components. Line cards we deal with include Microchip,ALPS,ROHM,Xilinx,Pulse,ON,Everlight and Freescale. Main products comprise IC,Modules,Potentiometer,IC Socket,Relay,Connector.Our parts cover such applications as commercial,industrial, and automotives areas.

We are looking forward to setting up business relationship with you and hope to provide you with the best service and solution. Let us make a better world for our industry!



Contact us

Tel: +86-755-8981 8866 Fax: +86-755-8427 6832

Email & Skype: info@chipsmall.com Web: www.chipsmall.com

Address: A1208, Overseas Decoration Building, #122 Zhenhua RD., Futian, Shenzhen, China



2.5 Gbps x2 Lane Serial PCI Express Repeater/Equalizer with Signal Detect feature

Features

- Two High Speed PCI Express lanes
- Supports PCI Express data rates (2.5 Gbps) on each lane
- Adjustable Transmitter De-Emphasis & Amplitude
- Adjustable Receiver Equalization
- Input Signal Level Detect & Output Squelch on all Channels
- Two Spread Spectrum Reference Clock Buffer Outputs
- 100Ω Differential CML I/O's
- Low Power (100mW per Channel)
- Standby Mode – Power Down State
- V_{DD} Operating Range: 1.8V +/-0.1V
- Packaging (Pb-free & Green): 84-ball LFBGA (NB84)

Description

Pericom Semiconductor's PI2EQX4402D is a low power, PCI Express compliant signal Re-Driver. The device provides programmable equalization, amplification, and de-emphasis by using 7 select bits, SEL[0:6], to optimize performance over a variety of physical mediums by reducing Inter-symbol interference. PI2EQX4402D supports four 100-ohm Differential CML data I/O's between the Protocol ASIC to a switch fabric, across a backplane, or extends the signals across other distant data pathways on the user's platform.

The integrated equalization circuitry provides flexibility with signal integrity of the PCI Express signal before the Re-Driver. Whereas the integrated de-emphasis circuitry provides flexibility with signal integrity of the PCI Express signal after the Re-Driver.

A low-level input signal detection and output squelch function is provided for all four channels. Each channel operates fully independantly. When a channel is enabled (EN_x=1) and operating, that channel input signal level (on xI₊/-) determines whether the output is enabled. If the input level of the channel falls below the active threshold level (V_{th}-) then the output driver switches off, and the pin is pulled to VDD via a high impedance resistor.

In addition to providing signal re-conditioning, Pericom's PI2EQX4402D also provides power management Stand-by mode operated by an Enable pin. A differential clock buffer is provided for test and other system requirements. This clock function is not used by the data channels.

Block Diagram

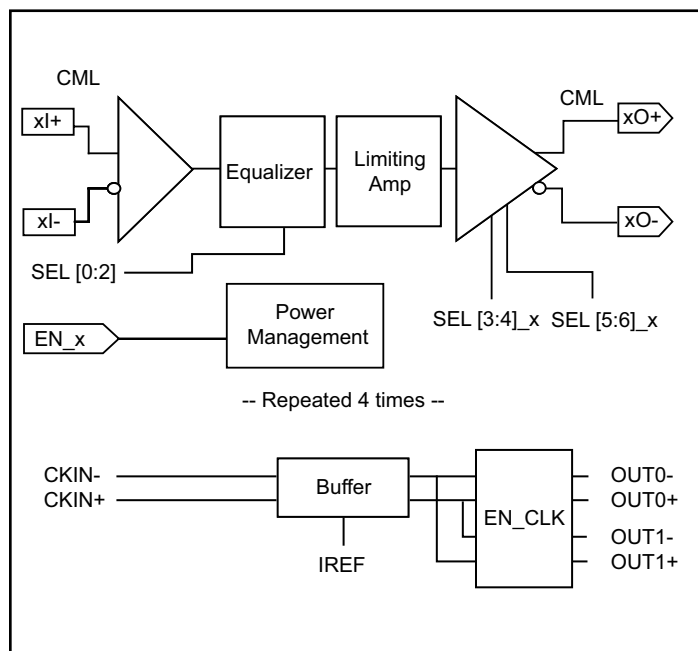

Pin Description (Top View)

	1	2	3	4	5	6	7	8	9	10
A	SD_C	SD_D	SELO_A	SELO_B	SEL4_A	SEL4_B	SEL6_A	SEL6_B	EN_A	EN_B
B	V _{DD}	SD_B	V _{DD}	SEL1_A	SEL2_A	SEL3_A	SEL5_A	V _{DD}	EN_C	V _{DD}
C	BO+	SD_A	AI+	SEL1_B	SEL2_B	SEL3_B	SEL5_B	BI+	EN_D	AO+
D	BO-	V _{DD}	AI-	84-Ball LFBGA				BI-	GND	AO-
E	GND	V _{DD}	GND					GND	GND	GND
F	V _{DD}	GND	V _{DD}					V _{DD}	GND	V _{DD}
G	DO+	SELO_C	CI+					DI+	SEL6_C	CO+
H	DO-	SELO_D	CI-	V _{DD}	CKIN+	CKIN-	GND	DI-	SEL6_D	CO-
J	GND	SEL1_C	GND	SEL2_C	SEL2_D	SEL3_D	IREF	GND	SEL4_D	GND
K	EN_CLK	SEL1_D	SEL3_C	SEL4_C	OUT0+	OUT0-	OUT1+	OUT1-	SEL5_C	SEL5_D

Pin Description

Pin #	Pin Name	I/O	Description
B1, F1, D2, E2, B3, F3, H4, B8, F8, B10, F10	V _{DD}	PWR	1.8V Supply Voltage
C3	AI+	I	Positive CML Input Channel A with internal 50Ω pull down during normal operation (EN_A=1). When EN_A=0, this pin is high impedance.
D3	AI-	I	Negative CML Input Channel A with internal 50Ω pull down during normal operation (EN_A=1). When EN_A=0, this pin is high impedance.
E1, J1, F2, E3, J3, H7, E8, J8, D9, E9, F9, E10, J10	GND	PWR	Supply Ground
C8	BI+	I	Positive CML Input Channel B with internal 50Ω pull down during normal operation (EN_B=1). When EN_B=0, this pin is high impedance.
D8	BI-	I	Negative CML Input Channel B with internal 50Ω pull down during normal operation (EN_B=1). When EN_B=0, this pin is high impedance.
G3	CI+	I	Positive CML Input Channel C with internal 50Ω pull down during normal operation (EN_C=1). When EN_C=0, this pin is high impedance.
H3	CI-	I	Negative CML Input Channel C with internal 50Ω pull down during normal operation (EN_C=1). When EN_C=0, this pin is high impedance.
G8	DI+	I	Positive CML Input Channel D with internal 50Ω pull down during normal operation (EN_D=1). When EN_D=0, this pin is high impedance.
H8	DI-	I	Negative CML Input Channel D with internal 50Ω pull down during normal operation (EN_D=1). When EN_D=0, this pin is high impedance.
A3, B4, B5	SEL[0:2]_A	I	Selection pins for equalizer (see Amplifier Configuration Table) w/ 50KΩ internal pull up
A4, C4, C5	SEL[0:2]_B	I	
G2, J2, J4	SEL[0:2]_C	I	
H2, K2, J5	SEL[0:2]_D	I	
B6, A5	SEL[3:4]_A	I	Selection pins for amplifier (see Amplifier Configuration Table) w/ 50KΩ internal pull up
C6, A6	SEL[3:4]_B	I	
K3, K4	SEL[3:4]_C	I	
J6, J9	SEL[3:4]_D	I	
B7, A7	SEL[5:6]_A	I	Selection pins for De-Emphasis (See De-Emphasis Configuration Table) w/ 50KΩ internal pull up
C7, A8	SEL[5:6]_B	I	
K9, G9	SEL[5:6]_C	I	
K10, H9	SEL[5:6]_D	I	
C10	AO+	O	Positive CML Output Channel A internal 50Ω pull up during normal operation and 2KΩ pull up otherwise.
D10	AO-	O	Negative CML Output Channel A with internal 50Ω pull up during normal operation and 2KΩ pull up otherwise.
C1	BO+	O	Positive CML Output Channel B with internal 50Ω pull up during normal operation and 2KΩ pull up otherwise.
D1	BO-	O	Negative CML Output Channel B with internal 50Ω pull up during normal operation and 2KΩ pull up otherwise.
G10	CO+	O	Positive CML Output Channel C with internal 50Ω pull up during normal operation and 2KΩ pull up otherwise.
H10	CO-	O	Negative CML Output Channel C with internal 50Ω pull up during normal operation and 2KΩ pull up otherwise.

Pin Description (Continued)

Pin #	Pin Name	I/O	Description
GI	DO+	O	Positive CML Output Channel D with internal 50Ω pull up during normal operation and 2KΩ pull up otherwise.
HI	DO-	O	Negative CML Output Channel D with internal 50Ω pull up during normal operation and 2KΩ pull up otherwise.
A9, A10, B9, C9	EN_ [A,B,C,D]	I	EN_[A:D] is the enable pin with internal 50KΩ pull up resistor. A LVCMOS high provides normal operation. A LVCMOS low selects a low power down mode.
H6	CKIN-	I	Differential Input Reference Clock
H5	CKIN+	I	
K5, K6	OUT0+, OUT0-	O	Differential Reference Clock Output
K7, K8	OUT1+, OUT1-	O	
J7	IREF	O	External 475Ω resistor connection to set the differential output current
K1	EN_CLK	I	Enable output clock pin with internal 50kΩ pull up resistor. When EN_CLK is LVCMOS high level, the clock output operates normally. When EN_CLK = low, the clock outputs are turned off for power savings. A clock is not required by the data channels for operation.
C2, B2, A1, A2	SD_ [A,B,C,D]	N/A	Signal detected, channels A, B, C, D. Indicated a valid signal level on the channels input pin pair when active high. When low, SD indicates the input signal level is below the signal detect threshold level.

Inputs	Outputs
EN_[A, B, C, D]	O+ / O-
High	Normal output
Low	No output

Inputs	Clock Outputs
EN_CLK	
High	Clock output
Low	No clock output

Output Swing Control

SEL3_[A:D]	SEL4_[A:D]	Swing
0	0	1x
0	1	0.8x
1	0	1.2x
1	1	1.4x

Output De-emphasis Adjustment

SEL5_[A:D]	SEL6_[A:D]	De-emphasis
0	0	0dB
0	1	-2.5dB
1	0	-3.5dB
1	1	-4.5dB

Equalizer Selection

SEL0_[A:D]	SEL1_[A:D]	SEL2_[A:D]	Compliance Channel
0	0	0	No Equalization
0	0	1	[0:1.5dB] @ 1.25 GHz
0	1	0	[0:2.5dB] @ 1.25 GHz
0	1	1	[0:3.5dB] @ 1.25 GHz
1	0	0	[0:4.5dB] @ 1.25 GHz
1	0	1	[0:5.5dB] @ 1.25 GHz
1	1	0	[0:6.5dB] @ 1.25 GHz
1	1	1	[0:7.5dB] @ 1.25 GHz

Maximum Ratings

(Above which useful life may be impaired. For user guidelines, not tested.)

Storage Temperature.....	-65°C to +150°C
Supply Voltage to Ground Potential.....	-0.5V to +2.5V
DC SIG Voltage.....	-0.5V to V _{DD} +0.5V
Current Output.....	-25mA to +25mA
Power Dissipation Continuous.....	800mW
Operating Temperature.....	0 to +70°C

Note:

Stresses greater than those listed under MAXIMUM RATINGS may cause permanent damage to the device. This is a stress rating only and functional operation of the device at these or any other conditions above those indicated in the operational sections of this specification is not implied. Exposure to absolute maximum rating conditions for extended periods may affect reliability.

AC/DC Electrical Characteristics for 2.5 Gbps Quad Repeater/Equalizer (V_{DD} = 1.8 ±0.1V)

Symbol	Parameter	Conditions	Min.	Typ.	Max.	Units
Ps	Supply Power	EN = LVCMOS Low			0.1	W
		EN = LVCMOS High			0.6	
	Latency	From input to output		2.0		ns
CML Receiver Input						
V _{RX-DIFFP-P}	Differential Input Peak-to-peak Voltage		0.175		1.200	V
V _{RX-CM-ACP}	AC Peak Common Mode Input Voltage				150	mV
V _{TH-}	Signal Detect Threshold	E _{N_X} = High		120	175	mV
Z _{RX-DIFF-DC}	DC Differential Input Impedance		80	100	120	Ω
Z _{RX-DC}	DC Input Impedance		40	50	60	
Equalization						
J _{RS}	Residual Jitter ^(1,2)	Total Jitter			0.3	Ulp-p
		Deterministic jitter			0.2	
J _{RM}	Random Jitter ^(1,2)			1.5		psrms

Notes

1. K28.7 pattern is applied differentially at point A as shown in Figure 1.
2. Total jitter does not include the signal source jitter. Total jitter (TJ) = (14.1 × RJ + DJ) where RJ is random RMS jitter and DJ is maximum deterministic jitter. Signal source is a K28.5 ± pattern (00 1111 1010 11 0000 0101) for the deterministic jitter test and K28.7 (0011111000) or equivalent for random jitter test. Residual jitter is that which remains after equalizing media-induced losses of the environment of Figure 1 or its equivalent. The deterministic jitter at point B must be from media-induced loss, and not from clock source modulation. Jitter is measured at 0V at point C of Figure 1.

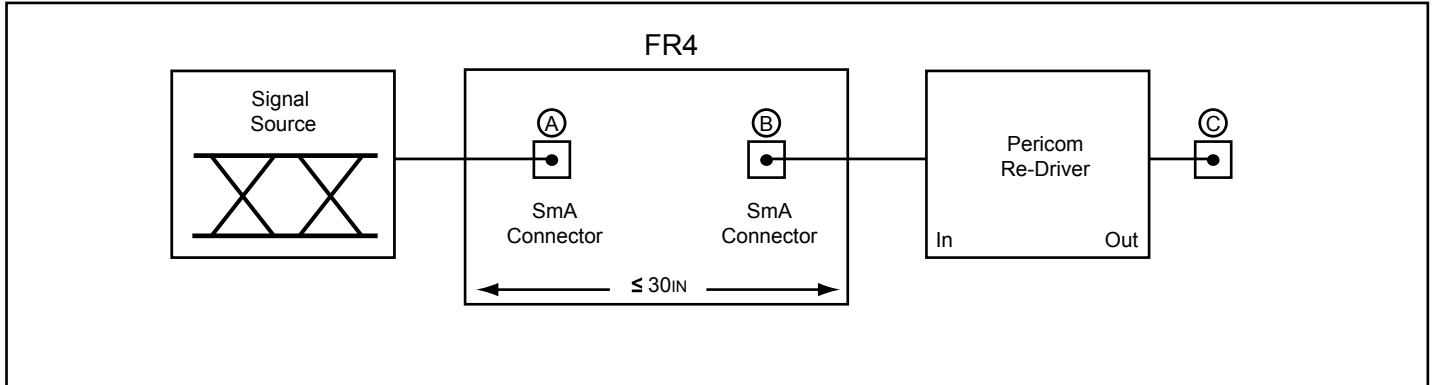

Figure 1. Test Condition Referenced in the Electrical Characteristic Table

AC/DC Electrical Characteristics for 2.5 Gbps x2 Lane Repeater/Equalizer (TA = 0 to 70°C)

Symbol	Parameter	Conditions	Min.	Typ.	Max.	Units
CML Transmitter Output (100Ω differential)						
V _{DIFFP}	Output Voltage Swing	Differential Swing V _{TX-D+} - V _{TX-D-}	400		900	mVp-p
V _{TX-C}	Common-Mode Voltage	V _{TX-D+} + V _{TX-D-} / 2		V _{DD} -0.3		
t _F , t _R	Transition Time	20% to 80% ⁽¹⁾			150	ps
Z _{OUT}	Output resistance	Single ended	40	50	60	Ω
Z _{TX-DIFF-DC}	DC Differential TX Impedance		80	100	120	Ω
C _{TX}	AC Coupling Capacitor		75		200	nF
V _{TX-DIFFP-P}	Differential Peak-to-peak Output Voltage	V _{TX-DIFFP-P} = 2 * V _{TX-D+} - V _{TX-D-}	0.8		1.8	V
LVC MOS Control Pins						
V _{IH}	Input High Voltage		0.65 × V _{DD}		V _{DD}	V
V _{IL}	Input Low Voltage				0.35 × V _{DD}	
I _{IH}	Input High Current				250	μA
I _{IL}	Input Low Current				500	

Note:

- Using K28.7 (0011111000) pattern)

AC Switching Characteristics for Clock Buffer ($V_{DD} = 1.8 \pm 0.1V$, $AV_{DD} = 1.8 \pm 0.1V$) ⁽³⁾

Symbol	Parameters	Min	Max.	Units	Notes
T_{rise} / T_{fall}	Rise and Fall Time (measured between 0.175V to 0.525V) ⁽¹⁾	125	525	ps	1
$\Delta T_{rise} / \Delta T_{fall}$	Rise and Fall Time Variation		75		1
V_{HIGH}	Voltage High including overshoot	660	900	mV	1
V_{LOW}	Voltage Low including undershoot	-200			1
V_{CROSS}	Absolute crossing point voltages	200	550		1
ΔV_{CROSS}	Total Variation of V_{cross} over all edges		250		1
T_{DC}	Duty Cycle (input duty cycle = 50%) ⁽²⁾	45	55	%	2

Notes:

1. Measurement taken from Single Ended waveform.
2. Measurement taken from Differential waveform.
3. Test configuration is $R_S = 33.2\Omega$, $R_p = 49.9\Omega$, and 2pF.

Configuration Test Load Board Termination

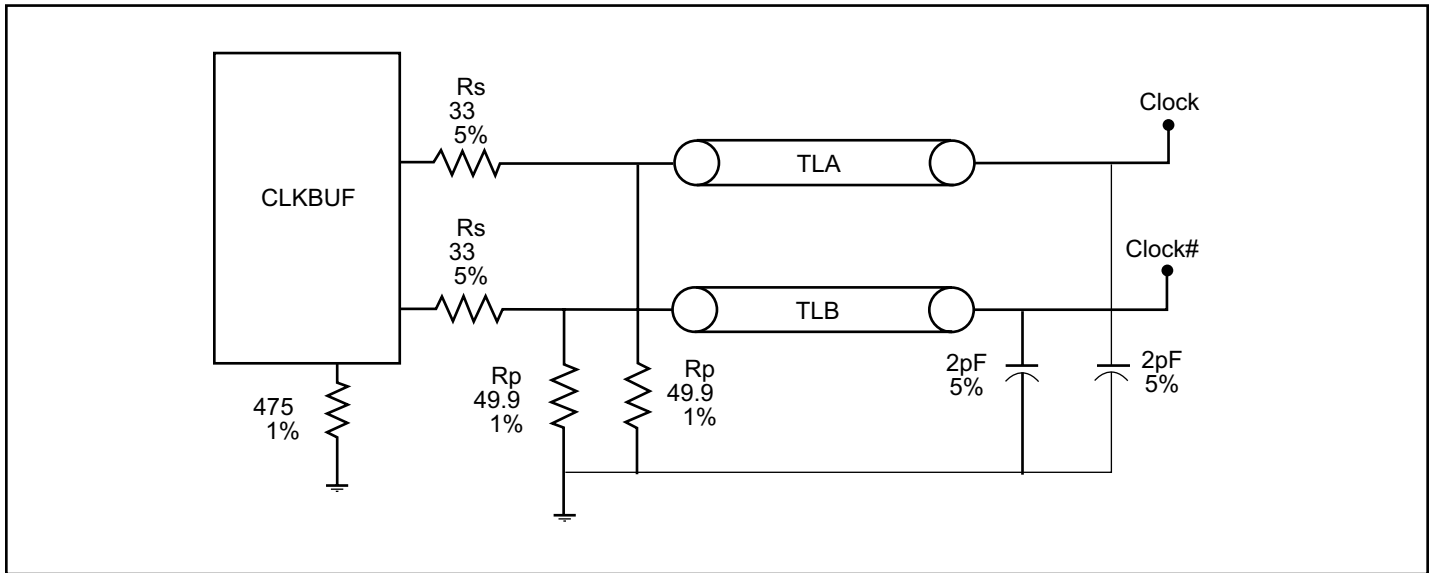
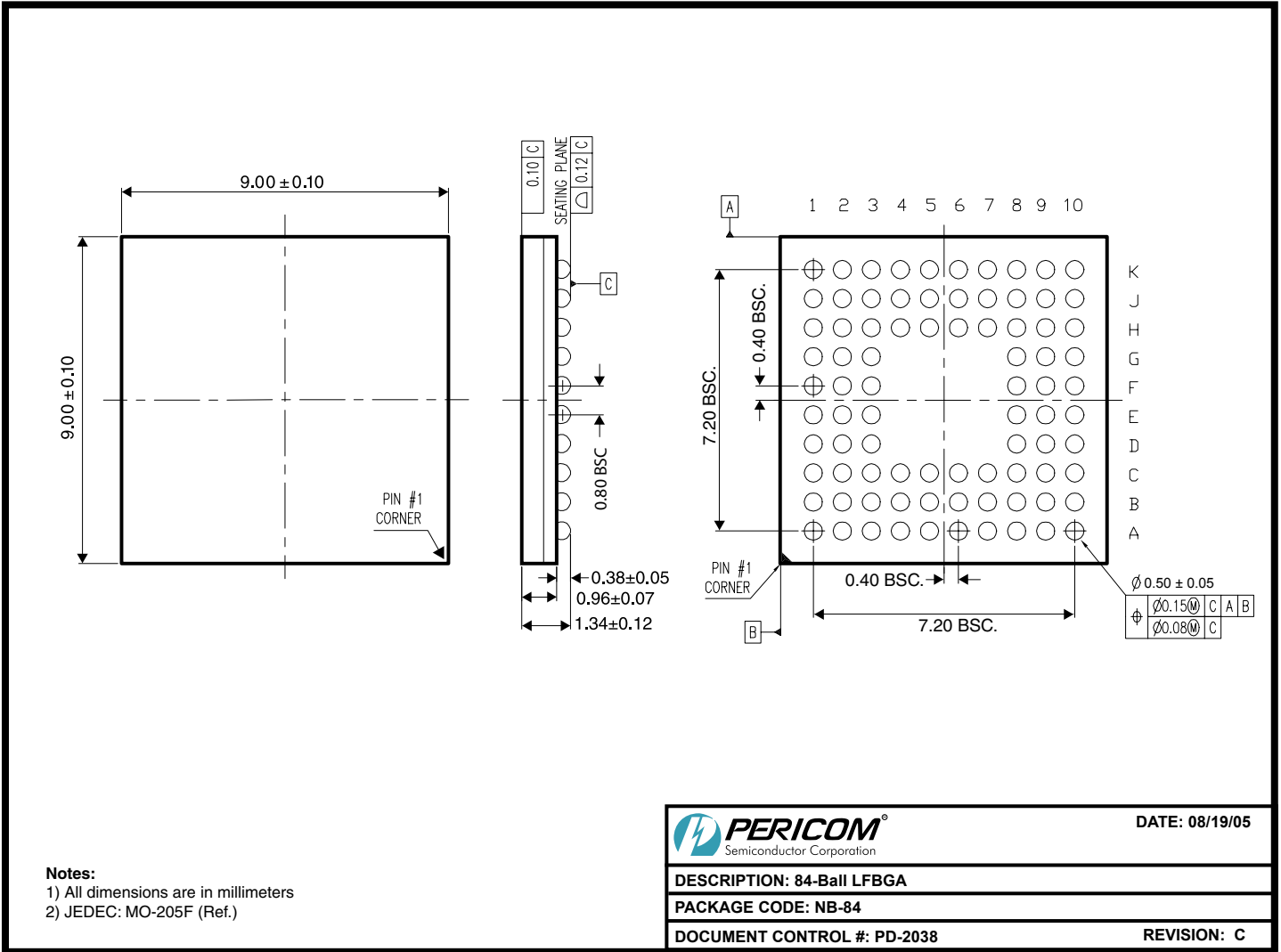

Figure 2. Configuration test load board termination

Note:

- TLA and TLB are 3" transmission lines.



Ordering Information

Ordering Number	Package Code	Package Description
PI2EQX4402DNBE	NB	Pb-free & Green 84-Ball LFBGA

Notes:

- Thermal characteristics can be found on the company web site at www.pericom.com/packaging/
- E = Pb-free & Green
- X suffix = Tape/Reel