



Chipsmall Limited consists of a professional team with an average of over 10 year of expertise in the distribution of electronic components. Based in Hongkong, we have already established firm and mutual-benefit business relationships with customers from,Europe,America and south Asia,supplying obsolete and hard-to-find components to meet their specific needs.

With the principle of “Quality Parts,Customers Priority,Honest Operation,and Considerate Service”,our business mainly focus on the distribution of electronic components. Line cards we deal with include Microchip,ALPS,ROHM,Xilinx,Pulse,ON,Everlight and Freescale. Main products comprise IC,Modules,Potentiometer,IC Socket,Relay,Connector.Our parts cover such applications as commercial,industrial, and automotives areas.

We are looking forward to setting up business relationship with you and hope to provide you with the best service and solution. Let us make a better world for our industry!



Contact us

Tel: +86-755-8981 8866 Fax: +86-755-8427 6832

Email & Skype: info@chipsmall.com Web: www.chipsmall.com

Address: A1208, Overseas Decoration Building, #122 Zhenhua RD., Futian, Shenzhen, China



5.0 Gbps USB 3.0 Compatible Single Switch
Features

- USB 3.0 Signal Switch
- 2 Differential Channel, 2:1 Mux/DeMux
- -3dB BW of 4.1GHz
- Low Bit-to-Bit Skew, 6ps max
- Low Insertion Loss: -2.0dB@2.5GHz(5.0Gbps)
- Low Crosstalk: -41dB@2.5GHz (5.0Gbps)
- Low Off Isolation: -22dB@2.5GHz (5.0Gbps)
- V_{DD} Operating Range: 1.5V or 1.8V
- ESD Tolerance 2KV HBM I/O
- Packaging (Pb-free & Green):
 - 28-Pin TQFN (ZH, 3.5 × 5.5mm)

Description

Pericom Semiconductor's PI2USB3212 is a 1 to 2 bi-directional differential channel multiplexer/demultiplexer switch supporting 5.0 Gbps applications, such as USB 3.0. Due to its low bit-to-bit skew, high channel-to-channel noise isolation and high bandwidth, this product is ideal for switching two sources to a single receiver, or alternatively, one source to two receivers.

Application

- USB 3.0, XAUI, Infiniband, Rapid I/O PCIe® 2.0.
- Computers, servers, storage, instrumentation, telecom, networking.

Truth Table

Function	SEL
A to B	L
A to C	H

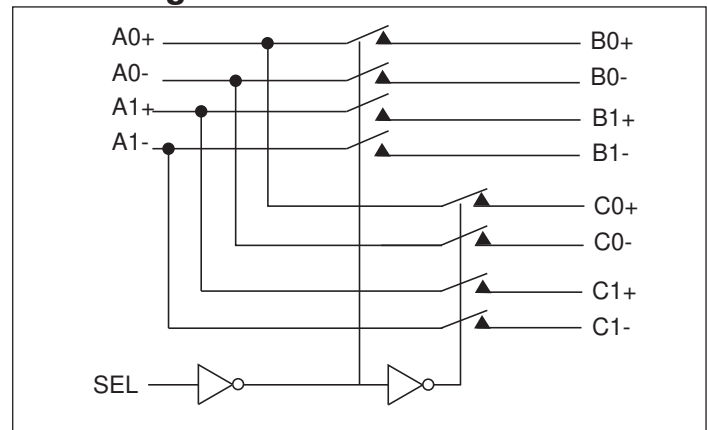
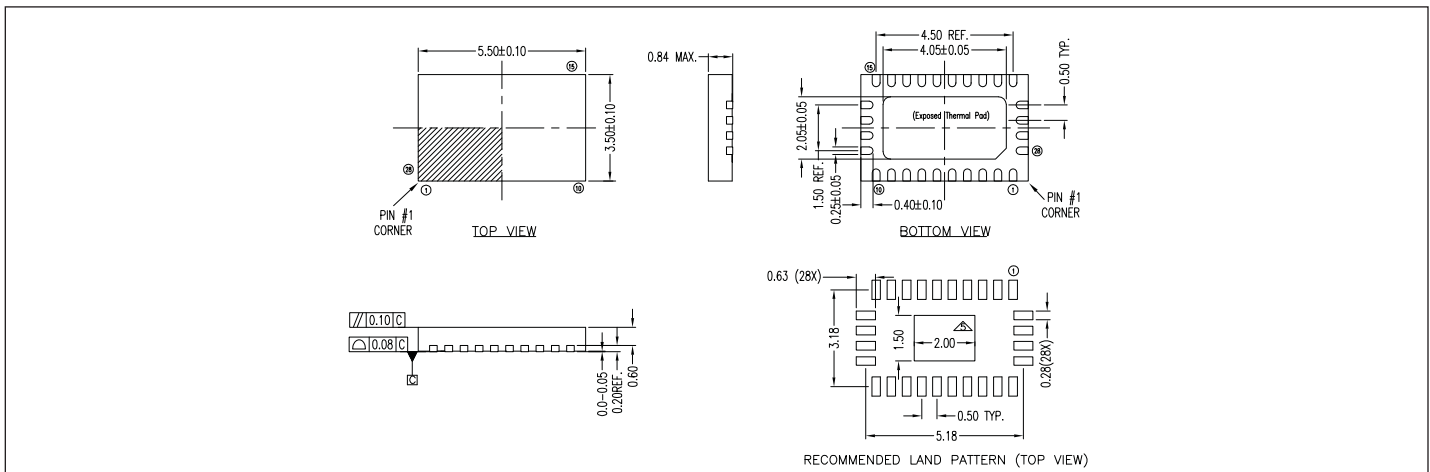
Block Diagram

Package Mechanical: 28-Pin, TQFN (ZH)

Ordering Information

Ordering Code	Package Code	Package Type
PI2USB3212ZHE	ZH	Pb-free & Green, 28-Contact TQFN

1. Thermal characteristics can be found on the company web site at www.pericom.com/packaging/
2. E = Pb-free and Green
3. Adding an X Suffix = Tape/Reel