



Chipsmall Limited consists of a professional team with an average of over 10 year of expertise in the distribution of electronic components. Based in Hongkong, we have already established firm and mutual-benefit business relationships with customers from,Europe,America and south Asia,supplying obsolete and hard-to-find components to meet their specific needs.

With the principle of “Quality Parts,Customers Priority,Honest Operation,and Considerate Service”,our business mainly focus on the distribution of electronic components. Line cards we deal with include Microchip,ALPS,ROHM,Xilinx,Pulse,ON,Everlight and Freescale. Main products comprise IC,Modules,Potentiometer,IC Socket,Relay,Connector.Our parts cover such applications as commercial,industrial, and automotives areas.

We are looking forward to setting up business relationship with you and hope to provide you with the best service and solution. Let us make a better world for our industry!



Contact us

Tel: +86-755-8981 8866 Fax: +86-755-8427 6832

Email & Skype: info@chipsmall.com Web: www.chipsmall.com

Address: A1208, Overseas Decoration Building, #122 Zhenhua RD., Futian, Shenzhen, China



High Speed, Dual DPDT Analog Switch

Features

- ➔ CMOS Technology for Analog Applications
- ➔ Low On-Resistance: 2.0Ω
- ➔ Wide VCC Range: +1.65V to +4.3V
- ➔ ICC Maximum 1μA @ TA = +25°C
- ➔ Rail-to-Rail Switching Throughout Signal Range
- ➔ Fast Switching Speed: 10ns TYP. at 3.0V
- ➔ High Off Isolation: -67dB@1MHz
- ➔ Crosstalk Rejection: -100dB@1MHz
- ➔ Wide Bandwidth: 330MHz
- ➔ Interfaces with 1.8V Chipset
- ➔ High ESD performance : 8kV for I/O to GND
- ➔ Extended Industrial Temperature Range: -40°C to 85°C
- ➔ Packaging (Pb-free & Green): UQFN-16 1.8mmx2.6mm

Block Diagram

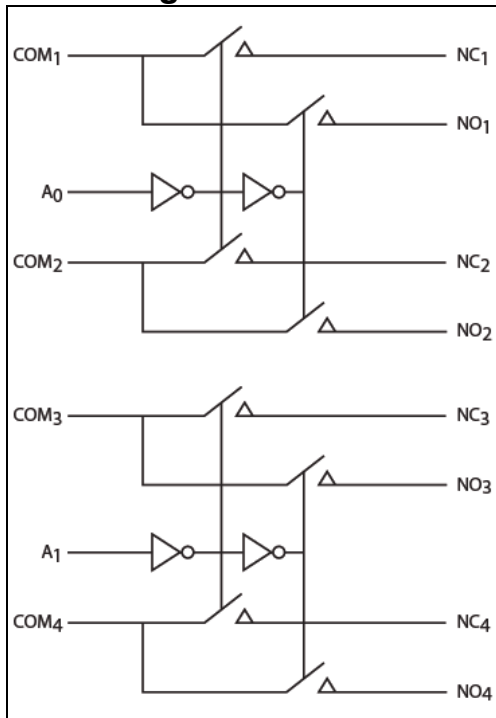

Function Truth Table

A ₀	Function	A ₁	Function
0	NC _{1,2} Connected to COM _{1,2}	0	NC _{3,4} Connected to COM _{3,4}
1	NO _{1,2} Connected to COM _{1,2}	1	NO _{3,4} Connected to COM _{3,4}

Description

The PI3A3899 is a dual double-pole double-throw (DPDT) CMOS switch. It can be used as low power audio and dual SIM card applications. Specified over a wide operating power supply voltage range, +1.65V to +4.3V, the switch has a low On-Resistance of 2.4Ω at 3.0V.

Control inputs, Ax, tolerate input drive signals up to 5V, independent of supply voltage.

Applications

- ➔ Cell Phones
- ➔ PDAs
- ➔ Portable Instrumentation Battery Powered
- ➔ Computer Peripherals
- ➔ Dual SIM Card Switching

Pin Configuration

UQFN16 1.8mmx2.6mm Package (Top View)

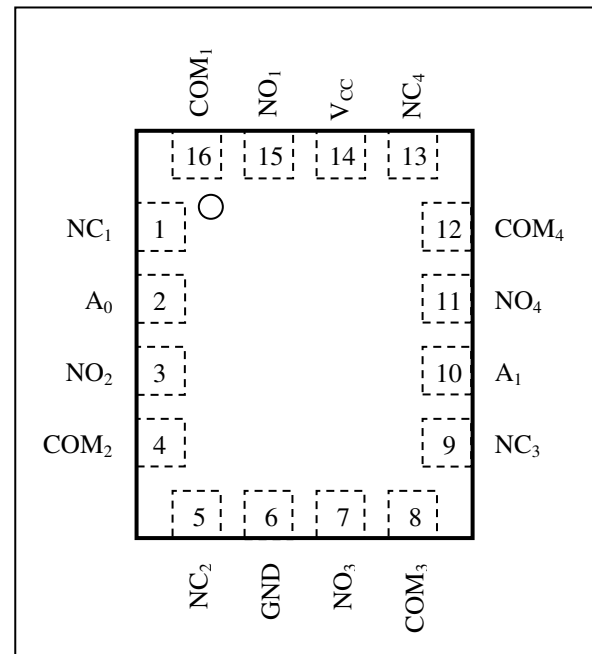

Pin Description

Pin#	Name	Description
4, 8, 12, 16	COM _x	Common Output / Data Port
1, 5, 9, 13	NC _x	Data Port (normally connect)
3, 7, 11, 15	NO _x	Data Port (normally open)
2, 10	A ₀ , A ₁	Logic Input Control
6	GND	Ground
14	VCC	Positive Power Supply

Notes: X = 1, 2, 3, or 4

Maximum Ratings

Storage Temperature	-65°C to +150°C
Ambient Temperature	-40°C to +85°C
ESD(HBM)	4kV for All Pins 8kV for I/O to GND
Supply Voltage V_{CC}	-0.5V to +4.6V
Control Input Voltage (V_{INX})	0 to +5.0V
DC Input Voltage (V_{INPUT})	-0.5V to +4.6V
Continuous Current NO/NC/COM	±400mA
Peak Current NO/NC/COM (Pulse at 1ms 10% duty cycle)	±500mA

Note:

Stresses greater than those listed under MAXIMUM RATINGS may cause permanent damage to the device. This is a stress rating only and functional operation of the device at these or any other conditions above those indicated in the operational sections of this specification is not implied. Exposure to absolute maximum rating conditions for extended periods may affect reliability.

Recommended Operating Conditions

Symbol	Parameter	Conditions	Min.	Typ.	Max.	Unit
V_{CC}	Supply Voltage	-	1.65	-	4.3	V
V_{INX}	Control Input Voltage	-	0	-	4.3	V
V_{INPUT}	Switch Input Voltage	-	-0.3	-	V_{CC}	V
T_A	Operating Temperature	-	-40	25	85	°C
t_r, t_f	Input Rise and Fall Time	Control Input pins $V_{CC} = 2.3V$ to $3.6V$	0	-	10	ns/V

Note: Control input must be held HIGH or LOW; it must not float.

DC Electrical Characteristics

($V_{CC} = 1.65$ to $4.3V$, $GND=0V$, $V_{IH}=+1.6V$, $V_{IL}=+0.4V$, $T_A = -40^{\circ}C$ to $85^{\circ}C$, unless otherwise noted. Typical values are at $3V$ and $+25^{\circ}C$.)

Parameter	Symbol	Test Conditions	Min.	Typ.	Max.	Units	
Analog Signal Range	V_{NO} , V_{NC} , V_{COM}	-	0	-	V_{CC}	V	
On-Resistance	R_{ON}	$I_{COM} = 100mA$, V_{NO} or $V_{NC} = 1V$, Test Circuit 1	$V_{CC} = 2.7V$,	-	2.2	3.6	Ω
			$V_{CC} = 3.0V$,	-	2.0	3	
			$V_{CC} = 4.3V$	-	1.6	2.4	
On-Resistance Match Between Channels	ΔR_{ON}	$I_{COM} = 100mA$, V_{NO} or $V_{NC} = 1V$, Test Circuit 1	$V_{CC} = 3.0V$	-	0.2	-	Ω
			$V_{CC} = 4.3V$	-	0.2	-	
On-Resistance Flatness	R_{ONF}	$I_{COM} = 100mA$, V_{NO} or $V_{NC} = 0 \sim V_{CC}$, Test Circuit 1	$V_{CC} = 3.0V$	-	0.6	-	Ω
			$V_{CC} = 4.3V$	-	0.5	-	
Source Off Leakage Current	$I_{OFF(NO)}$ or $I_{OFF(NC)}$	$V_{CC}=4.3V$, V_{NO} or $V_{NC} = 4.3V/0V$, $V_{COM} =$ $0V/4.3V$	-	-	1	μA	
Channel On Leakage Current	$I_{NC(ON)}$, $I_{NO(ON)}$, I_{COM} (ON)	$V_{CC}=4.3V$, V_{NO} or $V_{NC} = 4.3V/0V$, $V_{COM} =$ $0V/4.3V$ or floating	-	-	1		
Input Logic High	V_{IH}	$V_{CC} = 3.0V$	1.2	-	-	V	
		$V_{CC} = 4.3V$	1.3	-	-		
Input Logic Low	V_{IL}	$V_{CC} = 3.0V$	-	-	0.5		
		$V_{CC} = 4.3V$	-	-	0.6		
IN Input Leakage Current	I_{IN}	$V_{CC} = 4.3V$, $V_{IN}=0 \sim 4.3V$	-	-	+/-1	μA	
Turn-On Time	t_{ON}	$R_L=50\Omega$, $C_L=35pF$, $T_A=25^{\circ}C$, See Test Circuit Figure 2	-	8	-	ns	
Turn-Off Time	t_{OFF}		-	12	-	ns	
Break-Before-Make Delay	t_D	$T_A=25^{\circ}C$, See Test Circuit Figure 3	-	9	-	ns	
NC-NO and COM- NC/NO Off-Isolation	O_{ISO}	$V_{BIAS} = 1.5V$, $V_{IN}=0dBm$, $T_A=25^{\circ}C$, See Test Circuit Figure 4	1MHz	-	-67	-	dB
Channel-to-Channel Crosstalk	X_{TALK}	$V_{BIAS} = 1.5V$, $V_{IN}=0dBm$, $T_A=25^{\circ}C$, See Test Circuit Figure 5	1MHz	-	-100	-	dB
3dB Bandwidth	f_{3dB}	$C_L=5pF$, See Test Circuit Figure 6	-	330	-	MHz	
Total Harmonic Distortion	THD	$V_{CC}=3.0V$, $f=20$ Hz to 20 kHz, $R_L = 32\Omega$, $V_{IN}= 1.0$ VPP	-	0.03	-	%	
Charge Injection Select Input to Common I/O	Q	$V_{IN} = GND$, $R_S = 0$, $C_L = 1nF$, $T_A=25^{\circ}C$, See Test Circuit Figure 7	-	13	-	pC	
Off Capacitance	$C_{NC(OFF)}$	$f=1MHz$, $T_A=25^{\circ}C$, See Test Circuit Figure 8	-	7	-	pF	
	$C_{NO(OFF)}$		-	7	-		
On Capacitance	C_{ON}	$f=1MHz$, $T_A=25^{\circ}C$, See Test Circuit Figure 9	-	15	-		
Power Supply Current	I_{CC}	$V_{CC} = 4.3V$, $V_{IN}=0V$ or V_{CC}	-	-	1	μA	

Test Circuits and Timing Diagrams

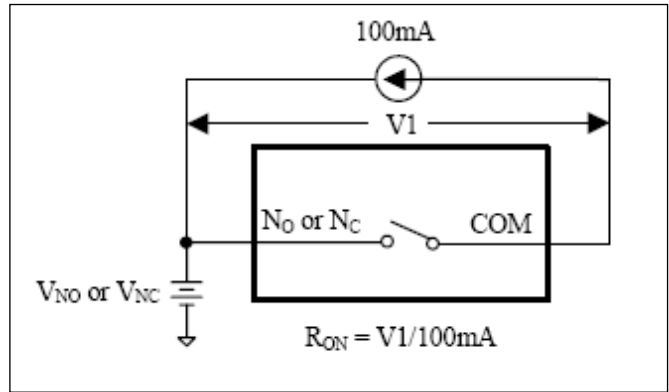

Figure 1. On Resistance

Notes: Unused input (NC or NO) must be grounded.

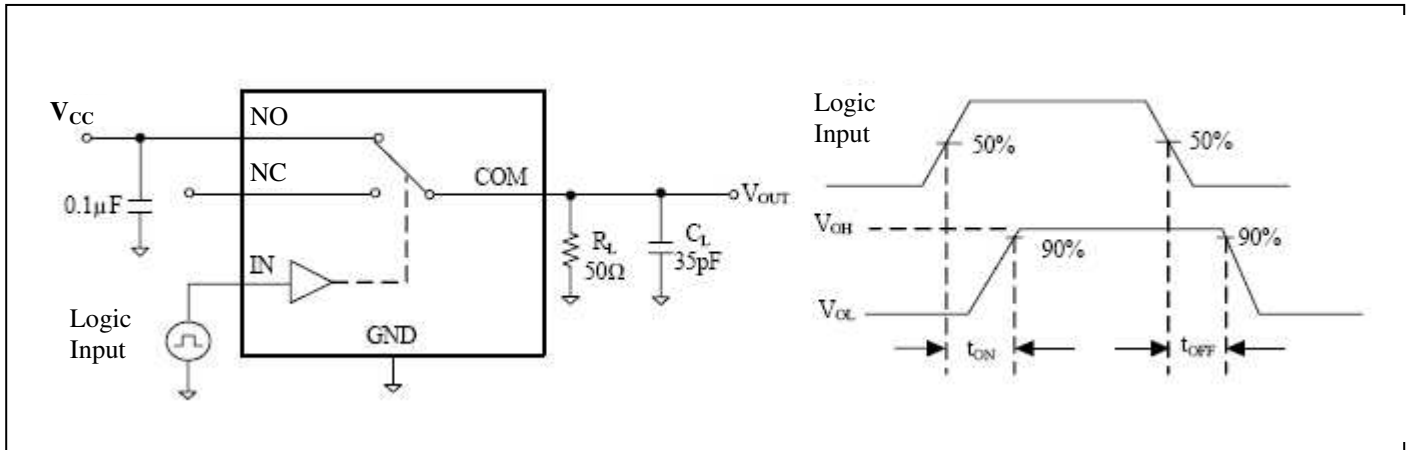

Figure 2. Switching Times

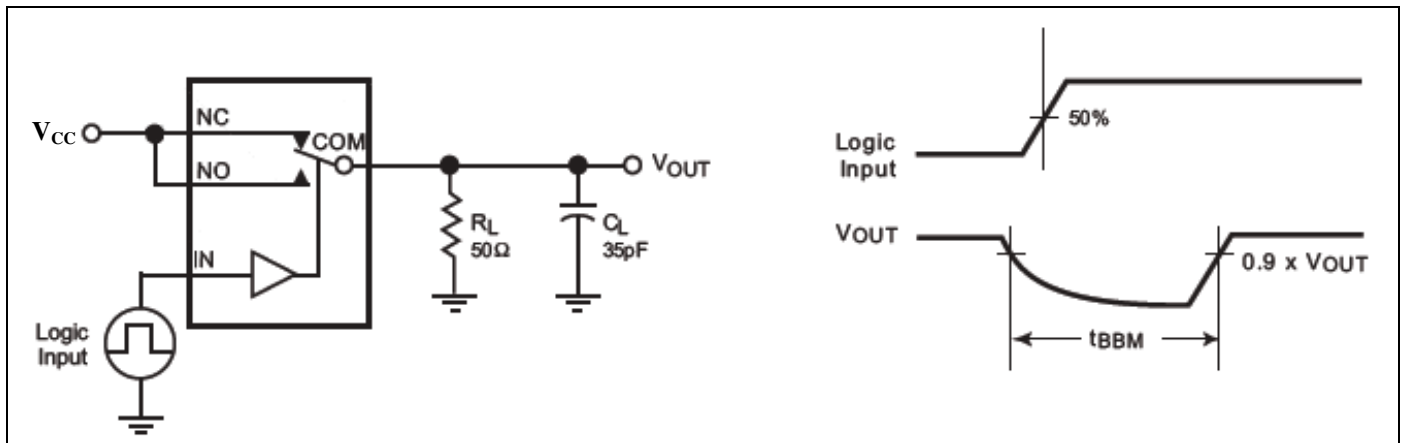

Figure 3. Break Before Make Interval Timing

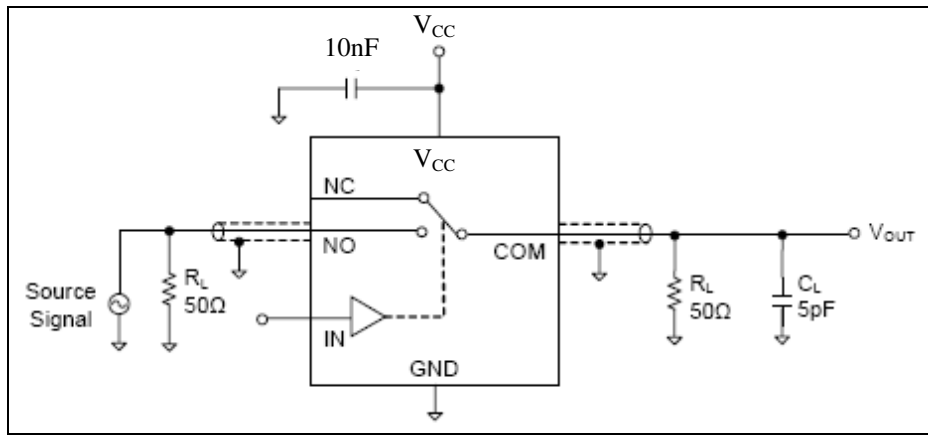

Figure 4. Off Isolation Test

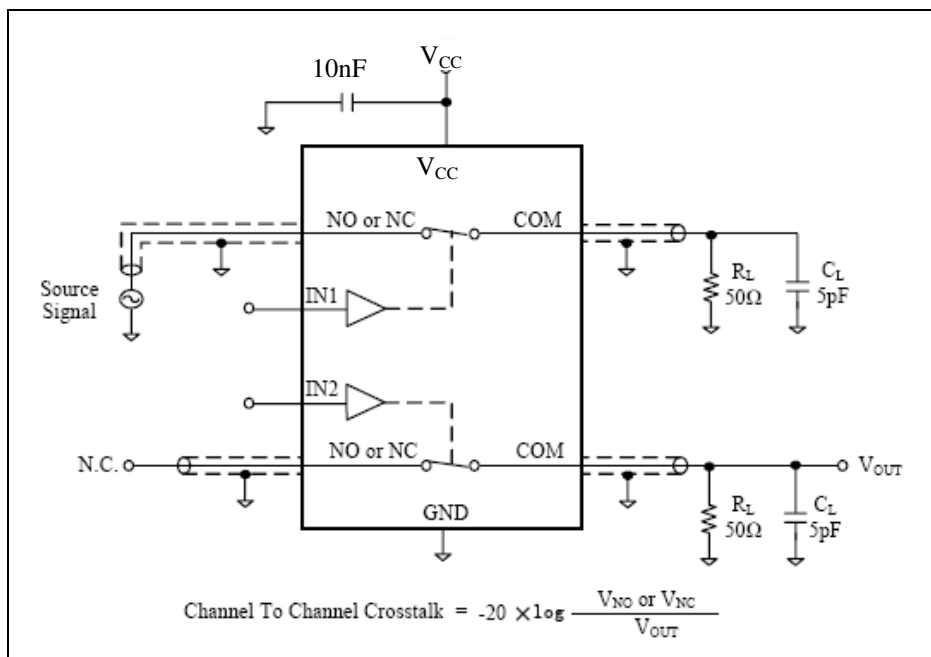

Figure 5. Channel-to-Channel Cross Talk

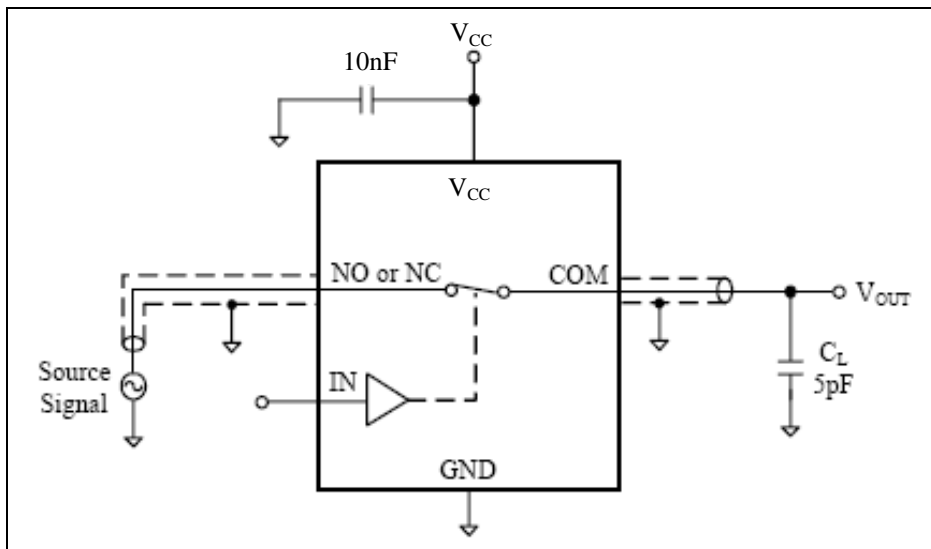

Figure 6. Bandwidth

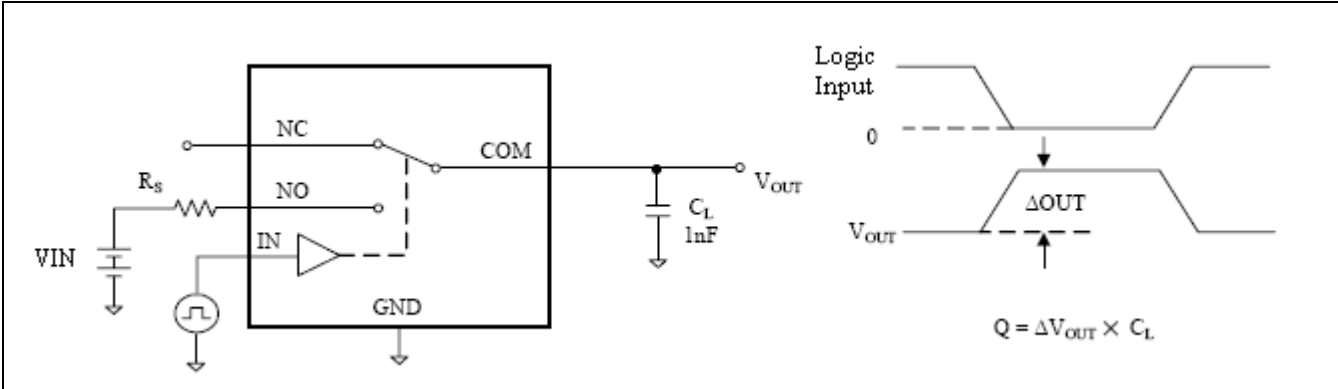

Figure 7. Charge Injection (Q)

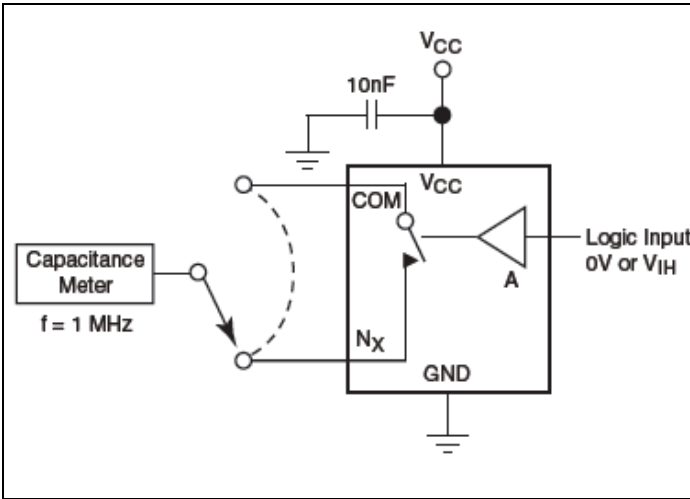

Figure 8. Channel Off Capacitance

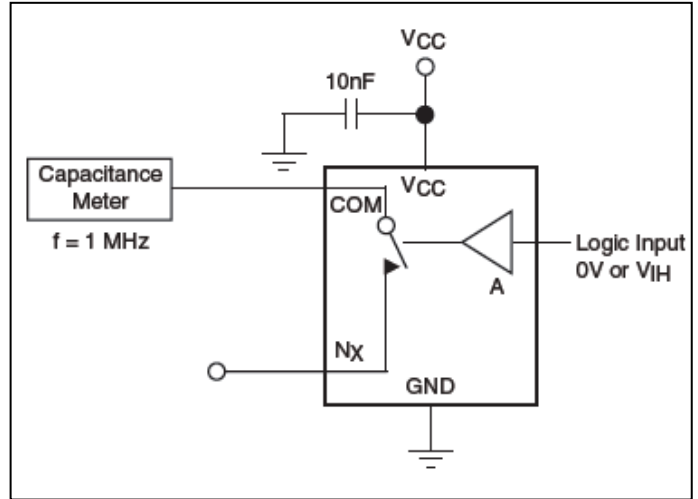

Figure 9. Channel On Capacitance

Part Marking

ZT Package



YW: Year and Workweek

Package Mechanical

UQFN-16 (ZT)

TOP VIEW

BOTTOM VIEW

SIDE VIEW

PKG. DIMENSIONS(MM)		
SYMBOL	Min	Max
A	0.50	0.60
A1	0.00	0.05
A3	0.15 REF	
D	1.75	1.85
E	2.55	2.65
b	0.15	0.25
L	0.30	0.50
L1	0.50 BSC	
e	0.40 BSC	

Note:
1. Ref: JEDEC MO-288B

DATE: 06/18/13

DESCRIPTION: 16-Pin, UQFN, 1.8x2.6	
PACKAGE CODE: ZT (ZT16)	
DOCUMENT CONTROL #: PD-2153	REVISION: --

13-0192

For latest package info.

please check: <http://www.diodes.com/design/support/packaging/pericom-packaging/packaging-mechanicals-and-thermal-characteristics/>

Ordering Information

Part Number	Package Code	Package Description
PI3A3899ZTEX	ZT	16-Pin, 1.8x2.6 (UQFN)

Notes:

- EU Directive 2002/95/EC (RoHS), 2011/65/EU (RoHS 2) & 2015/863/EU (RoHS 3) compliant. All applicable RoHS exemptions applied.
- See <http://www.diodes.com/quality/lead-free/> for more information about Diodes Incorporated's definitions of Halogen- and Antimony-free, "Green" and Lead-free.
- Thermal characteristics can be found on the company web site at www.diodes.com/design/support/packaging/
- E = Pb-free and Green
- X suffix = Tape/Reel

IMPORTANT NOTICE

DIODES INCORPORATED MAKES NO WARRANTY OF ANY KIND, EXPRESS OR IMPLIED, WITH REGARDS TO THIS DOCUMENT, INCLUDING, BUT NOT LIMITED TO, THE IMPLIED WARRANTIES OF MERCHANTABILITY AND FITNESS FOR A PARTICULAR PURPOSE (AND THEIR EQUIVALENTS UNDER THE LAWS OF ANY JURISDICTION).

Diodes Incorporated and its subsidiaries reserve the right to make modifications, enhancements, improvements, corrections or other changes without further notice to this document and any product described herein. Diodes Incorporated does not assume any liability arising out of the application or use of this document or any product described herein; neither does Diodes Incorporated convey any license under its patent or trademark rights, nor the rights of others. Any Customer or user of this document or products described herein in such applications shall assume all risks of such use and will agree to hold Diodes Incorporated and all the companies whose products are represented on Diodes Incorporated website, harmless against all damages.

Diodes Incorporated does not warrant or accept any liability whatsoever in respect of any products purchased through unauthorized sales channel.

Should Customers purchase or use Diodes Incorporated products for any unintended or unauthorized application, Customers shall indemnify and hold Diodes Incorporated and its representatives harmless against all claims, damages, expenses, and attorney fees arising out of, directly or indirectly, any claim of personal injury or death associated with such unintended or unauthorized application.

Products described herein may be covered by one or more United States, international or foreign patents pending. Product names and markings noted herein may also be covered by one or more United States, international or foreign trademarks.

This document is written in English but may be translated into multiple languages for reference. Only the English version of this document is the final and determinative format released by Diodes Incorporated.

LIFE SUPPORT

Diodes Incorporated products are specifically not authorized for use as critical components in life support devices or systems without the express written approval of the Chief Executive Officer of Diodes Incorporated. As used herein:

A. Life support devices or systems are devices or systems which:

1. are intended to implant into the body, or
2. support or sustain life and whose failure to perform when properly used in accordance with instructions for use provided in the labeling can be reasonably expected to result in significant injury to the user.

B. A critical component is any component in a life support device or system whose failure to perform can be reasonably expected to cause the failure of the life support device or to affect its safety or effectiveness.

Customers represent that they have all necessary expertise in the safety and regulatory ramifications of their life support devices or systems, and acknowledge and agree that they are solely responsible for all legal, regulatory and safety-related requirements concerning their products and any use of Diodes Incorporated products in such safety-critical, life support devices or systems, notwithstanding any devices- or systems-related information or support that may be provided by Diodes Incorporated. Further, Customers must fully indemnify Diodes Incorporated and its representatives against any damages arising out of the use of Diodes Incorporated products in such safety-critical, life support devices or systems.

Copyright © 2016, Diodes Incorporated
www.diodes.com