



Chipsmall Limited consists of a professional team with an average of over 10 year of expertise in the distribution of electronic components. Based in Hongkong, we have already established firm and mutual-benefit business relationships with customers from,Europe,America and south Asia,supplying obsolete and hard-to-find components to meet their specific needs.

With the principle of “Quality Parts,Customers Priority,Honest Operation,and Considerate Service”,our business mainly focus on the distribution of electronic components. Line cards we deal with include Microchip,ALPS,ROHM,Xilinx,Pulse,ON,Everlight and Freescale. Main products comprise IC,Modules,Potentiometer,IC Socket,Relay,Connector.Our parts cover such applications as commercial,industrial, and automotives areas.

We are looking forward to setting up business relationship with you and hope to provide you with the best service and solution. Let us make a better world for our industry!



## Contact us

Tel: +86-755-8981 8866 Fax: +86-755-8427 6832

Email & Skype: info@chipsmall.com Web: www.chipsmall.com

Address: A1208, Overseas Decoration Building, #122 Zhenhua RD., Futian, Shenzhen, China



# PI3DBS16212

## 3.3V, 1-20Gbps 1-Lane 2:1 Mux/De-Mux Switch

### Features

- 2 Differential Channel, 2:1 Mux/DeMux
- Up to 20 Gbps for applications including USB3.0, USB3.1, 10GE, Thunderbolt 3, and SAS3.0
- Bi-directional operation
- 3dB bandwidth: 13 GHz
- Low Bit-to-Bit Skew, 3ps typ
- Low channel-to-channel skew, 10ps typ
- Low insertion loss: -1.3dB@5 GHz, -1.3dB@8 GHz, -2dB@10 GHz
- Return loss: -21dB@5 GHz, -13dB@8 GHz, -9dB@10 GHz
- Low power consumption - 300µA typ
- Supply Voltage 3.3V
- Industrial Temperature Range: -40oC to 85oC
- Packaging (Pb-free & Green):
  - 20-contact, TQFN(ZBB20), 2.5x4.5mm
  - 18 contact, X2QFN (XUA18), 2x2mm

### Block Diagram

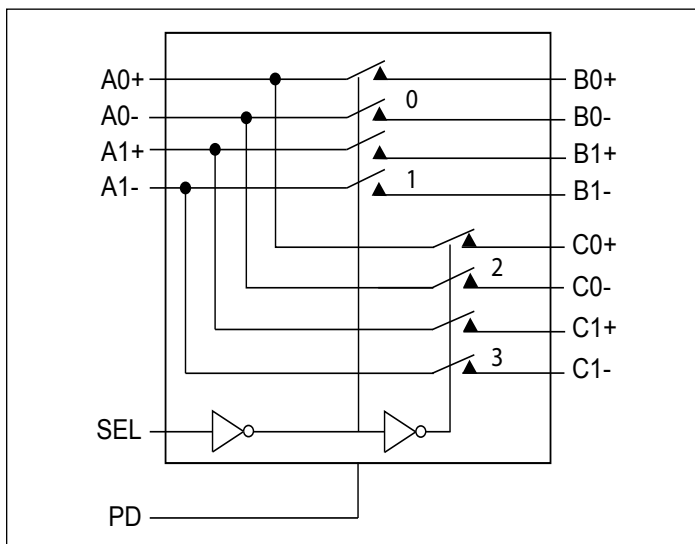

### Description

The PI3DBS16212 is an 4 to 2 differential channel multiplexer/de-multiplexer switch. This solution can switch multiple signal types up to data rate of 20Gbps. Using a unique design technique, Pericom has been able to minimize the impedance of the switch such that the attenuation observed through the switch is minimal. The unique design technique also offers a layout targeted for USB3.0, USB3.1, 10GE, Thunderbolt 3, and SAS3.0 signals, which minimizes the channel to channel skew as well as channel to channel crosstalk as required by high speed signals.

### Applications

- Routing high speed differential signals such as USB3.1 Gen 2, SAS3, PCIe4, TB3

### Ordering Information

| Part Number      | Package | Description                                    |
|------------------|---------|--|
| PI3DBS16212ZBBEX | ZBB     | 20-Contact, Very Thin Quad Flat No-Lead (TQFN) |
| PI3DBS16212XUAEX | XUA     | 18-Contact, 2x2mm (X2QFN)                      |

Notes:

1. EU Directive 2002/95/EC (RoHS), 2011/65/EU (RoHS 2) & 2015/863/EU (RoHS 3) compliant. All applicable RoHS exemptions applied.
2. See <http://www.diodes.com/quality/lead-free/> for more information about Diodes Incorporated's definitions of Halogen- and Antimony-free, "Green" and Lead-free. Thermal characteristics can be found on the company web site at [www.diodes.com/design/support/packaging/](http://www.diodes.com/design/support/packaging/)
3. E = Pb-free and Green
4. X suffix = Tape/Reel