



Chipsmall Limited consists of a professional team with an average of over 10 year of expertise in the distribution of electronic components. Based in Hongkong, we have already established firm and mutual-benefit business relationships with customers from,Europe,America and south Asia,supplying obsolete and hard-to-find components to meet their specific needs.

With the principle of “Quality Parts,Customers Priority,Honest Operation,and Considerate Service”,our business mainly focus on the distribution of electronic components. Line cards we deal with include Microchip,ALPS,ROHM,Xilinx,Pulse,ON,Everlight and Freescale. Main products comprise IC,Modules,Potentiometer,IC Socket,Relay,Connector.Our parts cover such applications as commercial,industrial, and automotives areas.

We are looking forward to setting up business relationship with you and hope to provide you with the best service and solution. Let us make a better world for our industry!



Contact us

Tel: +86-755-8981 8866 Fax: +86-755-8427 6832

Email & Skype: info@chipsmall.com Web: www.chipsmall.com

Address: A1208, Overseas Decoration Building, #122 Zhenhua RD., Futian, Shenzhen, China



Features

- USB 3.0 compatible
- Full compliancy to USB 3.0 Super Speed standard
- One 5.0Gbps differential signal pairs
- Adjustable Receiver Equalization
- 100Ω Differential CML I/O's
- Pin Configured Output Emphasis Control
- Input signal level detect and squelch function
- Automatic Receiver Detect
- Host Mode Capable
- Low Power : 165mW
- Auto "Slumber" mode for adaptive power management
- Single Supply Voltage: 3.3V
- Packaging: 8-Pin TDFN 2 x 2 mm

Description

Pericom Semiconductor's PI3EQX501B is a low power, high performance 5.0 Gbps signal ReDriver™ designed specifically for the USB 3.0 protocol. The device provides programmable equalization and De-Emphasis to optimize performance over a variety of physical mediums by reducing Inter-Symbol Interference.

PI3EQX501B supports one 100Ω Differential CML data I/O's between the Protocol ASIC to a switch fabric, over cable, or to extend the signals across other distant data pathways on the user's platform. The integrated equalization circuitry provides flexibility with signal integrity of the signal before the ReDriver. A low-level input signal detection and output squelch function is provided. The channels' input signal level determines whether the output is active.

The PI3EQX501B also includes a receiver detect function. The receiver detection loop will be active again if the corresponding channel's signal detector is idle for longer than 7.3mS. The channel will then move to Unplug Mode if load not detected, or it will return to Low Power Mode (Slumber Mode) due to inactivity.

Pin Diagram (Top Side View)

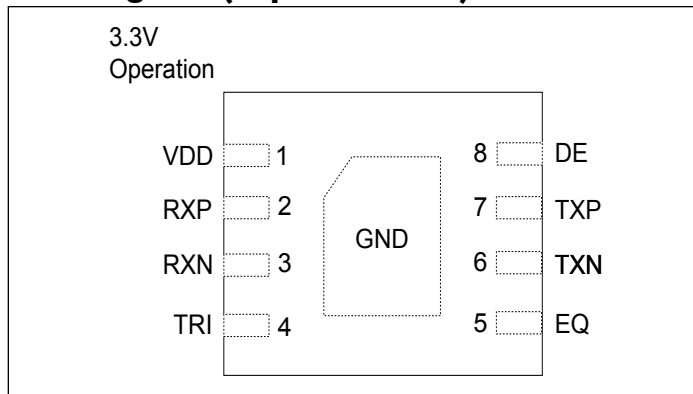

Block Diagram

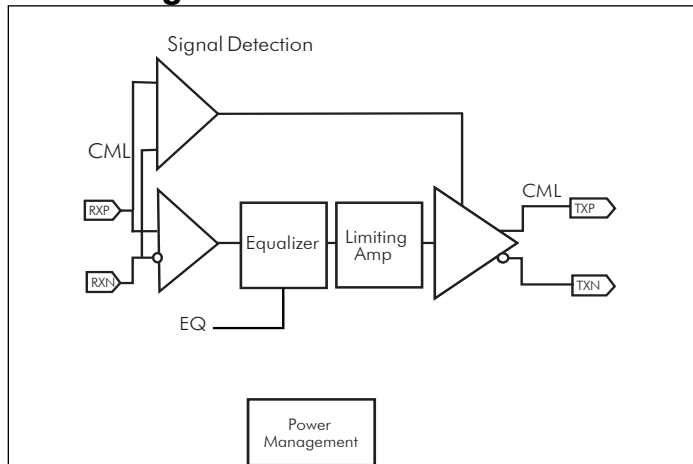
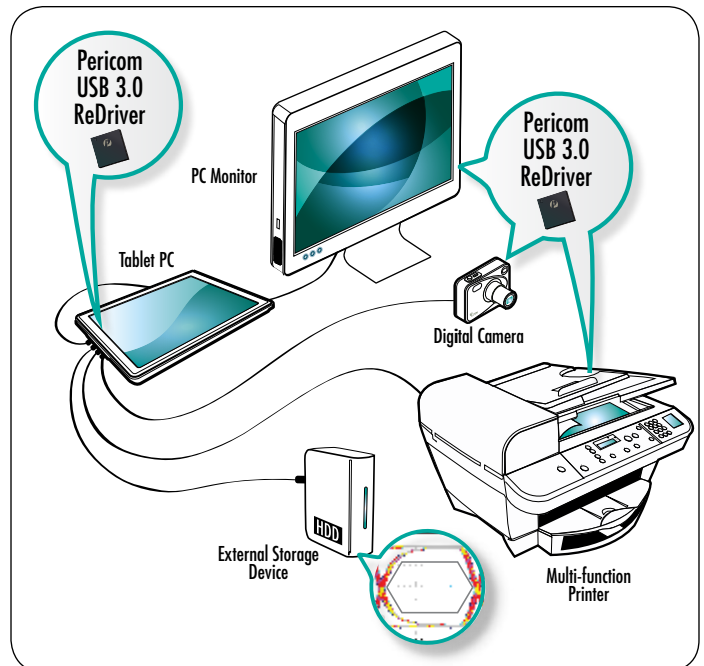

Figure 1



Pin Description

Pin #	Pin Name	Type	Description
1	VDD	Power	3.3V power supply
2,3	RXP, RXN	Input	CML input channels. With Selectable input termination between 50Ω to internal Vbias or 60kΩ to ground.
4	TRI	Input	Set the state of chip; With internal 200kΩ pull-down resistor “High” means NO receiver termination detection and for debug mode. “Low” means normal operation mode with receiver termination detection.
5	EQ	Input	Set the equalization of the channels. Tri-level input pin. With internal 100kΩ pull-up resistor and 100kΩ pull-down resistor.
7, 6	TXP, TXN	Output	Selectable output termination between 50Ω to internal Vbias or 2kΩ to internal Vbias.
8	DE	Input	Set de-emphasis of output CML buffer. Tri-level input pin. With internal 100kΩ pull-up resistor and 100kΩ pull-down resistor.
Center Pad	GND	GND	Supply Ground.

Power Management

Notebooks, netbooks, tablets and other power sensitive consumer devices require judicious use of power in order to maximize battery life. In order to minimize the power consumption of our devices, Pericom has added an additional adaptive power management feature. When a signal detector is idle for longer than 1.3ms, the channel will move to low power mode.

In the low power mode, the signal detector will still be monitoring the input channel. If a channel is in low power mode and the input signal is detected, it will wake-up immediately. If a channel is in low power mode and the signal detector is idle longer than 6ms, the receiver detection loop will be active again. If load is not detected, then the Channel will move to Device Unplug Mode and monitor the load continuously. If load is detected, it will return to Low Power Mode and receiver detection will be active again per 6ms.

Configuration Table

Mode	Input R	Output R
Unplug mode	60kΩ to GND	2kΩ to V _{BIAS}
Slumber mode	50Ω to V _{BIAS}	2kΩ to V _{BIAS}
Active mode	50Ω to V _{BIAS}	50Ω to V _{BIAS}

Mode Adjustment

Equalization Setting:

EQ is the selection pin for the equalization.

Equalizer setting	
EQ	@ 2.5GHz
0	3 dB
open	6dB (Default)
1	9dB

De-emphasis Setting:

DE is the selection pin for the de-emphasis.

Output de-emphasis setting	
DE	De-emphasis
0	0 dB
open	-3.5 dB (default)
1	-6 dB

Maximum Ratings

(Above which useful life may be impaired. For user guidelines, not tested.)

Storage Temperature.....	-65°C to +150°C
Supply Voltage to Ground Potential.....	-0.5V to +4.6V
DC SIG Voltage.....	-0.5V to V _{DD} +0.5V
Current Output	-25mA to +25mA
Power Dissipation Continuous.....	1.0W
Operating Temperature.....	-40°C to +85°C
ESD, Human Body Model.....	-8kv to +8kV
ESD, Machine Model.....	-200V to +200V

Note:

Stresses greater than those listed under MAXIMUM RATINGS may cause permanent damage to the device. This is a stress rating only and functional operation of the device at these or any other conditions above those indicated in the operational sections of this specification is not implied. Exposure to absolute maximum rating conditions for extended periods may affect reliability.

RECOMMENDED OPERATING CONDITIONS

Symbol	Parameter	Conditions	Min.	Typ.	Max.	Units
DEVICE PARAMETERS						
maximum data rate					5	Gbps
t _{ENB}	Slumber mode exist time	LFPS signal		20		ns
t _{DIS}	Slumber mode entry time	Electrical idle		1.3		ms
CONTROL LOGIC						
I _{IH}	Input High Current				50	uA
I _{IL}	Input LOW Current		-50			
Tri-level Control Pins(Pins: 5, 8)						
V _{IH}	Input High Voltage		0.8V _{DD}			V
V _{IL}	Input Low Voltage				0.2V _{DD}	
LVC MOS Control Pins (Pin: 4)						
V _{IH}	Input High Voltage		0.65V _{DD}			V
V _{IL}	Input Low Voltage				0.35V _{DD}	

AC/DC Electrical Characteristics

3.3V Power Supply Characteristics						
Symbol	Parameter	Conditions	Min.	Typ.	Max.	Units
V _{DD}	Power Supply Voltage	TRI=0	3.0		3.6	V
P _{SLUMBER33}	Supply Power Slumber	Device Plugged, No Input Signal		28	35	mW
P _{DEVICE_UNPLUG}	Supply Power Device Unplug	TRI = 0, Device Unplugged, No Input Signal		7.3		
P _{ACTIVE33}	Supply Power Active	V _{RX-DIFF-P} ≥ V _{TH-SD} , DE=1, Device Plugged		192		
I _{DD-SLUMBER33}	Supply Current Slumber	TRI=0, Device Plugged, No Input Signal		8.3	9.5	mA
I _{DD-DEVICE_UNPLUG}	Supply Current Device Unplug	TRI = 0, Device Unplugged, No Input Signal		2.2		
I _{DD-ACTIVE33}	Supply Current Active	V _{RX-DIFF-P} ≥ V _{TH-SD} , DE=1, Device Plugged		58	67	

AC/DC Electrical Characteristics (Continued..)

Symbol	Parameter	Conditions	Min.	Typ.	Max.	Units
Receiver AC/DC						
$V_{RX-DIFFP-P}$	Differential Peak-to-Peak Input Voltage	AC coupled differential RX peak to peak signal	175		1200	mVppd
V_{RX-C}	Common Mode Voltage			1		V
V_{cm_ac}	RX AC Common Mode Voltage	Measured at Rx pins with termination enabled			150	mV
Z_{DC_RX}	DC common mode impedance		18	26	30	Ω
Z_{diff_RX}	DC differential input impedance		72	80	120	
$Z_{RX_HIGH_IMP+}$	DC Input high impedance	Device in unplug mode RX termination measured with respect to AC GND over 500mV max		67		k Ω
$RL_{RX-DIFF}$	Differential return loss	50 MHz-1.25GHz		23		dB
		1.25 GH-2.5 GHz		13		
RL_{RX-CM}	Common mode return loss	50 MHz-2.5 GHz		8		dB
TH-SD	Signal detect Threshold		65		175	mVppd
Transmitter Output AC/DC (100Ω differential)¹						
$V_{TX-DIFFP-P}$	Differential Peak-to-peak Output Voltage	$V_{TX-DIFFP-P} = 2 * V_{TX-D+} - V_{TX-D-} $	400		1200	mVppd
$V_{TX-LFPS}$	LFPS Differential Peak-to-peak Output Voltage		800			
V_{TX-C}	Common-Mode Voltage	$ V_{TX-D+} + V_{TX-D-} /2$	0.5		1.2	V
V_{cm_ac}	TX AC common mode voltage				100	mVpp
DE		DE = 0		0		dB
		DE = NC	-3.0	-3.5	-4.0	
		DE = 1		-6.0		
Z_{diff_TX}	DC differential impedance		72	90	120	Ω
Z_{CM_TX}	DC common mode impedance		18	23	30	
RL_{diff_TX}	Differential return loss	f = 50MHz-1.25 GHz		12		dB
		f = 1.25 GHz-2.5 GHz		8		
RL_{CM_TX}	Common mode return loss	f = 50 MHz-1.25GHz		10		dB
		f = 1.25GHz-2.5GHz		4.5		
I_{TX_SC}	TX short circuit current	TX \pm shorted to GND		26		mA
V	Transmitter DC common-mode voltage V			0.85		V
$V_{TX_CM_AC_Active}$	TX AC common mode voltage active			30	100	mVpp

AC/DC Electrical Characteristics (Continued..)

Symbol	Parameter	Conditions	Min.	Typ.	Max.	Units
V _{detect}	Voltage change to allow receiver detect	Positive voltage to sense receiver termination			600	mV
t _{R,F}	Output rise/fall time	20%-80% of differential voltage measured 1" from the output pin		90		ps
t _{RF_MM}	Output rise/fall time mismatch	20%-80% of differential voltage measured 1" from the output pin		1.5	20	
T _{diff_LH} , T _{diff_HL}	Differential propagation delay	Propagation delay between 50% level at input and output		305		ps
Jitter Profile						
T _{TX-EYE} ⁽¹⁾⁽²⁾	Total jitter(Tj)	with 36 inch of input FR4 trace		0.2	0.5	UI ⁽³⁾
DJ _{TX} ⁽²⁾	Deterministic jitter(Dj)			0.1	0.3	
RJ _{TX} ⁽²⁾⁽⁴⁾	Random jitter(Rj)			0.09	0.2	

Note:

- 1.Includes RJ at 10⁻¹² BER
- 2.Deterministic jitter measured with PRBS31 pattern, Random jitter measured with 1010 pattern VID=1000mVpp, 5Gbps,
- 3.UI = 200ps
- 4.Rj calculated as 14.069 times the RMS random jitter for 10⁻¹² BER

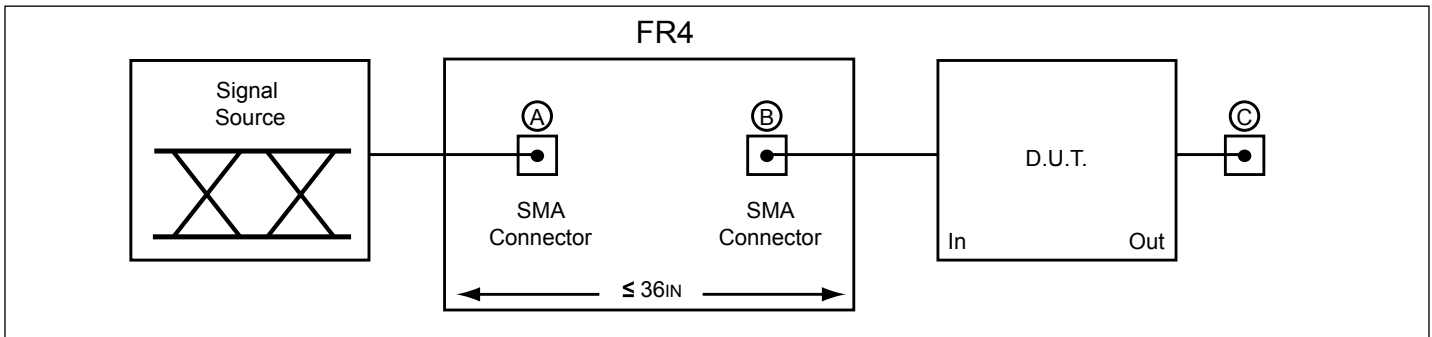

Test Condition Referenced in the Electrical Characteristic Table

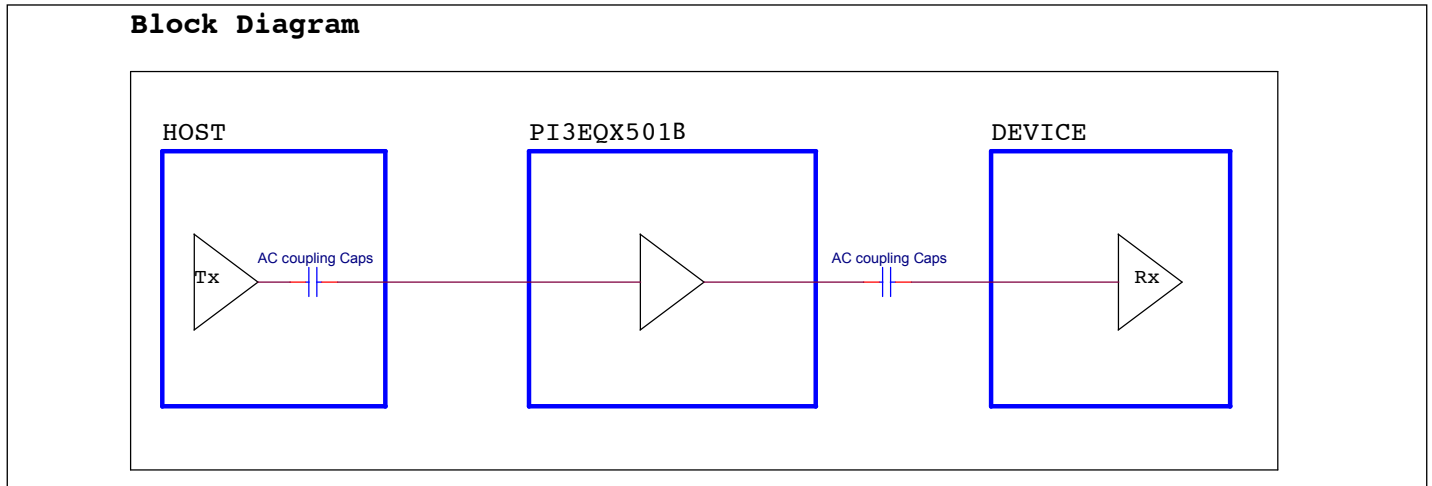

PI3EQX501B Application Schematics

Packaging Mechanical: 8-contact TDFN (ZA)

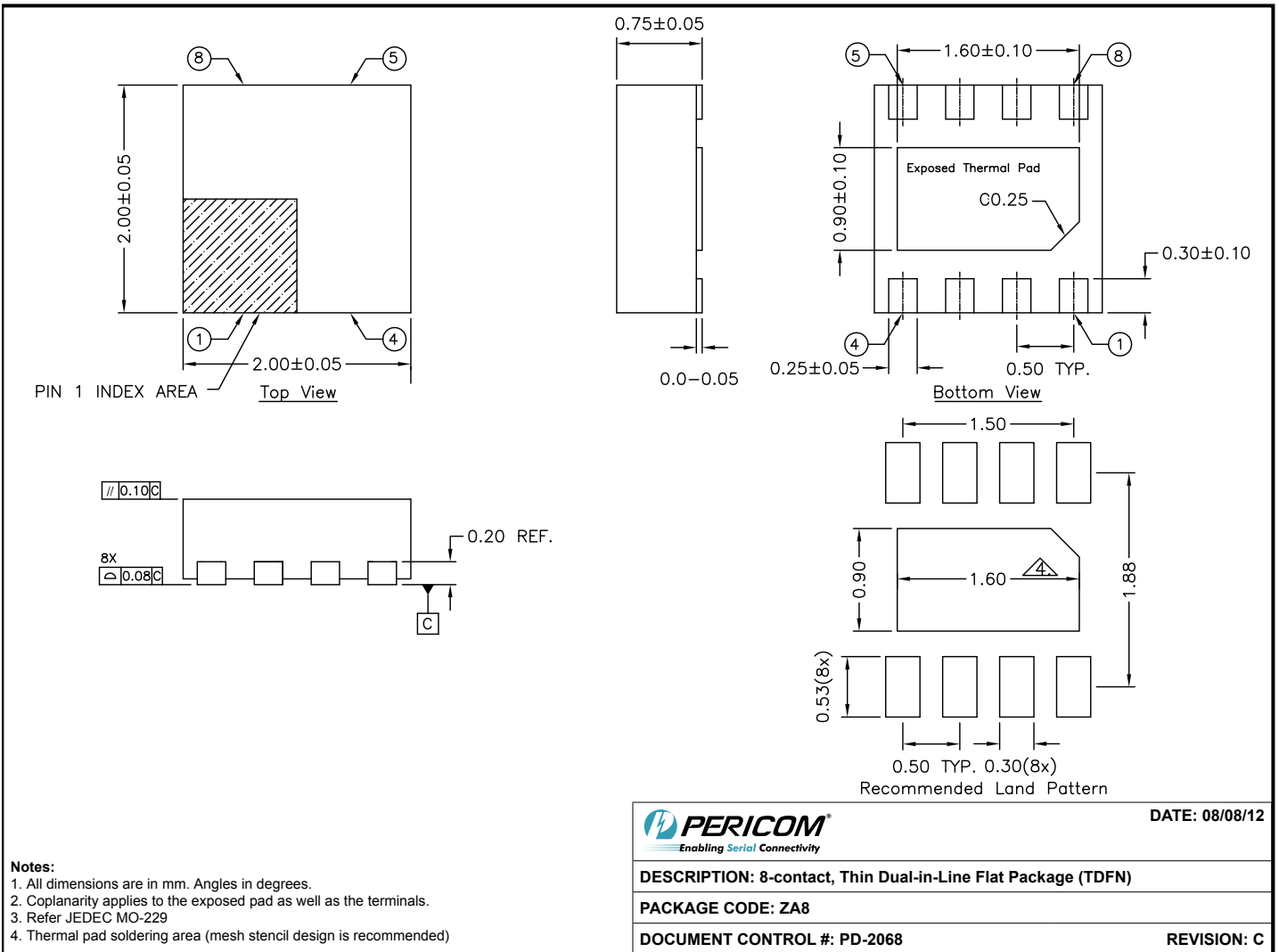

13-0126

Ordering Information

Ordering Number	Package Code	Package Description
PI3EQX501BZAE	ZA	Pb-Free and Green 8-pin

Notes:

- Thermal characteristics can be found on the company web site at www.pericom.com/packaging/
- E = Pb-free and Green
- X suffix = Tape/Reel