



Chipsmall Limited consists of a professional team with an average of over 10 year of expertise in the distribution of electronic components. Based in Hongkong, we have already established firm and mutual-benefit business relationships with customers from,Europe,America and south Asia,supplying obsolete and hard-to-find components to meet their specific needs.

With the principle of “Quality Parts,Customers Priority,Honest Operation,and Considerate Service”,our business mainly focus on the distribution of electronic components. Line cards we deal with include Microchip,ALPS,ROHM,Xilinx,Pulse,ON,Everlight and Freescale. Main products comprise IC,Modules,Potentiometer,IC Socket,Relay,Connector.Our parts cover such applications as commercial,industrial, and automotives areas.

We are looking forward to setting up business relationship with you and hope to provide you with the best service and solution. Let us make a better world for our industry!



Contact us

Tel: +86-755-8981 8866 Fax: +86-755-8427 6832

Email & Skype: info@chipsmall.com Web: www.chipsmall.com

Address: A1208, Overseas Decoration Building, #122 Zhenhua RD., Futian, Shenzhen, China



PI3EQX6801

6.5Gbps, 1-port, 1.5V/3.3V SATA/SAS ReDriver with Analog/Digital Configuration

Description

Diodes Incorporated PI3EQX6801 is a low power, 1.5V/3.3V, 6.5Gbps, SATA/SAS signal ReDriver™. The device provides programmable equalization, to optimize performance over a variety of physical mediums by reducing Inter-Symbol Interference.

PI3EQX6801 supports two 100Ω Differential CML data I/O's between the Protocol ASIC to a switch fabric, across a backplane, or to extend the signals across other distant data pathways on the user's platform.

The integrated equalization circuitry provides flexibility with signal integrity of the signal before the ReDriver.

A low-level input signal detection and output squelch function is provided for each channel. Each channel operates fully independently. When the channels are enabled ($x_EN\# = 0$) and operating, that channels input signal level (on $xI+/-$) determines whether the output is active. If the input signal level of the channel falls below the active threshold level (V_{th-}) then the outputs are driven to the common mode voltage.

Each lane can be powered-down if $x_EN\# = 1$, and when $A_EN\#$ and $B_EN\#$ are both high, the device enters a low power standby mode.

Features

- Two 6.5Gbps differential channels
- Output swing up to 1.2V pk-to-pk
- SAS, SATA fully supported
- Adjustable Receiver Equalization - 0 to 16 dB
- 100Ω Differential CML I/O's
- Continuous step output swing adjustment
- Continuous step output pre-emphasis control
- Input signal level detect and squelch for each channel
- OOB fully supported
- Auto HDD Rate Detection for out swing/emphasis setting
- Supply Voltage: 1.5V or 3.3V
- Low Power, 162mW @ 1.5V (600 mV Swing)
- Stand-by Mode – Power Down State: Current < 56 μA
- HDD unplug power: 1.5mW
- Auto Slumber Mode power: 22.5mW typical
- Industrial Temperature Range -40 to 85°C
- Packaging: 20-contact TQFN (4x4mm)

Application Diagram

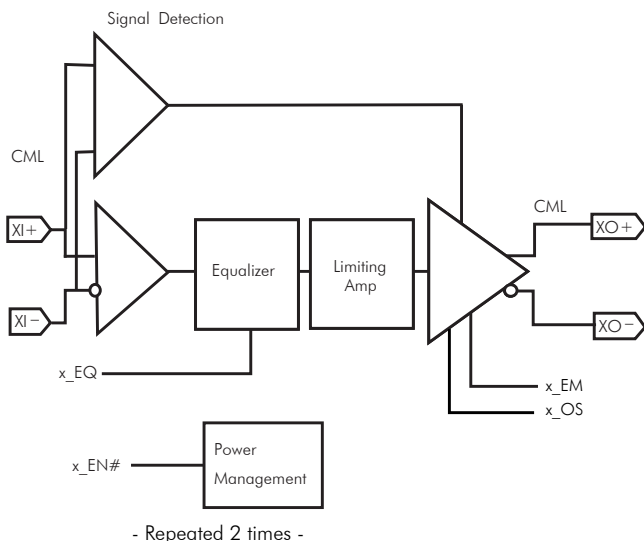

Application

SATA3.0/SAS2.0 6Gbps 4-Port ReDriver in Storage Array Application

