



Chipsmall Limited consists of a professional team with an average of over 10 year of expertise in the distribution of electronic components. Based in Hongkong, we have already established firm and mutual-benefit business relationships with customers from,Europe,America and south Asia,supplying obsolete and hard-to-find components to meet their specific needs.

With the principle of “Quality Parts,Customers Priority,Honest Operation,and Considerate Service”,our business mainly focus on the distribution of electronic components. Line cards we deal with include Microchip,ALPS,ROHM,Xilinx,Pulse,ON,Everlight and Freescale. Main products comprise IC,Modules,Potentiometer,IC Socket,Relay,Connector.Our parts cover such applications as commercial,industrial, and automotives areas.

We are looking forward to setting up business relationship with you and hope to provide you with the best service and solution. Let us make a better world for our industry!



Contact us

Tel: +86-755-8981 8866 Fax: +86-755-8427 6832

Email & Skype: info@chipsmall.com Web: www.chipsmall.com

Address: A1208, Overseas Decoration Building, #122 Zhenhua RD., Futian, Shenzhen, China



5.0 Gbps, 2-port, USB 3.0 ReDriver™ with Digital Configuration

Features

- USB 3.0 compatible
- Four 5.0 Gbps differential signal pairs
- Adjustable Receiver Equalization
- 100Ω Differential CML I/O's
- Pin Configured Output Emphasis Control
- Input signal level detect and squelch for each channel
- Automatic Receiver Detect with digital enable/disable
- Low Power ~680mW
- Auto "Slumber" mode for adaptive power management
- Stand-by Mode – Power Down State
- Single Supply Voltage: 3.3V
- Packaging: 42-Contact TQFN (3.5x9mm)

Pin Diagram (Top Side View)

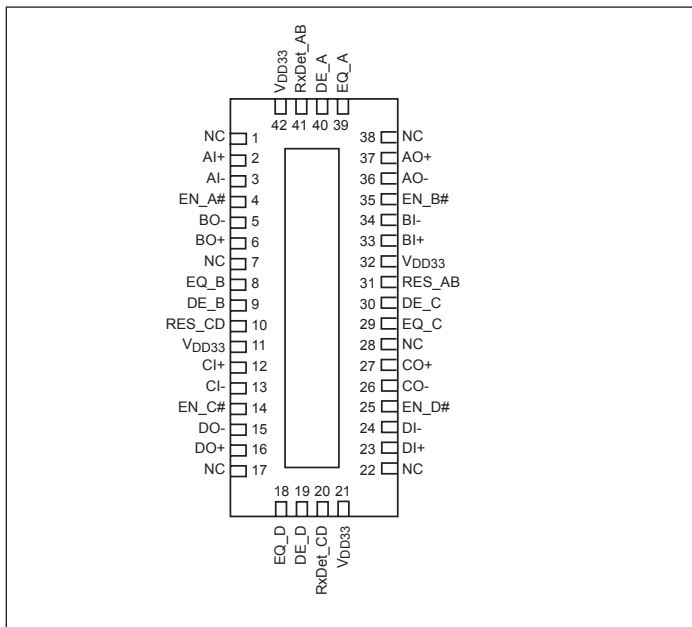
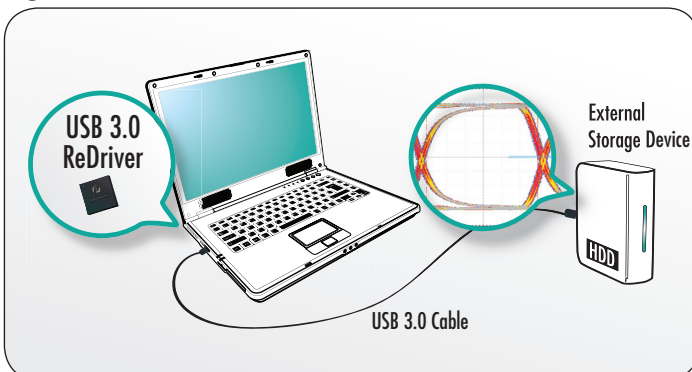

Figure 1



Description

Pericom Semiconductor's PI3EQX7742ST is a low power, high performance 5.0 Gbps signal ReDriver™ designed specifically for the USB 3.0 protocol. The device provides programmable equalization, De-Emphasis, and input threshold controls to optimize performance over a variety of physical mediums by reducing Inter-Symbol Interference. PI3EQX7742ST supports four 100Ω Differential CML data I/O's between the Protocol ASIC to a switch fabric, over cable, or to extend the signals across other distant data pathways on the user's platform.

The integrated equalization circuitry provides flexibility with signal integrity of the signal before the ReDriver. A low-level input signal detection and output squelch function is provided for each channel.

Each channel operates fully independently. When the channels are enabled $EN_x\# = 0$ and operating, that channels' input signal level (on $xI+/-$) determines whether the output is active.

If the input signal level of the channel falls below the active threshold level (V_{th-}) then the outputs are driven to the common mode voltage. In addition to signal conditioning, when $EN_x\# = 1$, the device enters a low power standby mode. The PI3EQX7742ST also includes a fully programmable receiver detect function. When the RxDet pin is pulled high, automatic receiver detection will be active. The device will then move to power down due to inactivity.

Block Diagram

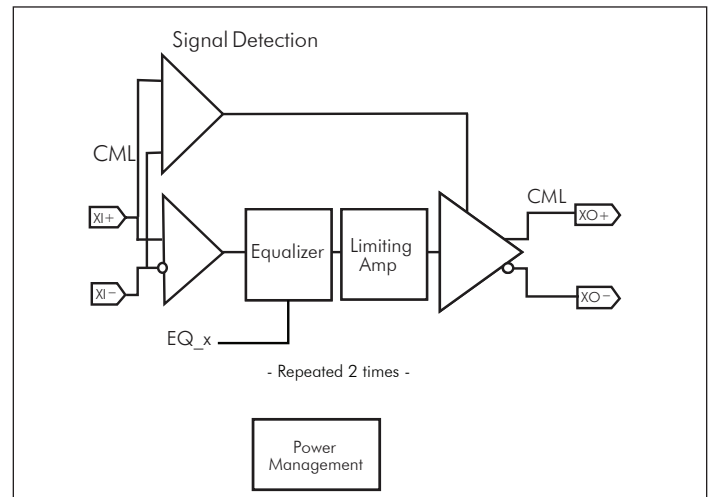

Pin Description

Pin #	Pin Name	Type	Description
1, 7, 17, 22, 28, 38	NC	NC	No Connect
2, 3	AI+, AI-	Input	CML input channels. With Selectable input termination between 50Ω to internal V _{BIAS} and Hi-Z.
5, 6	BO-, BO+	Output	Selectable output termination between 50Ω to internal V _{bias} and 2kΩ to internal V _{bias} , and Hi-Z.
12, 13	CI+, CI-	Input	CML input channels. With Selectable input termination between 50Ω to internal V _{BIAS} and Hi-Z.
15, 16	DO-, DO+	Output	Selectable output termination between 50Ω to internal V _{bias} and 2kΩ to internal V _{bias} , and Hi-Z.
23, 24	DI+, DI-	Input	CML input channels. With Selectable input termination between 50Ω to internal V _{BIAS} and Hi-Z.
26, 27	CO-, CO+	Output	Selectable output termination between 50Ω to internal V _{bias} and 2kΩ to internal V _{bias} , and Hi-Z.
33, 34	BI+, BI-	Input	CML input channels. With Selectable input termination between 50Ω to internal V _{BIAS} and Hi-Z.
36, 37	AO-, AO+	Output	Selectable output termination between 50Ω to internal V _{bias} and 2kΩ to internal V _{bias} , and Hi-Z.
11, 21, 32, 42	VDD33	Power	3.3V Voltage Supply
39, 8, 18, 29	EQ_A, EQ_B, EQ_D, EQ_C	Input	Equalization Adjustment. Tri-level input pin. When set to "high", the pin becomes logic "1"; when set to "open", the pin becomes "open"; when set to "low", the pin becomes logic "0". Please refer to Mode Adjustment on page 3.
40, 9, 19, 30	DE_A, DE_B, DE_D, DE_C	Input	Set the de-emphasis of the output CML buffer. Tri-level input pin. When set to "high", the pin becomes logic "1"; when set to "open", the pin becomes "open"; when set to "low", the pin becomes logic "0". Please refer to Mode Adjustment on page 3.
10, 31	RES_CD, RES_AB	Input	Tie RES Pins high for normal operation. With internal 200kΩ pull-up resistor.
4, 14, 25, 35	EN_A#, EN_C#, EN_D#, EN_B#	Input	Channel Enable. "Low" = Channel is in normal operation. "High" = Channel is in power down mode. With internal 200kΩ pull-down resistor.
20, 41	RXDET_CD, RXDET_AB	Input	Set the state of receiver detection of two channels. "Low" means no receiver detection and "high" means the receiver detection is active. With internal 200kΩ pull-up resistor.
Center Pad	GND	GND	Supply Ground.

Adaptive Auto Power Down or "Slumber" Mode

Notebooks, netbooks, and other power sensitive consumer devices require judicious use of power in order to maximize battery life. In order to minimize the power consumption of our devices, Pericom has added an additional adaptive auto power down feature. When a signal detector is idle for longer than 5ms, the corresponding channel will move to low power mode ONLY. (It means both channels will move to low power mode individually).

In the low power mode, the signal detector will still be monitoring the input channel. If the channel is in low power mode and the input signal is detected, the corresponding channel will wake up.

The device can also be forced into power down mode through the use of the EN_x# pins however this would require the use of GPIO pins to control.

Configuration Table

EN_x#	R _X Det_xx	Function	Input R	Output R
1	X	Channel disable if EN_A#, EN_B#, EN_C#, and EN_D# are high, Chip Power Down	Hi-Z	Hi-Z
0	1	Chip and channel enabled, receiver detect is active	50Ω / Hi-Z*	50Ω / Hi-Z*
0	0	Chip and channel enabled, receiver detect is not active	50Ω	50Ω

* Refer to pin 20 & 41 description

Mode Adjustment

Equalization Setting:

EQ_A/B/C/D are the selection pins for the equalization selection for each direction.

Equalizer setting	
EQ_A/B/C/D	@ 2.5GHz
0	3 dB
open	6dB (Default)
1	9dB

De-emphasis Setting:

DE_A/B/C/D are the selection pins for the de-emphasis selection for each direction.

Output de-emphasis setting	
DE_A/B/C/D	De-emphasis
0	0 dB
open	-3.5 dB
1	-6 dB

Maximum Ratings

(Above which useful life may be impaired. For user guidelines, not tested.)

Storage Temperature.....	-65°C to +150°C
Supply Voltage to Ground Potential.....	-0.5V to +4.6V
DC SIG Voltage	-0.5V to VDD +0.5V
Current Output	-25mA to +25mA
Power Dissipation Continuous	1.0W
Operating Temperature	0 to +70°C
ESD, Human Body Model	-2kV to +2kV
ESD, Machine Model.....	-200V to +200V
ESD, Charged Device Model.....	-500V to +500V

Note: Stresses greater than those listed under MAXIMUM RATINGS may cause permanent damage to the device. This is a stress rating only and functional operation of the device at these or any other conditions above those indicated in the operational sections of this specification is not implied. Exposure to absolute maximum rating conditions for extended periods may affect reliability.

AC/DC Electrical Characteristics

Symbol	Parameter	Conditions	Min.	Typ.	Max.	Units
3.3V Power Supply Characteristics						
V _{DD33}	Power Supply Voltage		3.0		3.6	V
P _{STANDBY33}	Supply Power @3.3V Standby	EN_[A : B : C : D] #=1			3.6	mW
P _{SLUMBER33}	Supply Power @3.3V Slumber	EN_[A : B : C : D] #= 0, no input signal			100	
P _{DEVICE_UNPLUG}	Supply Power Device Unplug	EN_[A : B : C : D] #= 1, R _x Det = 1		6.6		
P _{ACTIVE33}	Supply Power @3.3V Active	EN_[A : B : C : D]# = 0, V _{RX-DIFF-P} ≥ V _{TH-SD}			792	
I _{DD-STANDBY33}	Supply Current @3.3V Standby	EN_[A : B : C : D]# = 1			1	mA
I _{DD-SLUMBER33}	Supply Current @3.3V Slumber	EN_[A : B : C : D]# = 0, no input signal			28	mA
I _{DD-DEVICE_UNPLUG}	Supply Current @3.3V Partial	EN_[A : B : C : D]# = 1, R _x Det = 1		2		mA
I _{DD-ACTIVE33}	Supply Current @3.3V Active	EN_x# = 0, V _{RX-DIFF-P} ≥ V _{TH-SD}			220	
t _{PD}	Latency	From input to output		1	2	ns
CML Receiver Input (100Ω Differential)						

AC/DC Electrical Characteristics (continued)

Symbol	Parameter	Conditions	Min.	Typ.	Max.	Units
Z _{RX-DC}	DC Input Impedance		40	50	60	Ω
Z _{RX-DIFF-DC}	DC Differential Input Impedance		80	100	120	
V _{RX-DIFFP-P}	Differential Input Peak-to-peak Voltage		120		1200	mV
V _{RX-CM-ACP}	AC Peak Common Mode Input Voltage				150	
V _{TH-SD}	Signal detect Threshold	EN_x# = 0	65		175	mVppd
Equalization						
J _{RS}	Residual Jitter	Total Jitter			0.3	Ulp-p

CML Transmitter Output (100Ω differential)¹						
Z _{OUT}	Output Resistance	Single-Ended	40	50	60	Ω
Z _{TX-DIFF-DC}	DC Differential TX Impedance		72	100	120	
V _{TX-DIFFP-P}	Differential Peak-to-peak Output Voltage	$V_{TX-DIFFP-P} = 2 * V_{TX-D+} - V_{TX-D-} $	400		1200	mV
V _{TX-LFPS}	LFPS Differential Peak-to-peak Output Voltage		800			
V _{TX-C}	Common-Mode Voltage	$ V_{TX-D+} + V_{TX-D-} /2$	0.5		1.2	V
V _{cm_ac}	TX AC common mode voltage				100	mVpp
V _{TX-Pre-Ratio-max}	VTX De-emphasis Level				-6	dB
C _{AC-coupling}	AC coupling capacitor		75		200	nF
LVC MOS Control Pins (Pins: 10, 20, 31, 41)						
V _{IH}	Input High Voltage		$0.65 \times V_{DD}$			V
V _{IL}	Input Low Voltage				$0.35 \times V_{DD}$	
I _{IH}	Input High Current				50	μA
I _{IL}	Input Low Current		-50			
Tri-level Control Pins (Pins: 39, 8, 18, 29, 40, 9, 19, 30)						
V _{IH}	Input High Voltage		$0.8 \times V_{DD}$			V
V _{IL}	Input Low Voltage				$0.2 \times V_{DD}$	

Note:

1. Recommended output coupling capacitor is 75nF to 200nF (on each output)

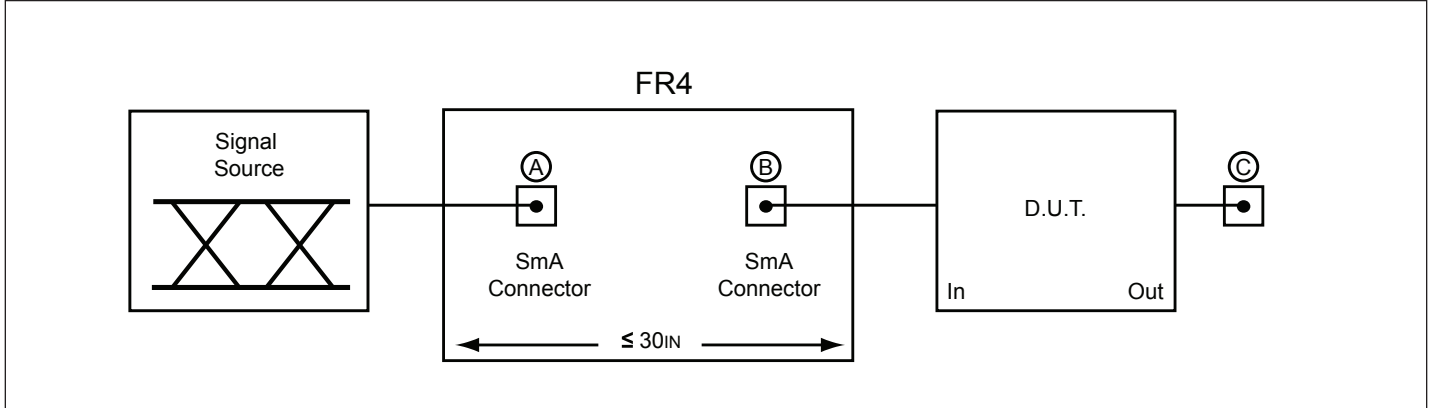

Test Condition Referenced in the Electrical Characteristic Table

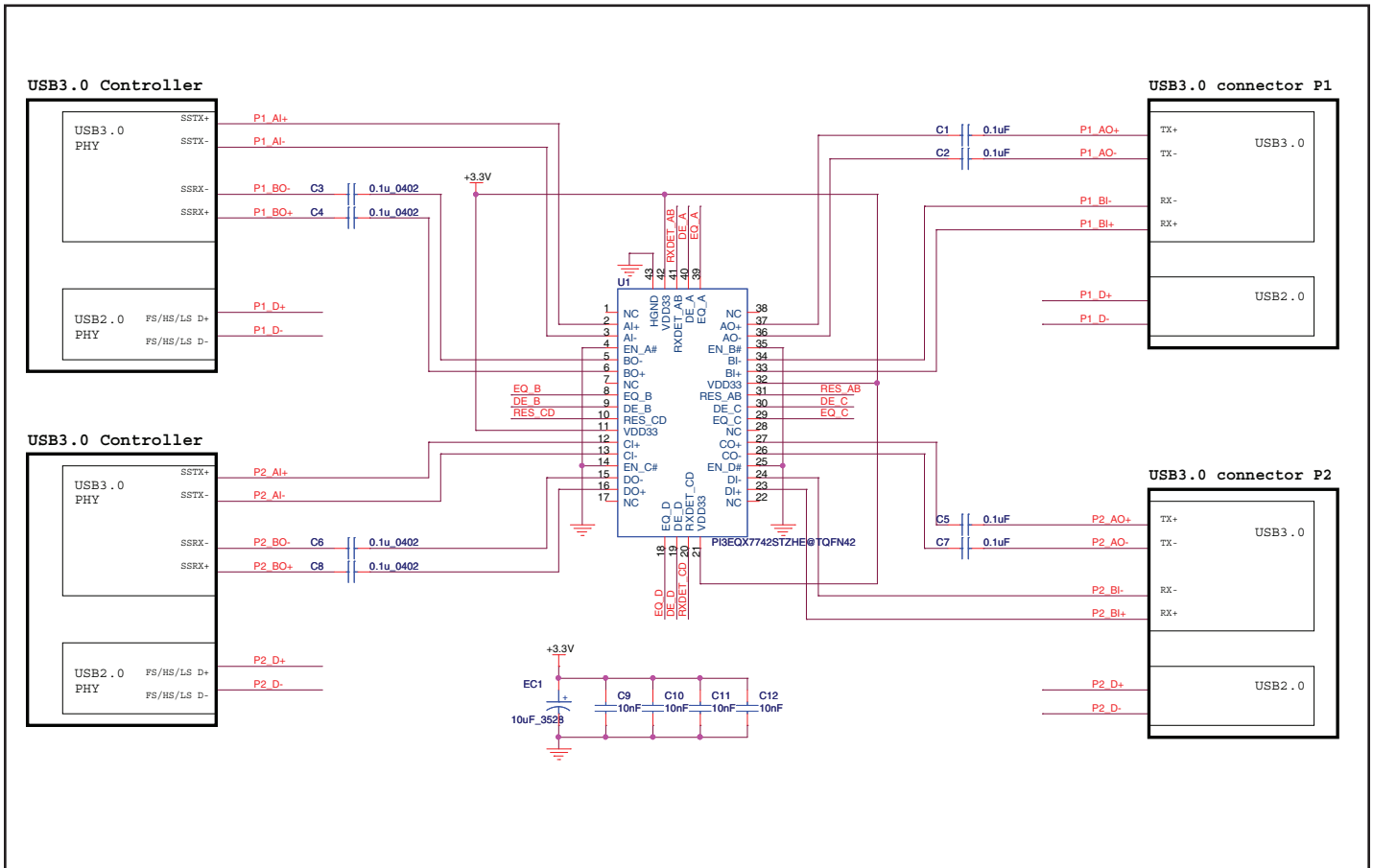

PI3EQX7742ST Application Schematic

Packaging Mechanical: 42-Contact TQFN (ZH)

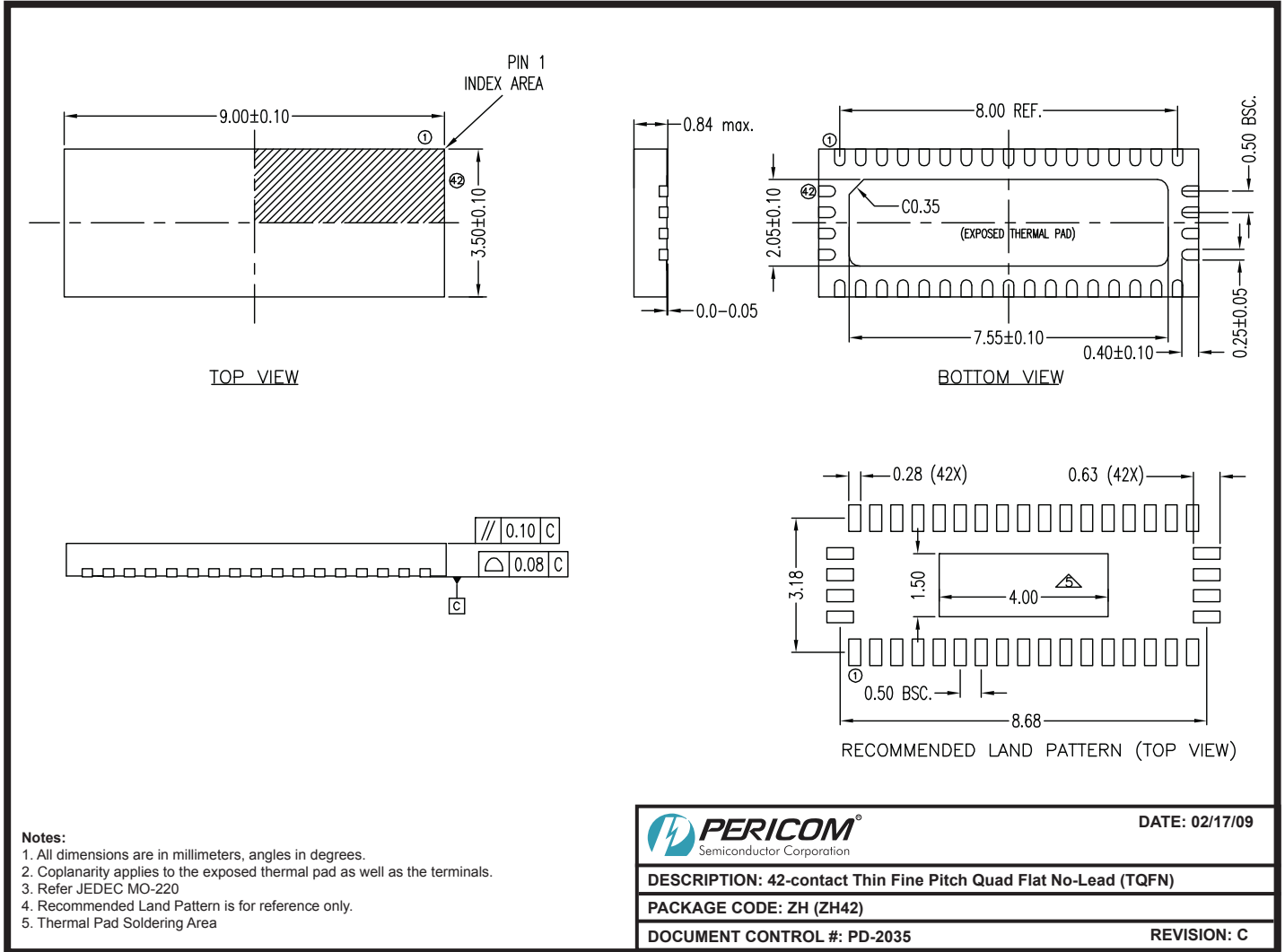

09-0116 Note: For latest package info, please check: <http://www.pericom.com/products/packaging/mechanicals.php>

Ordering Information

Ordering Number	Package Code	Package Description
PI3EQX7742STZHE	ZH	Pb-Free and Green 42-contact TQFN (3.5 x 9mm)

Notes:

- Thermal characteristics can be found on the company web site at www.pericom.com/packaging/
- E = Pb-free and Green
- X suffix = Tape/Reel