



Chipsmall Limited consists of a professional team with an average of over 10 year of expertise in the distribution of electronic components. Based in Hongkong, we have already established firm and mutual-benefit business relationships with customers from,Europe,America and south Asia,supplying obsolete and hard-to-find components to meet their specific needs.

With the principle of “Quality Parts,Customers Priority,Honest Operation,and Considerate Service”,our business mainly focus on the distribution of electronic components. Line cards we deal with include Microchip,ALPS,ROHM,Xilinx,Pulse,ON,Everlight and Freescale. Main products comprise IC,Modules,Potentiometer,IC Socket,Relay,Connector.Our parts cover such applications as commercial,industrial, and automotives areas.

We are looking forward to setting up business relationship with you and hope to provide you with the best service and solution. Let us make a better world for our industry!



## Contact us

Tel: +86-755-8981 8866 Fax: +86-755-8427 6832

Email & Skype: info@chipsmall.com Web: www.chipsmall.com

Address: A1208, Overseas Decoration Building, #122 Zhenhua RD., Futian, Shenzhen, China



**Ultra Small, Low-Input Voltage, Low  $R_{ON}$  Load Switch**

**Features**

- Integrated Load Switch
- Input Voltage: 0.75-V to 3.6-V
- Ultra-Low ON Resistance:
  - Max  $R_{ON}$  over temperature = 9.8m $\Omega$  at  $V_{IN} = 3.6V$
- Ultra Small CSP-8 package
  - 0.95 mm x 1.95 mm, 0.5-mm Pitch
- 4-A Maximum Continuous Switch Current
- Shutdown Current 5.5- $\mu$ A max
- Low Threshold Control Input
- Controlled Slew Rate to Avoid Inrush Currents
- Quick Output Discharge Transistor
- ESD Performance Tested Per JESD 22
  - 4000-V Human-Body Model (A114-B, Class II)
  - 1000-V Charged-Device Model (C101)

**Description**

The PI3PD22919 is a small, ultra-low  $r_{ON}$  load switch with controlled turn on. The device contains a N-channel MOSFET that can operate over an input voltage range of 0.75 V to 3.6 V and switch currents up to 4-A. An integrated charge pump biases the NMOS switch in order to achieve a minimum switch ON resistance ( $r_{ON}$ ). The switch is controlled by an on/off input ( $\overline{ON}$ ), via an active low enable pin.

The PI3PD22919 has a 1250 $\Omega$  on-chip load resistor for quick output discharge when the switch is turned off.

The PI3D22919 has an internally controlled rise time in order to reduce inrush current. The PI3D22919 features a rise time of 880 $\mu$ S at 3.6V.

The PI3D22919 is available in an ultra-small, space-saving 8-pin CSP package and is characterized for operation over the free-air temperature range of -40°C to 85°C.

**Applications**

- Notebook / Netbook Computer
- Tablet PC
- PDAs / Smartphones
- GPS Navigation Devices
- MP3 Players

**Pin Configuration (Bottom View)**

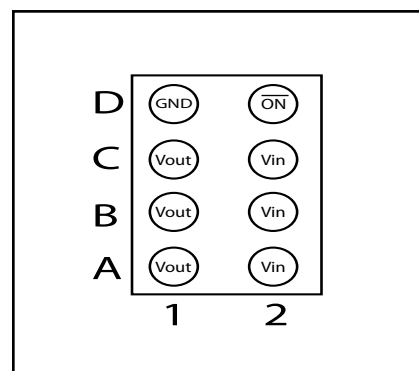

### Functional Block Diagram

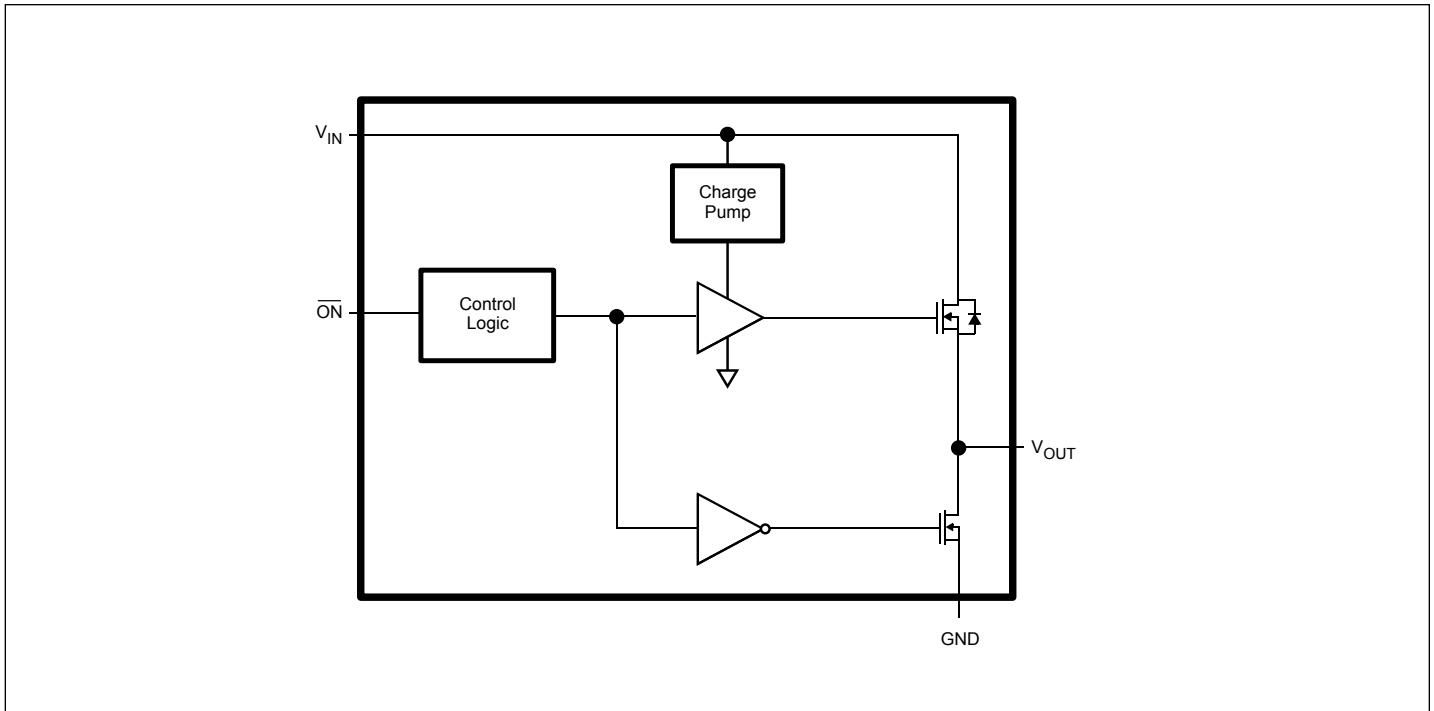

### Function Table

$\overline{ON}$ (Control Input)	$V_{IN}$ to $V_{OUT}$	$V_{OUT}$ to GND
L	ON	OFF
H	OFF	ON

### Pin Description

Terminal		Description
Ball No.	Name	
D1	GND	Ground
D2	$\overline{ON}$	Switch Control Input. Active low, do not leave floating.
A1, B1, C1	$V_{OUT}$	Switch Output
A2, B2, C2	$V_{IN}$	Switch Input. Bypass this input with a ceramic capacitor to ground.

### Absolute Maximum Ratings

$V_{IN}$ , Input voltage range.....	-0.3V to 4V
$V_{OUT}$ , Output voltage range.....	$V_{IN}+0.3V$
$V_{ON}$ , Input voltage range.....	-0.3V to 4V
$I_{MAX}$ , Maximum continuous switch current.....	4A
$I_{PLS}$ , Maximum pulsed current (100- $\mu$ s pulse, 2% duty cycle).....	6A
$T_A$ , Operating free-air temperature range .....	-40°C to 85 °C
$T_J$ , Maximum junction temperature.....	125 °C
$T_{STG}$ , Storage temperature range.....	-65°C to 150 °C
$T_{LEAD}$ , Maximum lead temperature(10-s soldering time).....	300 °C
ESD, Electrostatic discharge protection , Charged Device Model(CDM).....	1000V
Human-Body Model(HBM).....	4000V

**Note:**

Stresses beyond those listed under absolute maximum ratings may cause permanent damage to the device. These are stress ratings only, and functional operation of the device at these or any other conditions beyond those indicated under Recommended Operating Conditions is not implied. Exposure to absolute-maximum-rated conditions for extended periods may affect device reliability.

### Recommended Operating Conditions

Symbol	Parameter	Min.	Max.	Unit	
$V_{IN}$	Input voltage range	0.75	3.6	V	
$V_{OUT}$	Output voltage range		$V_{IN}$	V	
$V_{IH}$	High-level input voltage range, ON	$V_{IN} = 2.5 V$ to 3.6 V	1.2	3.6	V
		$V_{IN} = 0.75 V$ to 2.5 V	0.9	3.6	V
$V_{IL}$	Low-level input voltage range, ON	$V_{IN} = 2.5 V$ to 3.6 V		0.6	V
		$V_{IN} = 0.75 V$ to 2.49 V		0.4	V
$C_{IN}$	Input capacitor	1 <sup>(1)</sup>		$\mu$ F	

**DC Electrical Characteristics** Unless otherwise specified,  $V_{IN} = 0.75V$  to  $3.6V$

Parameter	Conditions	$T_A^1$	Min.	Typ.	Max.	Unit	
<b>Power Switch</b>							
$I_{IN}$	Quiescent current	$I_{OUT} = 0, V_{ON} = GND$	Full		68	160	$\mu A$
					40	70	
					25	350	
					103	200	
					78	110	
					37	70	
$I_{IN(LEAKAGE)}$	OFF-state supply current	$V_{IN} = V_{ON} = 3.6V, V_{OUT} = 0$	Full		5.5	$\mu A$	
$R_{ON}$	ON-state resistance	$I_{OUT} = -200 mA$	25°C	Full	7.1	8.8	$m\Omega$
					9.8		
			25°C	Full	7.2	8.9	
					9.9		
			25°C	Full	7.3	9.1	
					10.1		
			25°C	Full	6.9	9.1	
					10.4		
			25°C	Full	7	9.2	
					10.6		
			25°C	Full	7.6	10.2	
					11.6		
$r_{PD}$	Output pulldown resistance	$V_{IN} = V_{ON} = 3.3V, I_{OUT} = 3mA$	Full		1250	1500	$\Omega$
$I_{ON}$	ON input leakage current	$V_{ON} = 0.9V$ to $3.6V$ or GND	Full		0.1	$\mu A$	

**Note:**

1. Typical values are at  $V_{IN} = 3.3V$  and  $T_A = 25^\circ C$ .
2. See Output Pulldown in Application Information.

**Switching Characteristics**

Symbol	Parameter	Conditions			Min.	Typ.	Max.	Units
$V_{IN} = 3.6V, T_A = 25^\circ C$ (Unless otherwise specified)								
$t_{ON}$	Turn-ON time	$R_L = 10\Omega$	$C_L = 0.1\mu F$	$V_{IN} = 3.6V$		970		$\mu s$
$t_{OFF}$	Turn-OFF time					3		$\mu s$
$t_r$	$V_{OUT}$ rise time					880		$\mu s$
$t_f$	$V_{OUT}$ fall time					2		$\mu s$
$V_{IN} = 0.9V, T_A = 25^\circ C$ (Unless otherwise specified)								
$t_{ON}$	Turn-ON time	$R_L = 10\Omega$	$C_L = 0.1\mu F$	$V_{IN} = 0.9V$		840		$\mu s$
$t_{OFF}$	Turn-OFF time					16		$\mu s$
$t_r$	$V_{OUT}$ rise time					470		$\mu s$
$t_f$	$V_{OUT}$ fall time					5		$\mu s$

**Parameter Measurement Information**

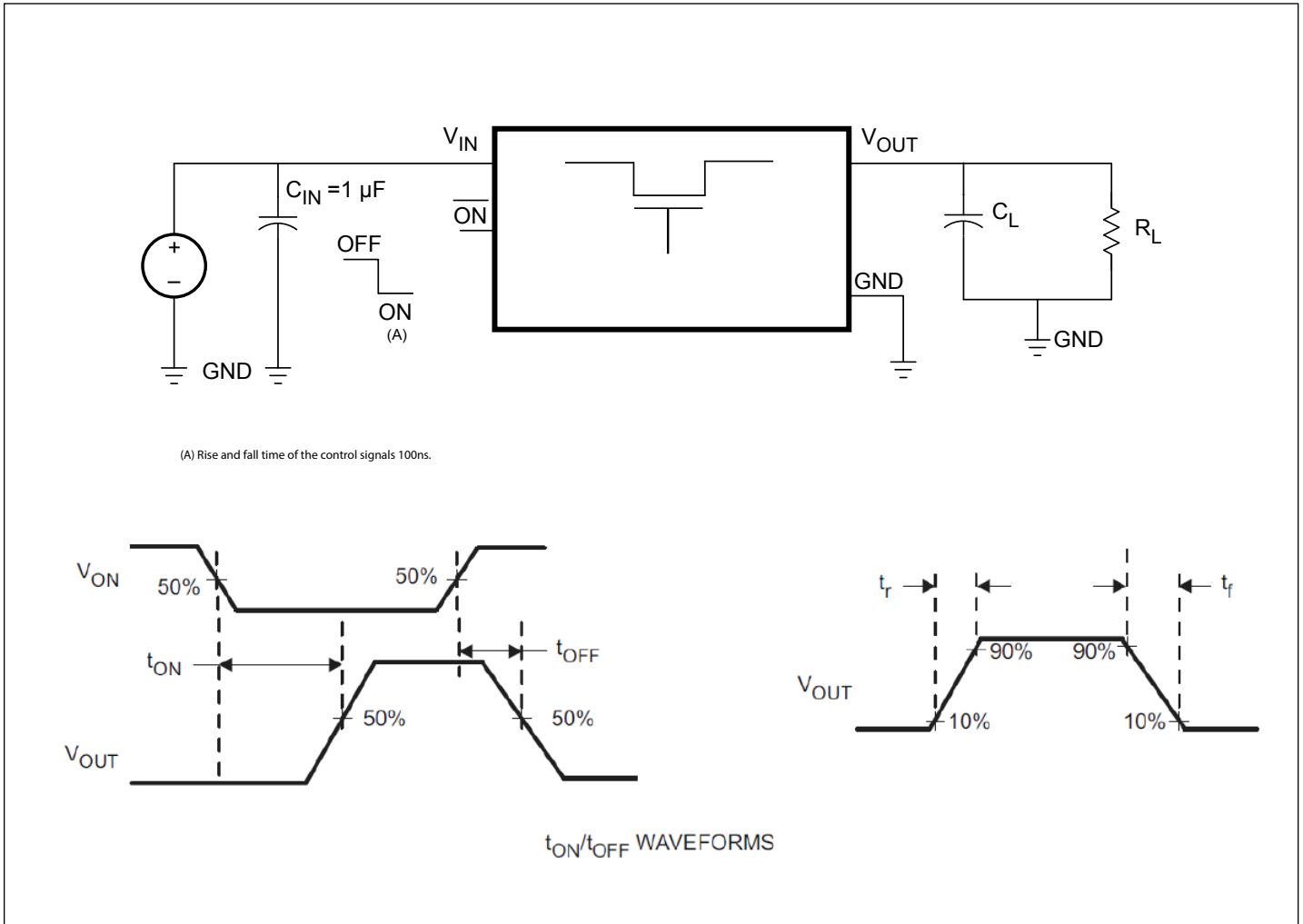

**Typical Characteristics**

**ON-STATE RESISTANCE vs  
INPUT VOLTAGE**

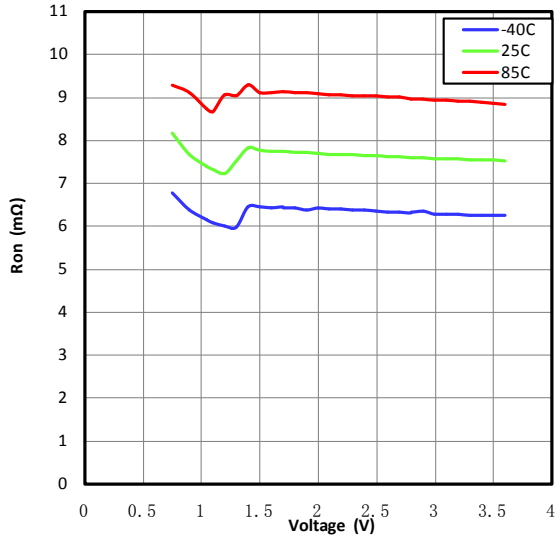

**ON-STATE RESISTANCE vs  
TEMPERATURE**

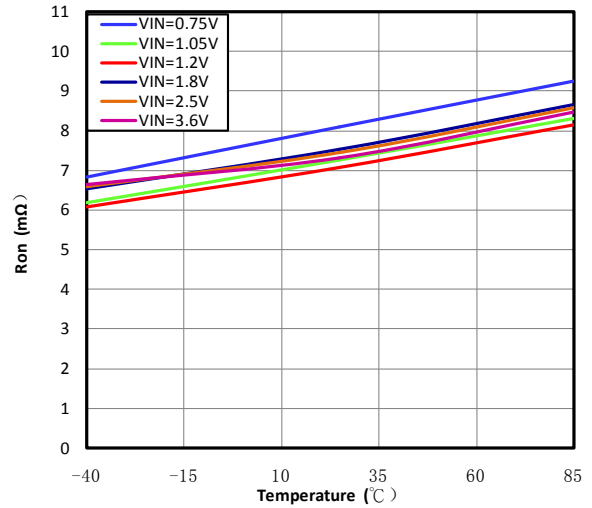

**INPUT CURRENT, QUIESCENT vs  
INPUT VOLTAGE**

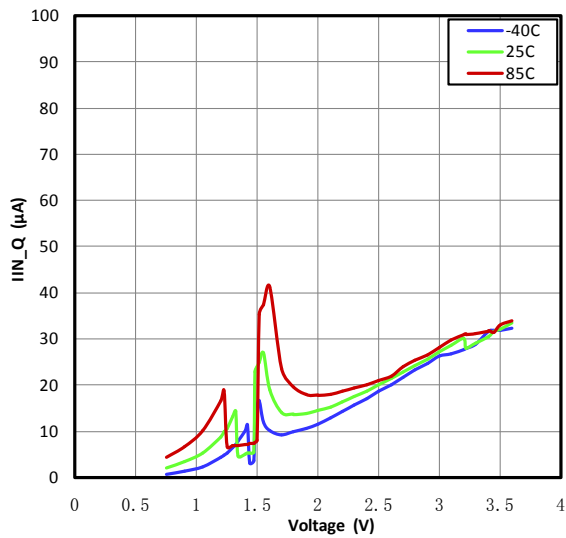

**INPUT CURRENT, LEAK vs  
INPUT VOLTAGE**

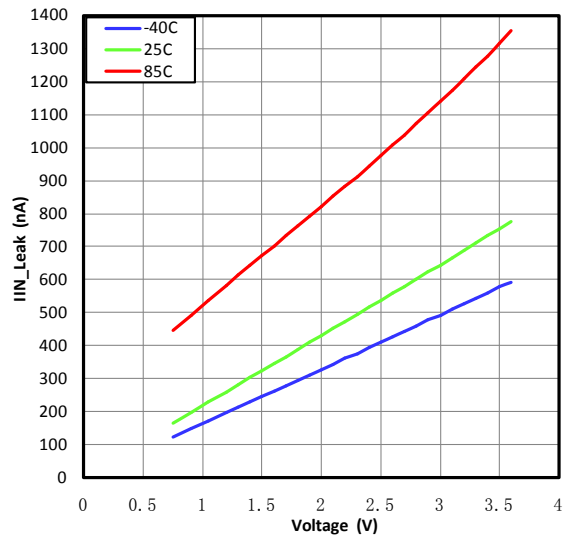

**ON INPUT THRESHOLD**

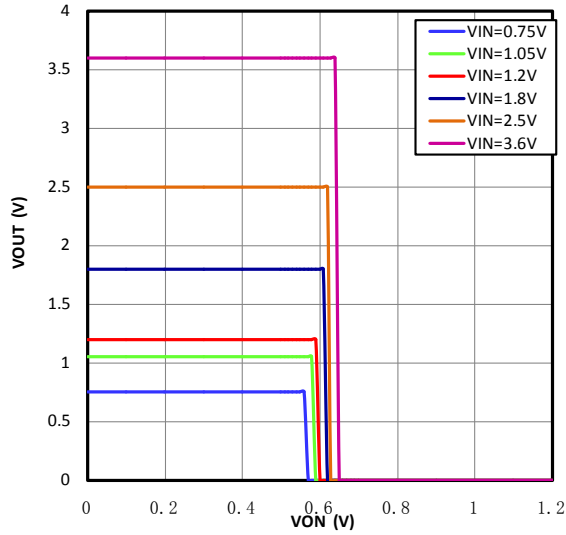

**TURN-ON TIME vs TEMPERATURE**

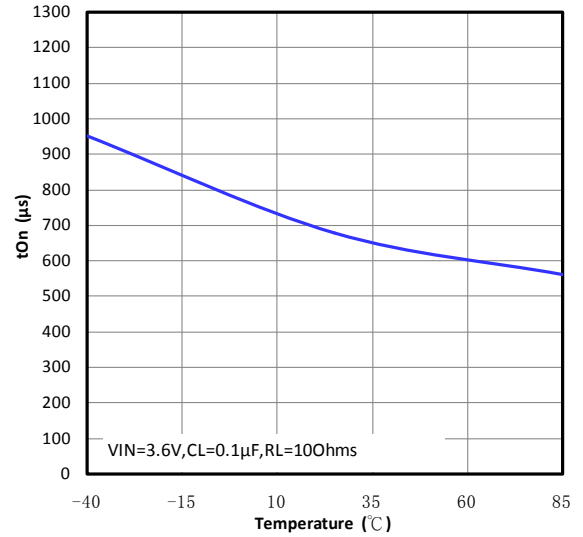

**TURN-OFF TIME vs TEMPERATURE**

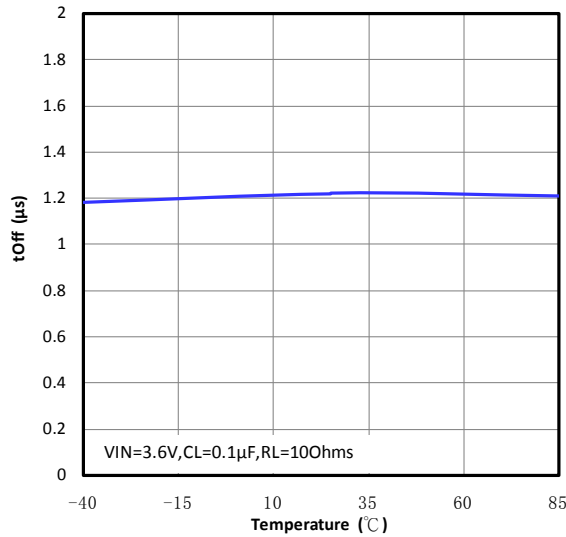

**RISE TIME vs TEMPERATURE**

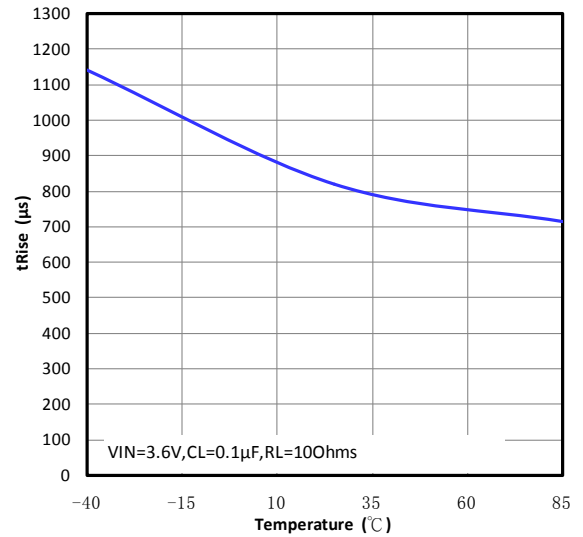



**FALL TIME vs TEMPERATURE**

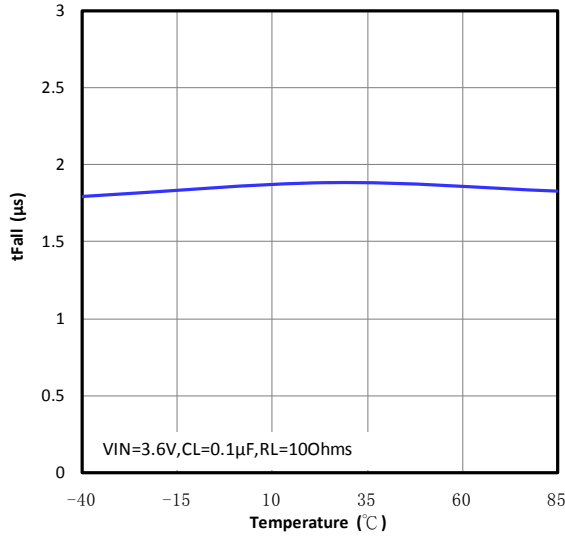

**TURN-ON TIME vs TEMPERATURE**

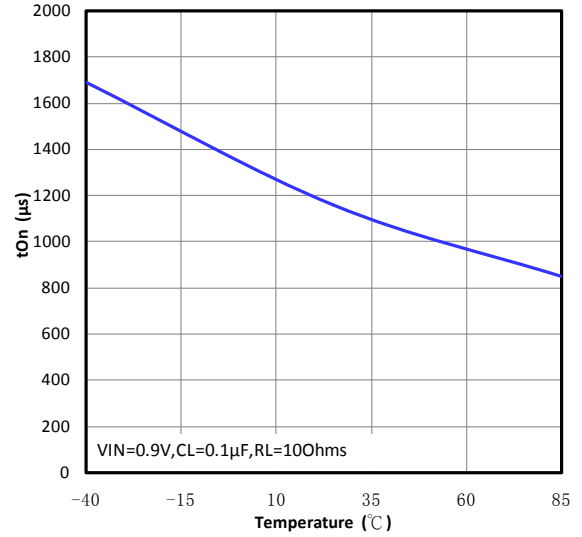

**TURN-OFF TIME vs TEMPERATURE**

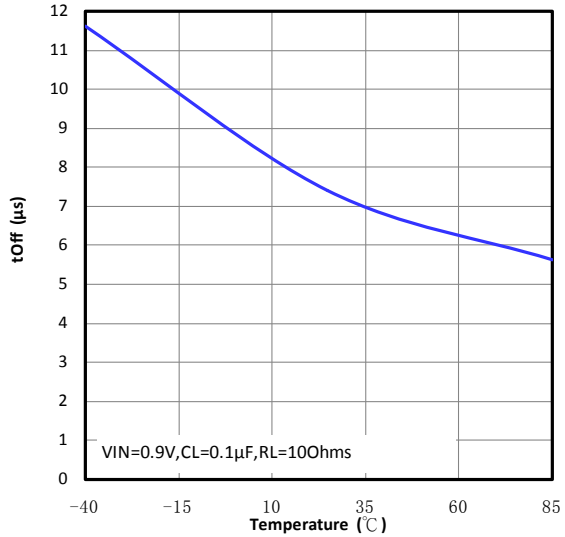

**RISE TIME vs TEMPERATURE**

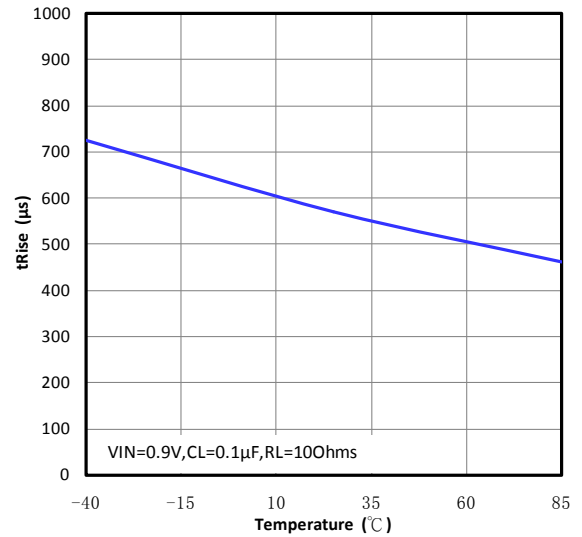

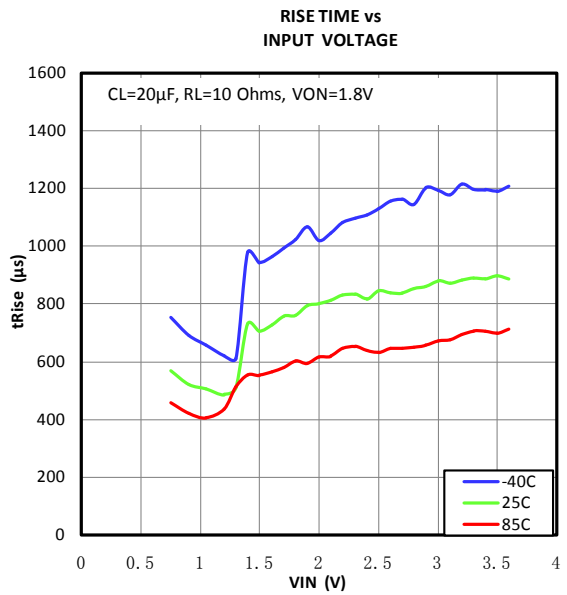
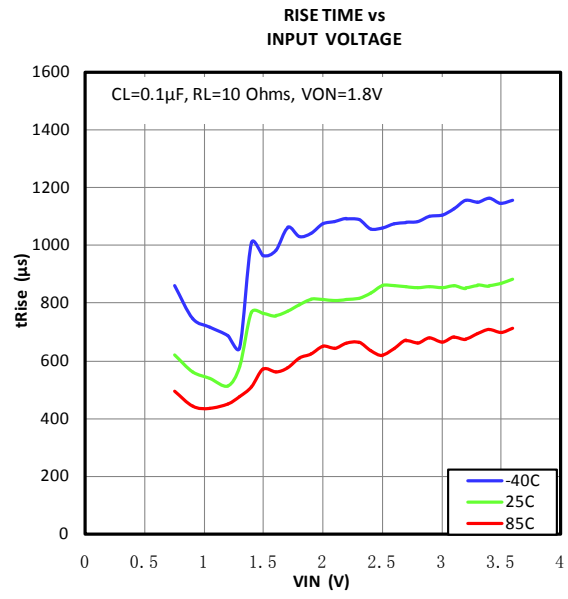
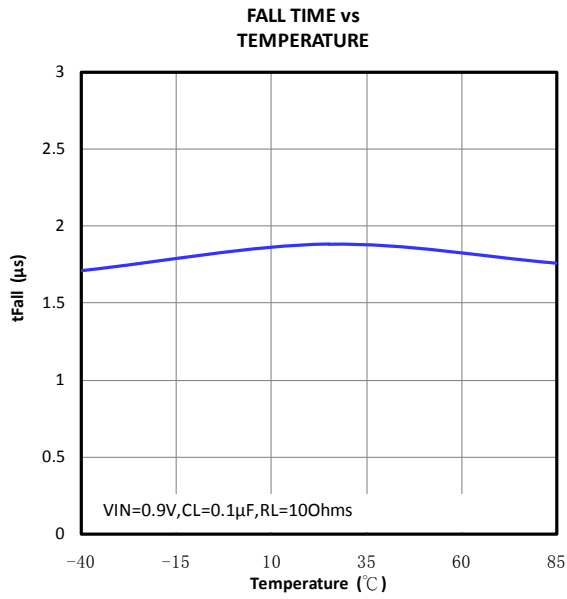

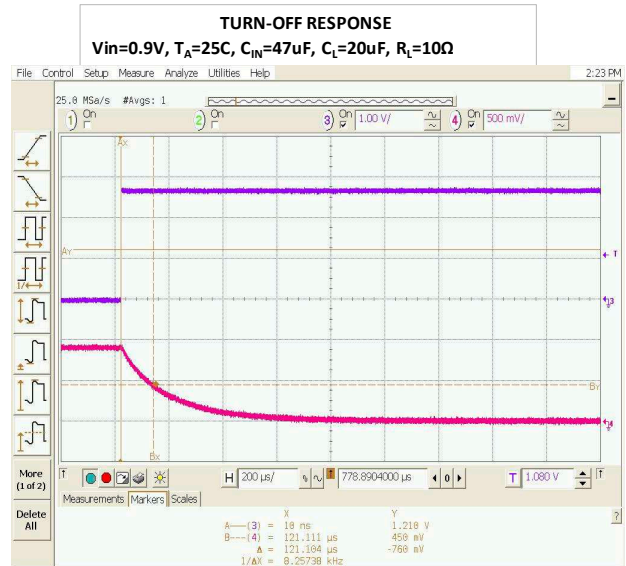
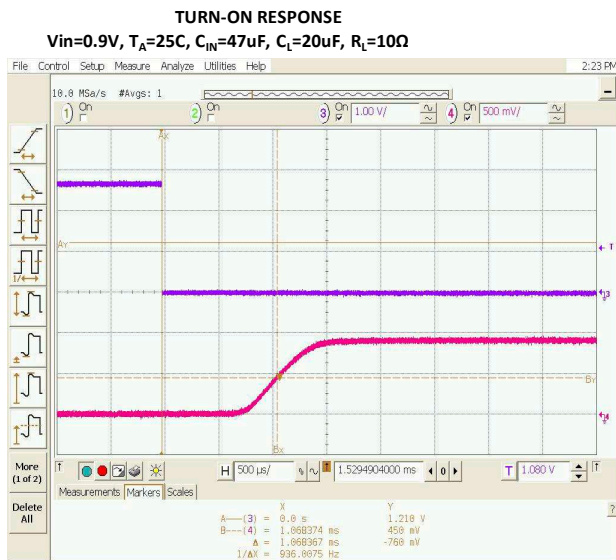
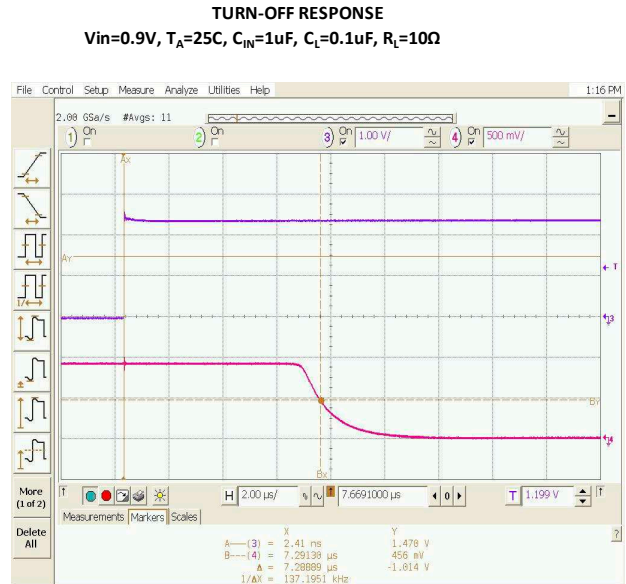
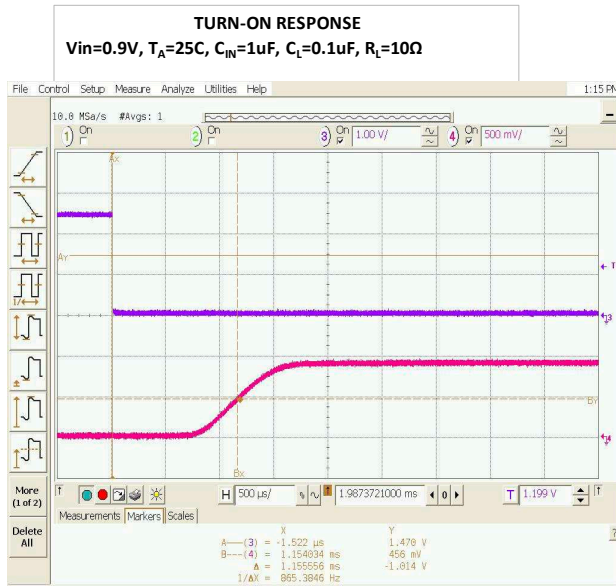

**TURN-ON RESPONSE**

**Vin=3.6V, TA=25C, CIN=1uF, CL=0.1uF, RL=10Ω**

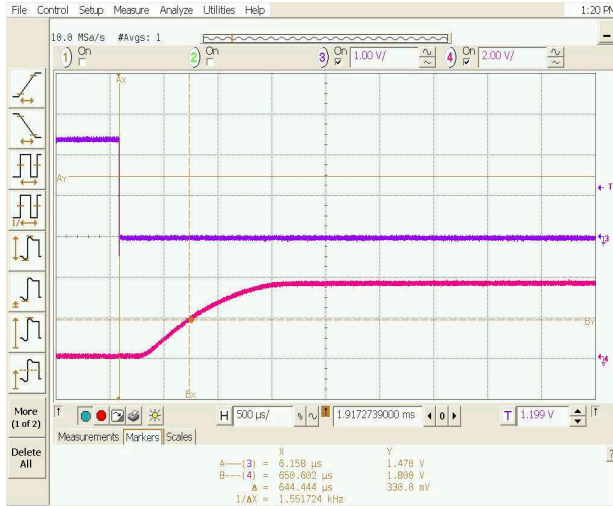

**TURN-OFF RESPONSE**

**Vin=3.6V, TA=25C, CIN=1uF, CL=0.1uF, RL=10Ω**

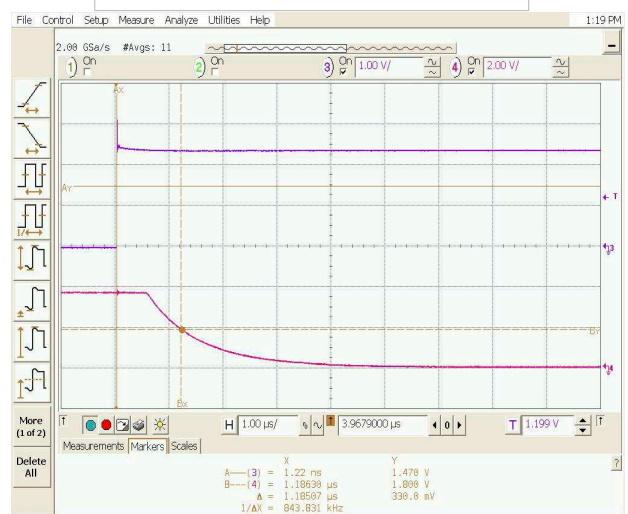

**TURN-ON RESPONSE**

**Vin=3.6V, TA=25C, CIN=47uF, CL=20uF, RL=10Ω**

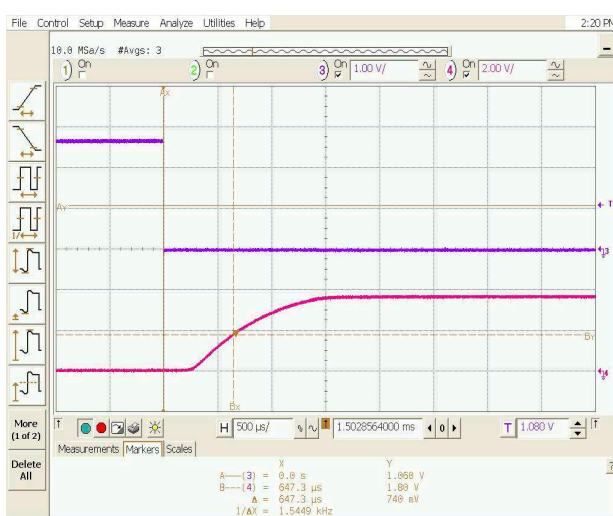

**TURN-OFF RESPONSE**

**Vin=3.6V, TA=25C, CIN=47uF, CL=20uF, RL=10Ω**

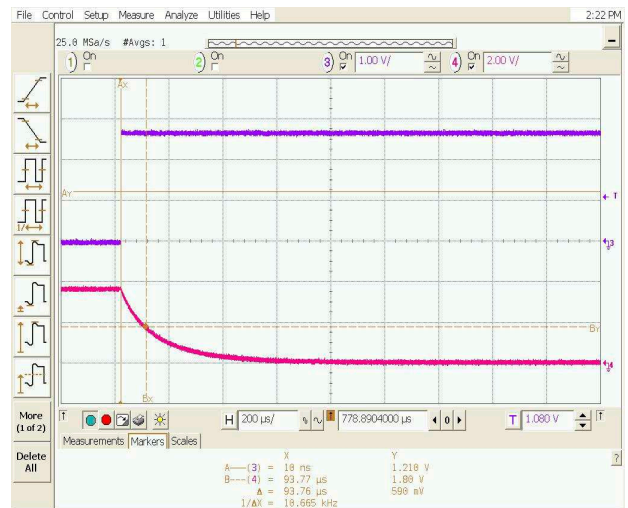

**Packaging Mechanicals: 8-contact CSP (GB)**

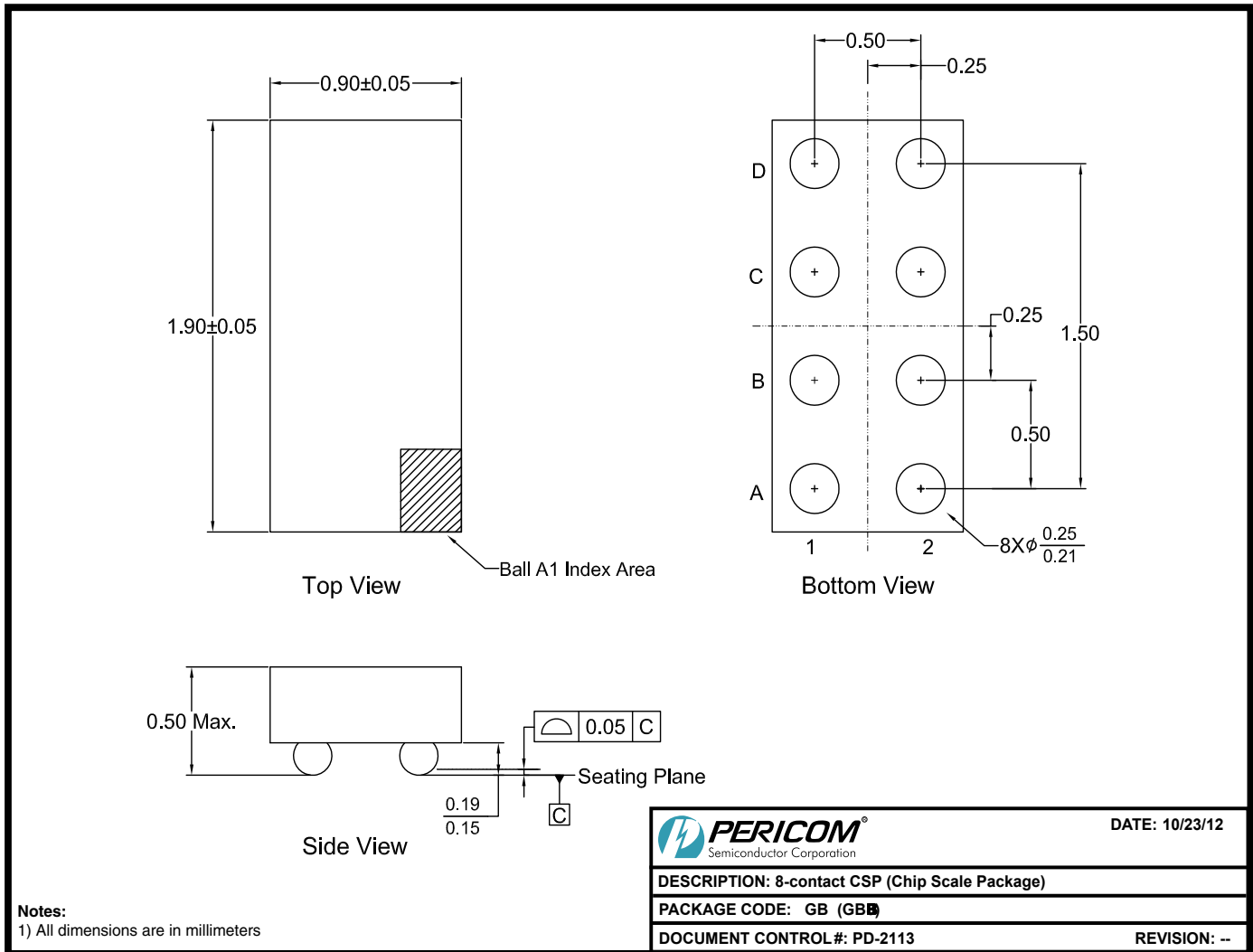

**Ordering Information<sup>(1-3)</sup>**

Ordering Code	Package Code	Package Description
PI3PD22919GBE	GB	8-contact Chip Scale Package (CSP), Pb-free & Green

**Notes:**

1. Thermal characteristics can be found on the company web site at [www.pericom.com/packaging/](http://www.pericom.com/packaging/)
2. E = Pb-free and Green
3. Adding an X suffix = Tape/Reel