



Chipsmall Limited consists of a professional team with an average of over 10 year of expertise in the distribution of electronic components. Based in Hongkong, we have already established firm and mutual-benefit business relationships with customers from,Europe,America and south Asia,supplying obsolete and hard-to-find components to meet their specific needs.

With the principle of “Quality Parts,Customers Priority,Honest Operation,and Considerate Service”,our business mainly focus on the distribution of electronic components. Line cards we deal with include Microchip,ALPS,ROHM,Xilinx,Pulse,ON,Everlight and Freescale. Main products comprise IC,Modules,Potentiometer,IC Socket,Relay,Connector.Our parts cover such applications as commercial,industrial, and automotives areas.

We are looking forward to setting up business relationship with you and hope to provide you with the best service and solution. Let us make a better world for our industry!



## Contact us

Tel: +86-755-8981 8866 Fax: +86-755-8427 6832

Email & Skype: info@chipsmall.com Web: www.chipsmall.com

Address: A1208, Overseas Decoration Building, #122 Zhenhua RD., Futian, Shenzhen, China



## PI3USB102J

USB 2.0 High-Speed (480 Mbps) Switch with 5V Protection

### Description

The PI3USB102J is a single differential channel 2:1 multiplexer/demultiplexer USB 2.0 Switch. Industry leading advantages include a propagation delay of 250ps, resulting from its low channel resistance and I/O capacitance. PI3USB102J is bidirectional and offers very little attenuation of high-speed signals. It is designed for low bit-to-bit skew, high channel-to-channel noise isolation and is compatible with various standards, such as High Speed USB 2.0 (480 Mb/s).

The PI3USB102J offers over voltage protection for the Y+/Y- pins as per the USB 2.0 specification. With the chip powered on or off if Y+/Y- pins are shorted to VBUS (5V +/- 5%) a less than 3.6V signal will transmit through M+/M- and D+/D- outputs after 300ns.

### Applications

- Routes signals for USB 2.0
- PC, Notebooks and Hand-held devices

### Block Diagram

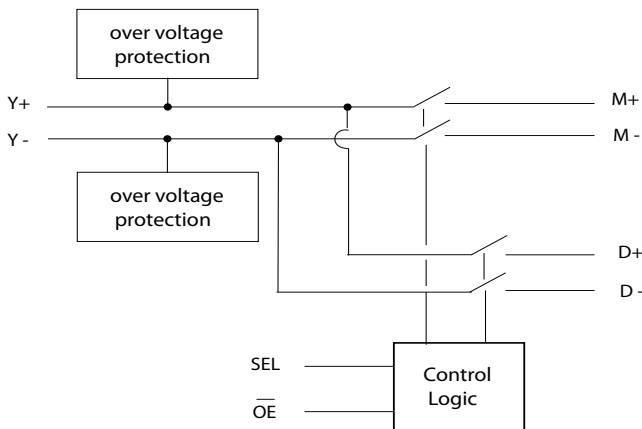

### Features

- USB 2.0 compliant (high speed, full speed, and low speed)
- RON: 2.0Ω typical @ VIN < 0.5V
- Channel On Capacitance: 7.0pF (Max)
- Wide -3dB Bandwidth: 1,600MHz
- Low bit-to-bit skew
- Low Crosstalk: -29dB @ 480 Mbps
- Off Isolation: -28dB @ 480 Mbps
- Near-Zero propagation delay: 250ps
- Support 1.8-V logic on control pins
- VDD Operating Range: 3.0V to 3.6V
- Data pin I/O, ESD: 8kV HBM
- I/O pins are protected and can tolerate a short to VBUS
- Y+/Y- can provide over-voltage protection to M/D ports
- Packaging (Pb-free & Green):  
10-contact, X2QFN, 1.4mm x 1.2mm x 0.35mm (XUC)
- Low supply current: 30nA (Typ)
- Operating temperature: -20oC to 100oC