



Chipsmall Limited consists of a professional team with an average of over 10 year of expertise in the distribution of electronic components. Based in Hongkong, we have already established firm and mutual-benefit business relationships with customers from,Europe,America and south Asia,supplying obsolete and hard-to-find components to meet their specific needs.

With the principle of “Quality Parts,Customers Priority,Honest Operation,and Considerate Service”,our business mainly focus on the distribution of electronic components. Line cards we deal with include Microchip,ALPS,ROHM,Xilinx,Pulse,ON,Everlight and Freescale. Main products comprise IC,Modules,Potentiometer,IC Socket,Relay,Connector.Our parts cover such applications as commercial,industrial, and automotives areas.

We are looking forward to setting up business relationship with you and hope to provide you with the best service and solution. Let us make a better world for our industry!



## Contact us

Tel: +86-755-8981 8866 Fax: +86-755-8427 6832

Email & Skype: info@chipsmall.com Web: www.chipsmall.com

Address: A1208, Overseas Decoration Building, #122 Zhenhua RD., Futian, Shenzhen, China



### Features

- Hot Plug Detect Signal Generator for VGA connectors
- Generates hot plug output signal telling system when monitor is present or not
- Power Supply, 3.3V and 5.0V
- ESD tolerance on pin 7 is up to +/-4kV contact per IEC61000-4-2 specification
- -3dB BW of 1.7GHz (typ)
- 4.75 Ohm On Resistance with 0.5 Ohm flatness (typ)
- Low input/output capacitance (Con = 4.5pF, typ)
- Packaging (Pb-free and Green):
  - 8-contact MSOP (U)

### Description

The VGA connector does not have a hot-plug pin to tell the system that a monitor is connected. More recent video standards, such as HDMI and DisplayPort, save power by adding a hot-plug pin which allows graphics outputs to be powered down when a monitor is not connected.

Pericom's PI3VST01 HPD signal generator generates a monitor detection signal from a VGA source connector to tell the VGA source if an external monitor is connected or not.

PI3VST01 allows notebook makers to shut off the VGA DAC when a monitor is not connected, thus saving 170 mW per DAC. PI3VST01 dissipates only 0.66 mW.

The monitor detection scheme within the PI3VST01 will not affect normal operation of the video driver.

### Block Diagram

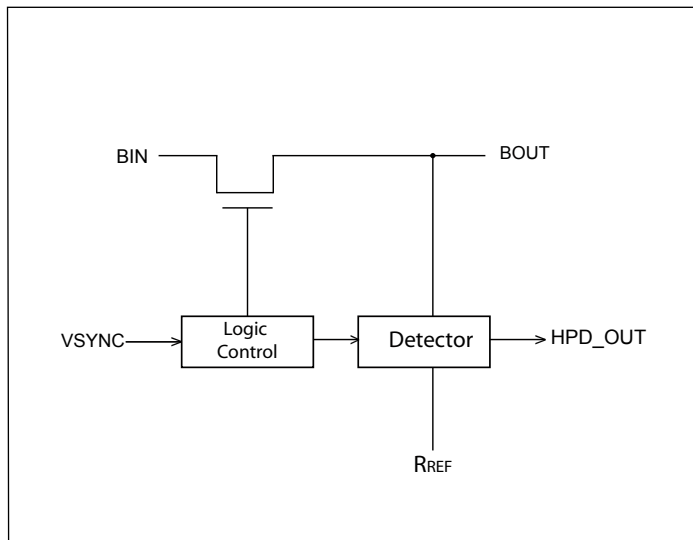

### Pin Configuration-U8 (Top View)

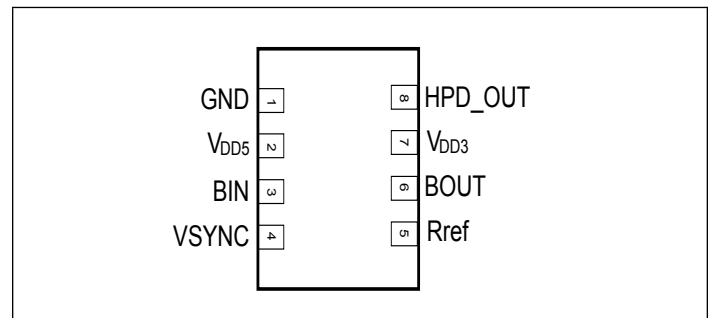

**Pinout Table**

Pin #	Pin Name	I/O Type	Description
1	GND	Ground	Ground
2	V <sub>DD5</sub>	Power	5V ± 10% power rail
3	BIN	I	Blue input from VGA source
4	VS <sub>YNC</sub>	I	Vertical Synchronization signal, internal 250KOhm pulldown
8	HPD_OUT	O	Open drain output, telling the system the status of the external VGA monitor. If VGA monitor is present, this pin will be pulled low. If VGA monitor is not present, this pin will be Hi-z
7	V <sub>DD3</sub>	Power	3.3V ± 10% power rail
6	BO <sub>UT</sub>	O	Blue output to VGA connector
5	Rref	I/O	Determines IC mode in terms of impedance detection levels. connect to external resistor to GND. Resistor values can be determined by looking at truth table

### Absolute Ratings

(Above which the useful life may be impaired. For user guidelines, not tested)

V <sub>DD3</sub> (Power Supply).....	-0.5V to 4.0V
V <sub>DD5</sub> (Power Supply).....	-0.5V to 6V
Storage Temperature.....	-55°C to +150°C

**Note:**

Stresses greater than those listed under MAXIMUM RATINGS may cause permanent damage to the device. This is a stress rating only and functional operation of the device at these or any other conditions above those indicated in the operational sections of this specification is not implied. Exposure to absolute maximum rating conditions for extended periods may affect reliability.

### DC Electrical Characteristics for Video Switching over Operating Range

(T<sub>A</sub> = -40°C to +85°C, V<sub>DD3</sub> = 3.3V±10%, V<sub>DD5</sub> = 5.0V±10%)

Parameters	Description	Test Conditions	Min.	Typ.	Max.	Units
R <sub>ON</sub>	Switch On-Resistance, BIN to BOUT	V <sub>DD</sub> = Min., 0V ≤ V <sub>input</sub> ≤ 1.2V, I <sub>input</sub> = -40mA	-	4.75	5.5	ohm
R <sub>FLAT(ON)</sub>	On-Resistance Flatness, BIN to BOUT	V <sub>DD</sub> = Min., V <sub>input</sub> @ 0V and 1.2V, I <sub>input</sub> = -40mA	-	0.5	1	
V <sub>IH,VSYNC</sub>	Input High Voltage, VSYNC		2.4			V
V <sub>IL,VSYNC</sub>	Input Low Voltage, VSYNC		0		0.5	V
V <sub>OL,HPD_OUT</sub>	Output Low Voltage, HPD_OUT	I <sub>OL</sub> = 2mA	0		0.4	V
I <sub>IL</sub>	Input leakage current, BIN	V <sub>IN</sub> = 0V	-1		1	uA
I <sub>IH</sub>	Input leakage current, BIN	V <sub>IN</sub> = 3.6V	-1		1	uA
I <sub>OZL</sub>	Output leakage current, BOUT	V <sub>OUT</sub> = 0V	-1		1	uA
I <sub>OZH</sub>	Output leakage current, BOUT	V <sub>OUT</sub> = 3.6V	-1		1	uA
I <sub>OZH,HPD_OUT</sub>	Output Leakage Current, HPD_OUT	V <sub>OZ</sub> = V <sub>DD</sub>			1	uA

### Power Supply Characteristics

(T<sub>A</sub> = -40°C to +85°C)

Parameters	Description	Min.	Typ.	Max.	Units
I <sub>DD3</sub>	Current Consumption for 3.3V Rail, case 75//75 or 150//75		200	400	uA
I <sub>DD5</sub>	Current Consumption for 5V Rail, case 75//75 or 150//75		0.5	1	uA

### Dynamic Electrical Characteristics over Operating Range

( $T_A = -40^\circ \text{ to } +85^\circ \text{C}$ ,  $V_{DD3} = 3.3\text{V} \pm 10\%$ ,  $GND = 0\text{V}$ ,  $V_{DD5} = 5.0\text{V} \pm 10\%$ )

Parameters	Description	Test Conditions	Min.	Typ.	Max.	Units
OIRR	OFF Isolation, BIN to BOUT	$f = 250\text{MHz}$	-	-46	-	dB
BW	Bandwidth -3dB, BIN to BOUT		-	2.0	-	GHz
$t_{PD}$	Propagation Delay, BIN to BOUT		-	90	-	ps
$I_{LOSS}$	Insertion Loss for B path	with 75-Ohm load	Freq = 10MHz (VGA)	-0.3		dB
			Freq = 100MHz (XGA)	-0.33		
			Freq = 300MHz (UXGA)	-0.4		

### Capacitance ( $T_A = 25^\circ \text{C}$ , $f = 1\text{MHz}$ )

Parameters	Description	Test Conditions	Typ.	Units
$C_{OFF}$	Capacitance, Switch OFF		2.4	pF
$C_{ON}$	Switch Capacitance between BIN and BOUT, Switch ON		5.6	pF

### Applications

VGA-DACs in chipsets as well as video chips (MXM, GPU, DP-to-VGA, PCIe, etc.) typically dissipate about 170 mW.

The VGA standard does not have a monitor detect feature, so the DAC dissipates power whether the monitor is connected or not.

PI3VST01 provides an HPD\_OUT signal that detects the presence of a monitor. This HPD\_OUT signal can be routed to the chipset, directly, or through an MPU, to turn off the VGA DAC when a monitor is not connected. Using the PI3VST01, the system can save 170 mW when the monitor is not connected.

PI3VST01 can also be used to enable automatic switching between two monitors. Another Pericom product, PI3V724 integrates 2 monitor detection circuits with a 1:2 VGA switch and offers both automatic and manual monitor switching.

### VGA Termination

PI3VST01 can support two different termination schemes:

- Case\_75//75: Reverse termination for the monitor is provided by a 75 Ohm resistor at the connector, as per the VESA VSIS specification.
- Case\_150//75: Reverse termination for the monitor is split between a 150 Ohm resistor at the connector and a 150 Ohm resistor at the video DAC, as required by some chipsets.

An external resistor must be supplied between the Rref pin and ground to tell the detection circuit which termination scheme is being used. Values for this resistor are shown below.

Rref	Application Case Supported
330Kohm +/-5%	Case_150//75
200Kohm +/-5%	Case_75//75



**Application Schematics**

In order to ensure accurate color balance, gain and frequency response are matched between the R, G, and B channels using:

- 4.7 Ohm resistors in series with the R and G lanes,
- 8.2 pF capacitors to ground from the R and G lanes, and
- a 2 pF capacitor to ground on the B lane.

To pass the VESA VSIS specification, many VGA DACs require series inductors to reduce overshoot and undershoot.

A 47 kOhm resistor is used as a pullup for the open-drain HPD\_OUT signal from the PI3VST01 to the VGA DAC control.

4.7 uF capacitors should be used to bypass both VDD5 and VDD3.

The schematic below illustrates the recommended design for the 150//75 case.

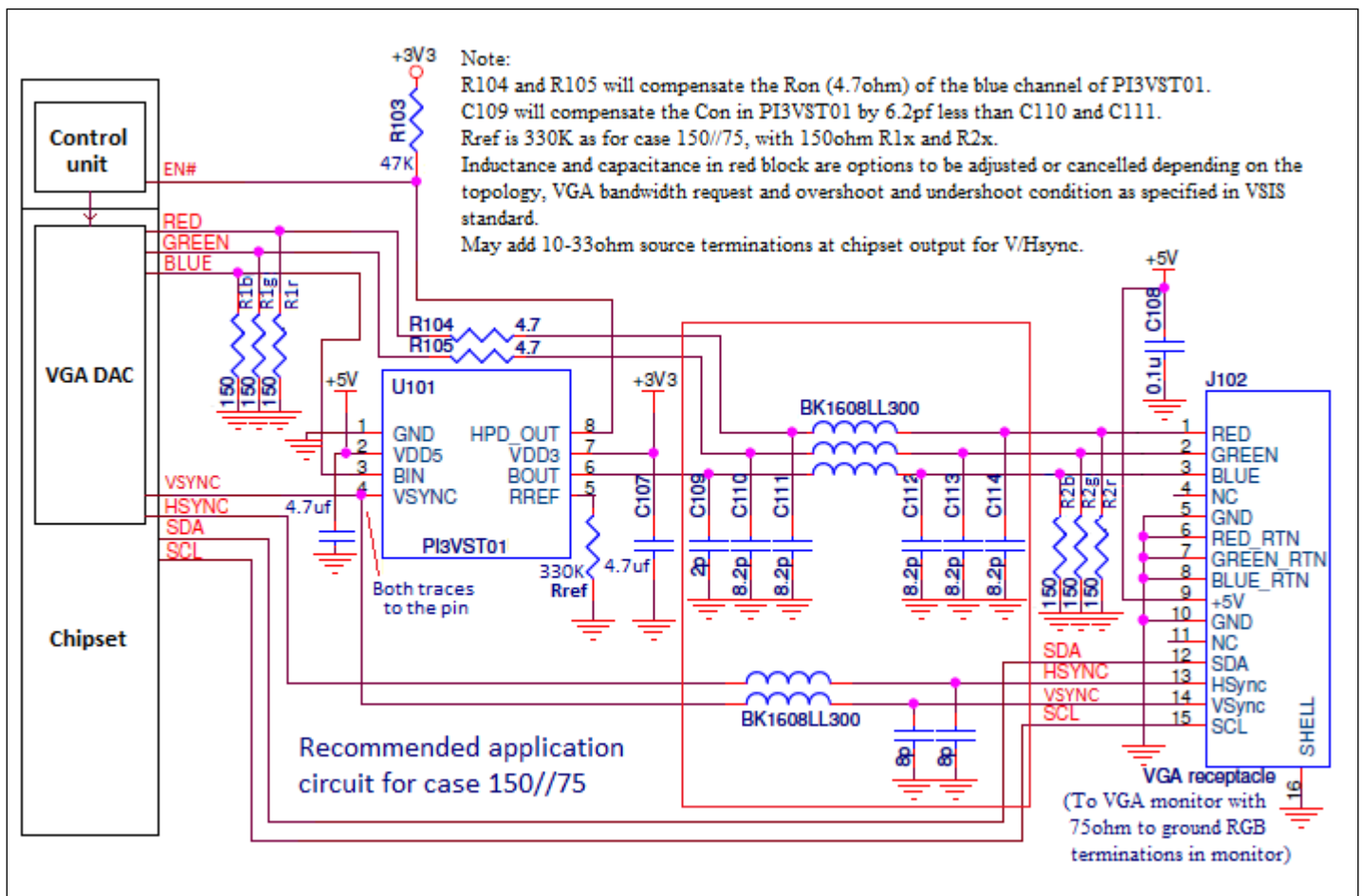

The schematic below illustrates the recommended design for the 75//75 case.

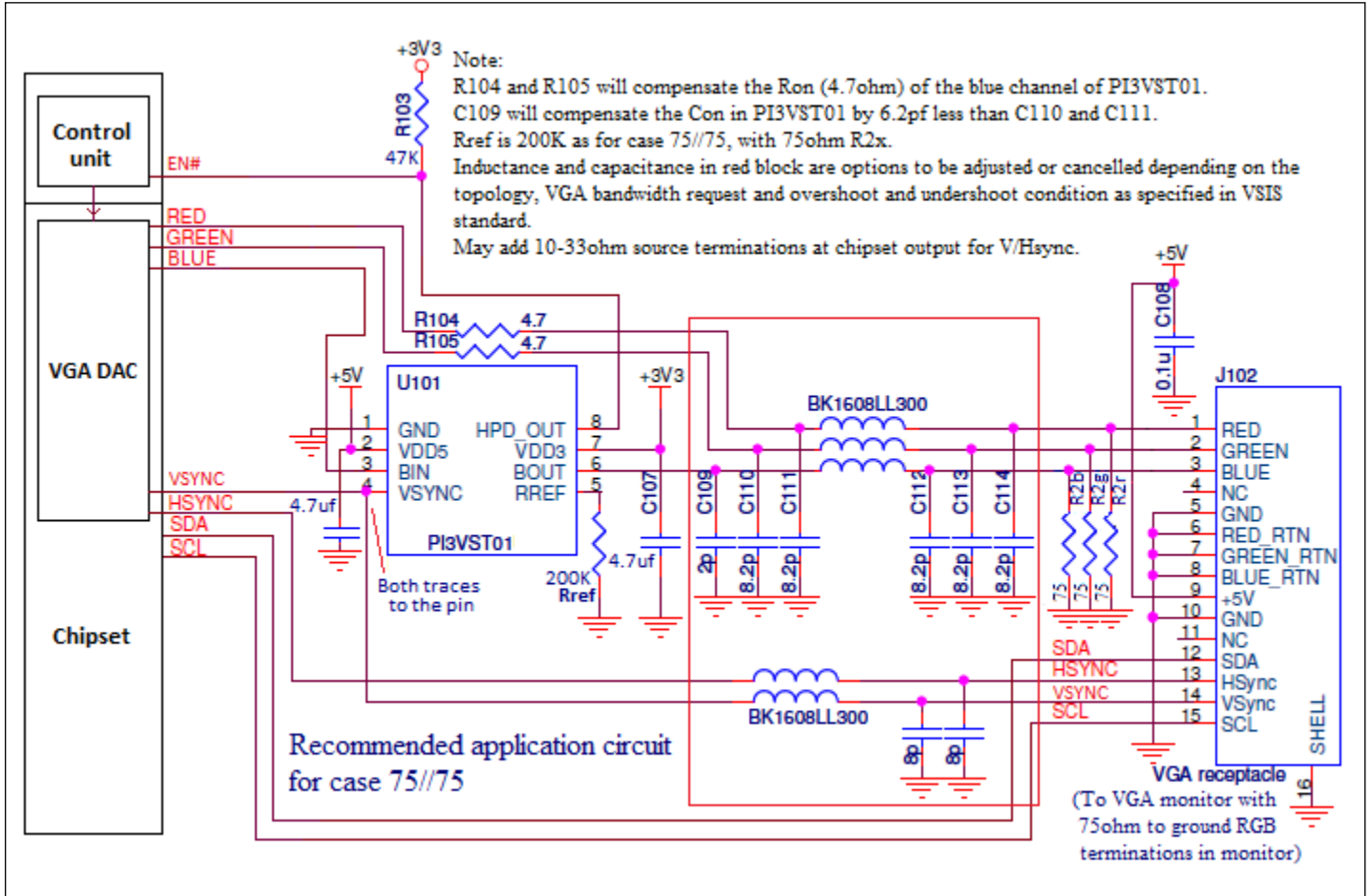

Total power dissipation of this solution is very small. PI3VST01 power dissipation is 0.66 mW typical, which is a small fraction (<1%) of the 170 mW saved when the monitor is not connected.

### Packaging Mechanical: 8-Pin MSOP (U)

PKG. DIMENSIONS(MM)		
SYMBOL	Min.	Max.
A	–	1.10
A1	0.00	0.15
A2	0.75	0.95
b	0.22	0.38
c	0.08	0.23
D	2.90	3.10
E	2.90	3.10
E1	4.65	5.15
e	0.65 BSC	
L	0.40	0.80
θ	0°	8°

**PERICOM**  
Enabling Serial Connectivity

DATE: 10/20/14

DESCRIPTION: 8-Pin, Mini Small Outline Package, MSOP

PACKAGE CODE: U (U8)

DOCUMENT CONTROL #: PD-1261

REVISION: E

**NOTE:**  
 1. ALL DIMENSIONS ARE IN MILLIMETERS.  
 2. REFER JEDEC MO-187E/AA  
 3. PACKAGE OUTLINE DIMENSIONS DO NOT INCLUDE MOLD FLASH AND METAL BURR.

Please check for the latest package information on the Pericom web site at [www.pericom.com/packaging/](http://www.pericom.com/packaging/)

### Ordering Information

Ordering Code	Package Code	Package Description
PI3VST01UE	U	8-pin, Mini Small Outline Package (MSOP)
PI3VST01UEX	U	8-pin, Mini Small Outline Package (MSOP), Tape & Reel

- Thermal characteristics can be found on the company web site at [www.pericom.com/packaging/](http://www.pericom.com/packaging/)
- E = Pb-free and Green
- X suffix = Tape/Reel