



Chipsmall Limited consists of a professional team with an average of over 10 year of expertise in the distribution of electronic components. Based in Hongkong, we have already established firm and mutual-benefit business relationships with customers from,Europe,America and south Asia,supplying obsolete and hard-to-find components to meet their specific needs.

With the principle of "Quality Parts,Customers Priority,Honest Operation,and Considerate Service",our business mainly focus on the distribution of electronic components. Line cards we deal with include Microchip,ALPS,ROHM,Xilinx,Pulse,ON,Everlight and Freescale. Main products comprise IC,Modules,Potentiometer,IC Socket,Relay,Connector.Our parts cover such applications as commercial,industrial, and automotives areas.

We are looking forward to setting up business relationship with you and hope to provide you with the best service and solution. Let us make a better world for our industry!



Contact us

Tel: +86-755-8981 8866 Fax: +86-755-8427 6832

Email & Skype: info@chipsmall.com Web: www.chipsmall.com

Address: A1208, Overseas Decoration Building, #122 Zhenhua RD., Futian, Shenzhen, China



Features

- Low output skew: <200ps
- Switching frequency up to 166 MHz
- Fast output rise/fall time: <1.0ns
- Low propagation delay: <2.5ns
- Low input capacitance: <6.0pF
- Balanced CMOS outputs
- Industrial Temperature: -40°C to +85°C
- 3.3V ±10% operation, 5V Input Tolerant
- Packaging (Pb-free & Green available):
 - 20-pin 150-mil wide QSOP (Q)
 - 20-pin 209-mil wide SSOP (H)

Description

Pericom Semiconductor's PI49FCT3805D is composed of non-inverting drivers. The outputs are configured into 2 groups of one-in, five-out with independent output enable. Group B has an extra MON output. Excellent output signals to power and ground ratio minimize power and ground noise and also improves output performance.

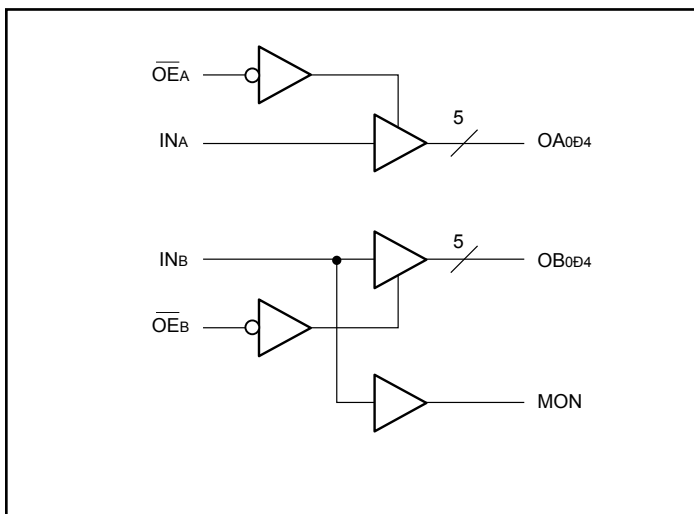
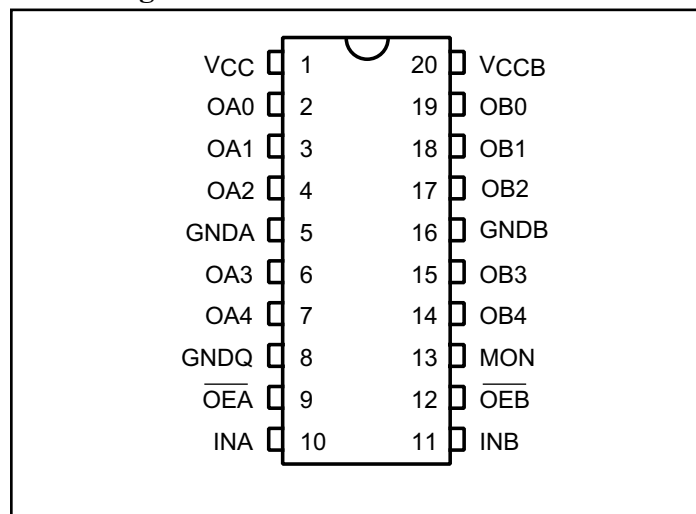
Block Diagram

Pin Configuration

Pin Description

Pin Name	Description
\overline{OE}_X	Hi-Z State Output Enable Inputs (Active Low)
IN_X	Clock Inputs
OA_N, OB_N	Clock Outputs
MON	Monitor Output
GND	Ground
V _{CC}	Power

Truth Table⁽¹⁾

Inputs		Outputs	
\overline{OE}_X	IN_X	OA_X	MON
L	L	L	L
L	H	H	H
H	L	Z	L
H	H	Z	H

Note:

1. H = High Voltage Level, L = Low Voltage Level, Z = High Impedance

Maximum Ratings

(Above which the useful life may be impaired. For user guidelines, not tested.)

Storage Temperature	-65°C to +150°C
Ambient Temperature with Power Applied	-40°C to +85°C
Input Voltage to GND Potential (Inputs & V _{CC} Only)	-0.5V to 5.5V
Output Voltage to GND Potential (Outputs & I/O Only)...	-0.5V to +V _{CC} +0.5V
V _{CC} Input Voltage.....	-0.5V to +4.6V

Note:

Stresses greater than those listed under MAXIMUM RATINGS may cause permanent damage to the device. This is a stress rating only and functional operation of the device at these or any other conditions above those indicated in the operational sections of this specification is not implied. Exposure to absolute maximum rating conditions for extended periods may affect reliability.

DC Electrical Characteristics (T_A = -40°C to +85°C, V_{CC} = 3.3V ± 0.3V)

Symbol	Parameters	Test Conditions ⁽¹⁾	Min.	Typ.	Max.	Units
V _{OH}	Output High Voltage V _{CC} = Min., V _{IN} = V _{IL} or V _{IH}	I _{OH} = -0.1mA I _{OH} = -8mA I _{OH} = -12mA	V _{CC} -0.2 2.4 ⁽³⁾ 2.4 ⁽³⁾	- 3.0 3.0		V
V _{OL}	Output Low Voltage V _{CC} = Min., V _{IN} = V _{IL} or V _{IH}	I _{OH} = 0.1mA I _{OH} = 8mA I _{OH} = 12mA		- 0.2 0.3	0.2 0.4 0.4	
V _{IH}	Input High Voltage	Low Logic	2.0		5.5	
V _{IL}	Input Low Voltage	High Logic	-0.5		0.8	
I _{IH}	Input High Current	V _{CC} = Max., V _{IN} = 5.5V			1	μA
I _{IL}	Input Low Current	V _{CC} = Max., V _{IN} = GND			-1	
I _{OZH} I _{OZL}	High Impedance output current	V _{CC} = Max., all outputs disabled			1 -1	
V _{IK}	Clamp Diode Voltage	V _{CC} = Min., I _{IN} = -18mA		-0.7	-1.2	V
I _{ODH}	Output High Current ^(4, 5)	V _{OUT} = 1.5V, V _{IN} = V _{IL} or V _{IH} , V _{CC} = 3.3V	-40	-74	-100	mA
I _{ODL}	Output Low Current ^(4, 5)	V _{OUT} = 1.5V, V _{IN} = V _{IL} or V _{IH} , V _{CC} = 3.3V	50	90	130	
I _{OS}	Short Circuit Current ^(4, 5)	V _{CC} = Max., V _{OUT} = GND	-60	-100	-120	

Notes:

1. For Max. or Min. conditions, use appropriate value specified under Electrical Characteristics for the applicable device type.
2. Typical values are at V_{CC} = 3.3V, +25°C ambient and maximum loading.
3. V_{OH} = V_{CC} - 0.6V at rated current.
4. This parameter is determined by device characterization but is not production tested.
5. Not more than one output should be shorted at one time. Duration of the test should not exceed one second.

Capacitance ($T_A = 25^\circ\text{C}$, $f = 1\text{ MHz}$)

Parameters ⁽¹⁾	Description	Test Conditions	Typ	Max.	Units
C_{IN}	Input Capacitance	$V_{IN} = 0\text{V}$	3.0	4	pF
C_{OUT}	Output Capacitance	$V_{OUT} = 0\text{V}$	—	6	

Note:

- This parameter is determined by device characterization but is not production tested.

Power Supply Characteristics

Parameters	Description	Test Conditions ⁽¹⁾		Min.	Typ. ⁽²⁾	Max.	Units
I_{CC}	Quiescent Power Supply Current	$V_{CC} = \text{Max.}$	$V_{IN} = \text{GND or } V_{DD}$		0.1	30	μA
I_{DD}	Dynamic Supply Current per Output	$V_{CC} = 3.6\text{V}$, $C_L = 15\text{pF}$, All Outputs Toggling			80	120	
I_C	Total Power Supply Current	$V_{CC} = 3.6\text{V}$, $C_L = 15\text{pF}$, All Outputs Toggling, $f_i = 133\text{ MHz}$	$V_{IN} = V_{CC} \text{ or GND}$		100	135	mA/ MHz
			$V_{IN} = V_{CC} - 0.6\text{V or GND}$		100	135	
		$V_{CC} = 3.6\text{V}$, $C_L = 15\text{pF}$, All Outputs Toggling, $f_i = 166\text{ MHz}$	$V_{IN} = V_{CC} \text{ or GND}$		120	160	
			$V_{IN} = V_{CC} - 0.6\text{V or GND}$		120	160	
ΔI_{CC}	Supply Current per inputs @ TTL High	$V_{CC} = \text{Max.}$	$V_{IN} = V_{CC} - 0.6\text{V}^{(3)}$		45	300	μA

Notes:

- For Max. or Min. conditions, use appropriate value specified under Electrical Characteristics for the applicable device.
- Typical values are at $V_{CC} = 3.3\text{V}$, $+25^\circ\text{C}$ ambient.
- Per TTL driven input ($V_{IN} = V_{CC} - 0.6\text{V}$); all other inputs at V_{CC} or GND.

Switching Characteristics over Operating Range

Parameters	Description	Test Conditions ⁽¹⁾	3805D	Units	
			Max.		
t _{PLH} t _{PHL}	Propagation Delay I _N to O _N	C _L = 15pF, 133 MHz (3805D)	3.0		
t _R /t _F	CLKn Rist/Fall Time 0.8V ~ 2.0V		1.5	ns	
t _{SK(o)} ⁽³⁾	Pulse Skew		270	ps	
t _{SK(p)} ⁽³⁾	Output Skew		270		
t _{SK(t)} ⁽³⁾	Package Skew		550		
t _{ZL} , t _{ZH} , t _{LZ} , t _{HZ}	Enable/Disable Time			5.2	ns
F _{MAX}	Input Frequency			133	MHz

Note:

1. These parameters are guaranteed by design
2. Series Resistor loading = 33Ω (See Test Circuit)

Switch Position

Test	Switch
Disable LOW Enable LOW	6V
Disable HIGH Enable HIGH	GND
All Other Inputs	Open

Definitions:

1. C_L = Load capacitance: includes jig and probe capacitance.
2. R_T = Termination resistance: should be equal to Z_{OUT} of the Pulse Generator.

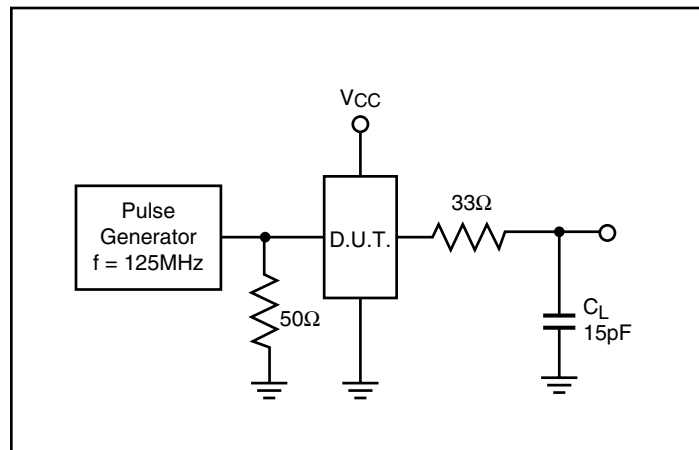
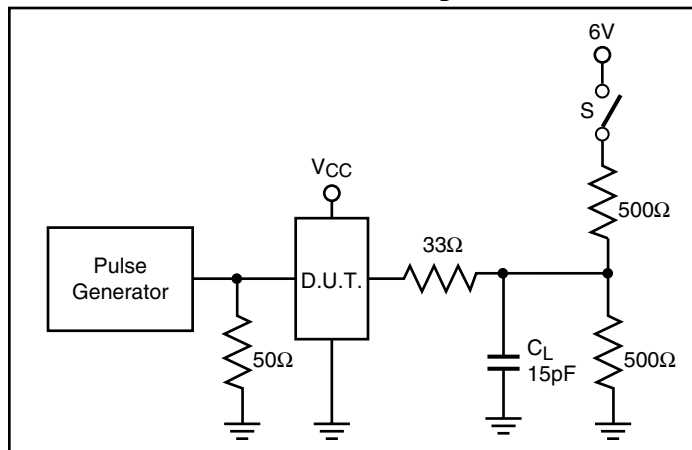
Tests Circuit

Enable/Disable Time Test Set-Up

Switching Waveforms

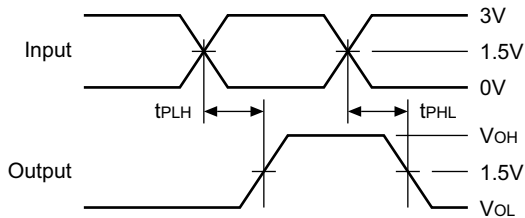
Propagation Delay

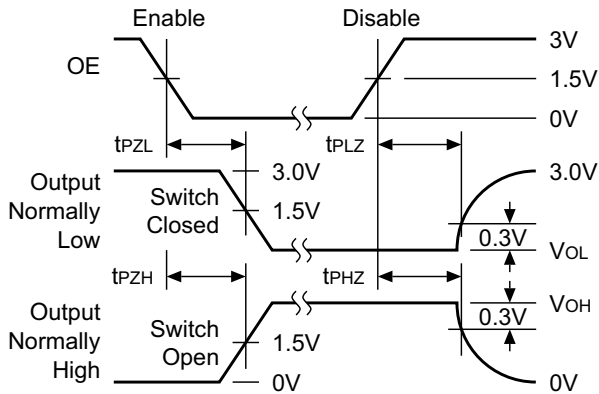

Enable and Disable Times



Package Skew – t_{SK(t)}

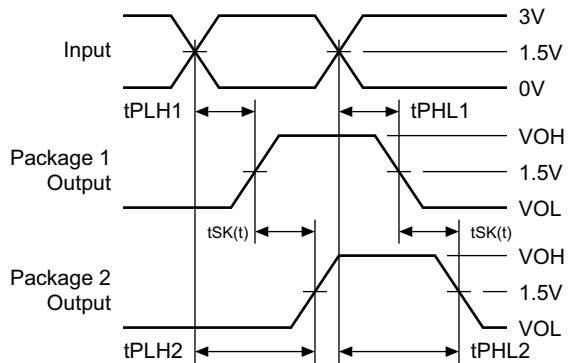

$$t_{SK(t)} = |t_{PLH2} \ominus t_{PLH1}| \text{ or } |t_{PHL2} \ominus t_{PHL1}|$$

Output Skew – t_{SK(o)}

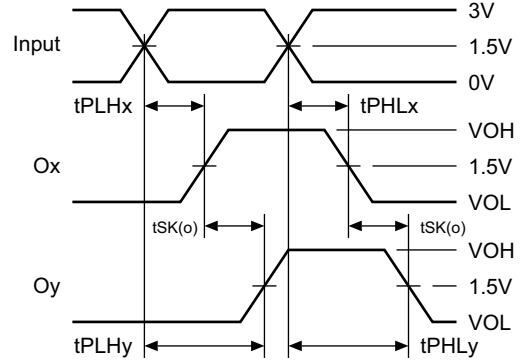

$$t_{SK(o)} = |t_{PLHy} \ominus t_{PLHx}| \text{ or } |t_{PHLy} \ominus t_{PHLx}|$$

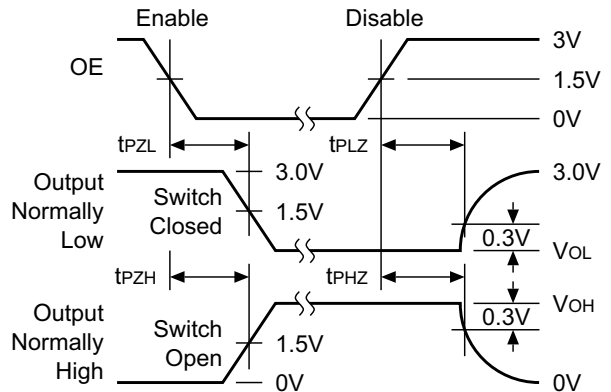

Pulse Skew – t_{SK(p)}

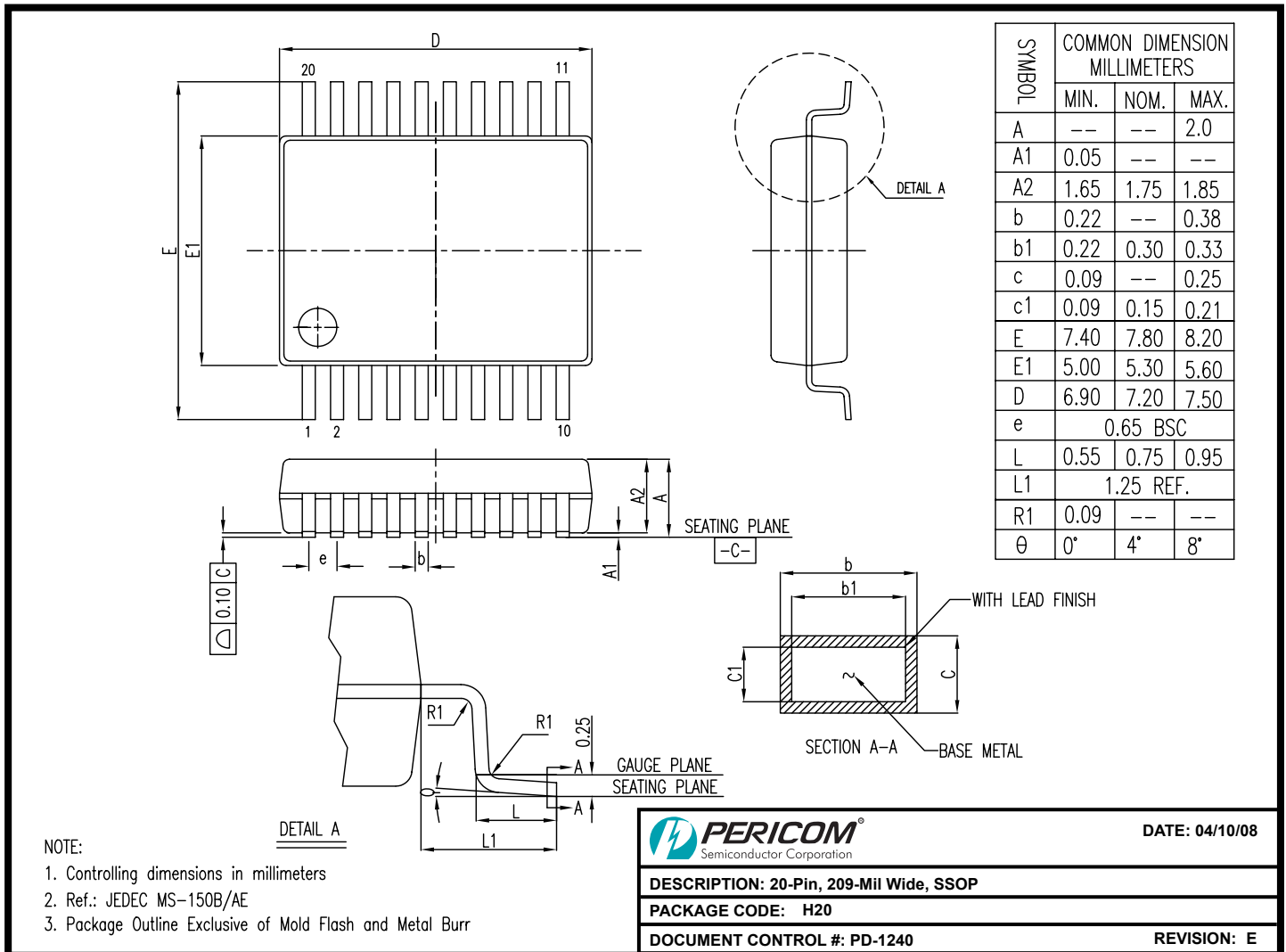

Packaging Mechanical: 20-Pin 209-mil wide SSOP (H)

08-0140

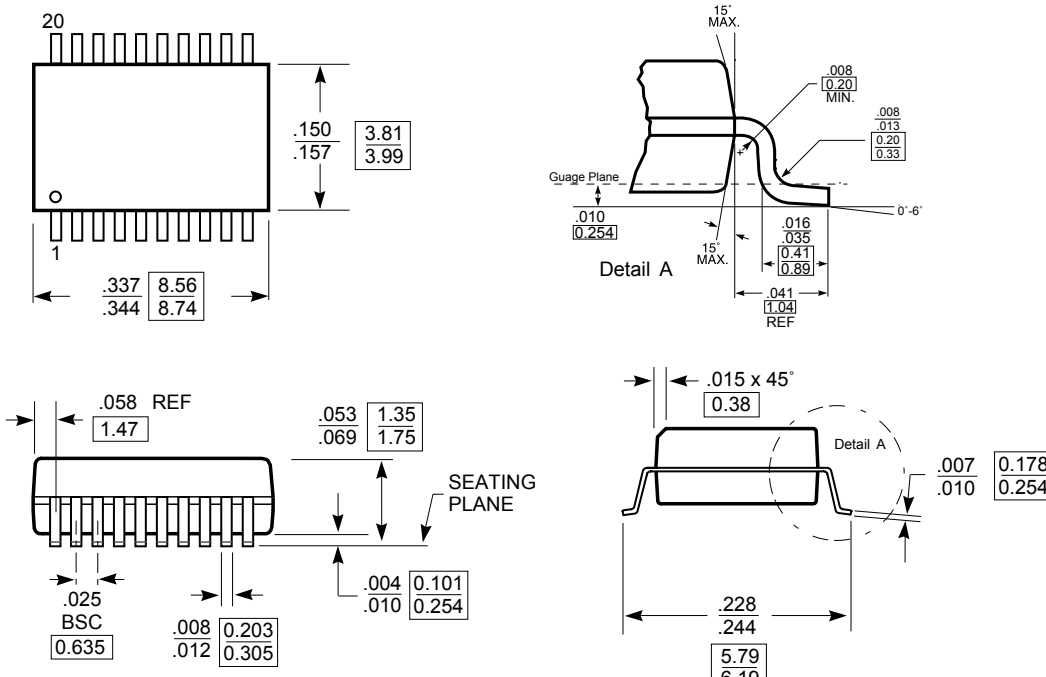
Packaging Mechanical: 20-Pin 150-mil wide QSOP (Q)

 <p>X.XX DENOTES DIMENSIONS X.XX IN MILLIMETERS</p> <p>Note: 1) Controlling dimensions in inches. 2) Ref: JEDEC MO-137B/AD 3) Dimensions do not include mold flash, protrusions or gate burrs</p>	<p>DOCUMENT CONTROL NO. PD - 1202</p> <p>REVISION: H DATE: 10/22/07</p>
 <p>Pericom Semiconductor Corporation 3545 N. 1st Street, San Jose, CA 95134 1-800-435-2335 • www.pericom.com</p>	
<p>DESCRIPTION: 20-Pin, 150-Mil Wide, QSOP</p>	
<p>PACKAGE CODE: Q</p>	

Ordering Information

Ordering Code	Package Code	Package Description
PI49FCT3805DHE	H	Pb-free & Green, 20-pin 209-mil SSOP
PI49FCT3805DQE	Q	Pb-free & Green, 20-pin 150-mil QSOP

Notes:

1. Thermal characteristics can be found on the company web site at www.pericom.com/packaging/
2. Number of Transistors = TBD