



Chipsmall Limited consists of a professional team with an average of over 10 year of expertise in the distribution of electronic components. Based in Hongkong, we have already established firm and mutual-benefit business relationships with customers from,Europe,America and south Asia,supplying obsolete and hard-to-find components to meet their specific needs.

With the principle of “Quality Parts,Customers Priority,Honest Operation,and Considerate Service”,our business mainly focus on the distribution of electronic components. Line cards we deal with include Microchip,ALPS,ROHM,Xilinx,Pulse,ON,Everlight and Freescale. Main products comprise IC,Modules,Potentiometer,IC Socket,Relay,Connector.Our parts cover such applications as commercial,industrial, and automotives areas.

We are looking forward to setting up business relationship with you and hope to provide you with the best service and solution. Let us make a better world for our industry!



Contact us

Tel: +86-755-8981 8866 Fax: +86-755-8427 6832

Email & Skype: info@chipsmall.com Web: www.chipsmall.com

Address: A1208, Overseas Decoration Building, #122 Zhenhua RD., Futian, Shenzhen, China



Low-voltage translating 8-bit I²C-bus I/O Expander**Features**

- Operation power supply voltage from 1.65V to 4.0V
- Allows bidirectional voltage-level translation and GPIO expansion between:
 - 1.8 V SCL/SDA and 1.8 V, 2.5 V, 3.3 V Port P
 - 2.5 V SCL/SDA and 1.8 V, 2.5 V, 3.3 V Port P
 - 3.3 V SCL/SDA and 1.8 V, 2.5 V, 3.3 V Port P
- Low standby current consumption:
 - 1.5 μ A typical at 3.3 V V_{DD}
- 1MHz I²C-bus interface
- Compliant with the I²C-bus Fast and Standard modes
- Programmable Pull-up/Pull-down Resistors for GPIO Inputs
- Software Reset
- Active LOW open-drain interrupt output
- Low standby current
- Latch-up tested (exceeds 100mA)
- Offered in UQFN1.8x2.6-16

Description

The PI4IOE5V6408 is an 8-bit general-purpose I/O expander that provides remote I/O expansion for most microcontroller families via the I²C-bus interface.

It provides a simple solution when additional I/Os are needed while keeping interconnections to a minimum, for example, in battery-powered mobile applications for interfacing to sensors, push buttons, keypad, etc.

It can operate from 1.65 V to 4 V on the GPIO-port side and 1.65 V to 3.6 V on the SDA/SCL side. This allows the PI4IOE5V6408 to interface with next generation microprocessors and microcontrollers on the SDA/SCL side, where supply levels are dropping down to conserve power.

The bidirectional voltage-level translation in the PI4IOE5V6408 is provided through $V_{DD(I2C_bus)}$. $V_{DD(I2C_bus)}$ should be connected to the V_{DD} of the external SCL/SDA lines. The voltage level on the GPIO-port of the PI4IOE5V6408 is determined by $V_{DD(P)}$.

At power on, the I/Os are configured as inputs; however, the system master can enable the I/Os as either inputs or outputs by writing to the I/O direction bits. The data for each input or output is kept in the corresponding Input or Output register. All registers can be read by the system master.

PI4IOE5V6408 has open-drain interrupt (\overline{INT}) output pin that goes LOW when the input state of a GPIO-port changes from the input-state default register value. The device also has an interrupt masking feature by which the user can mask the interrupt from an individual GPIO-port.

Pin Configuration

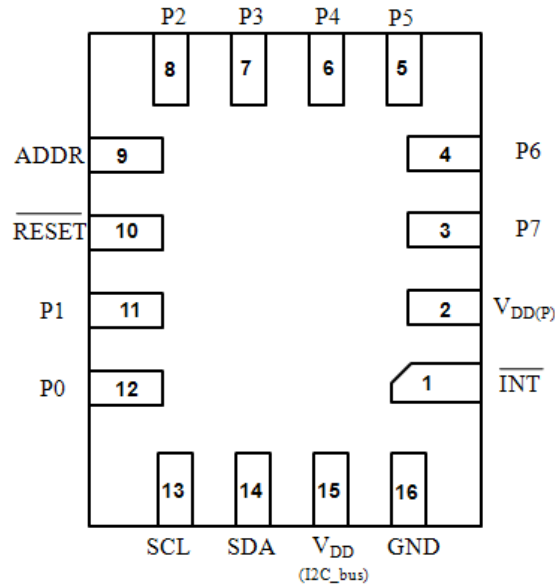

Fig 1. UQFN Top View

Pin Description

Table 1: Pin Description

Pin Name	Pin No.	Description
$\overline{\text{INT}}$	1	Active-low interrupt output. Connect to $V_{\text{DD(I2C_bus)}}$ through a pull-up resistor.
$V_{\text{DD(P)}}$	2	Supply voltage of PI4IOE5V6408 GPIO-port
P7	3	GPIO-port input/output (push-pull design structure). At power on, P7 is configured as an input.
P6	4	GPIO-port input/output (push-pull design structure). At power on, P6 is configured as an input.
P5	5	GPIO-port input/output (push-pull design structure). At power on, P5 is configured as an input.
P4	6	GPIO-port input/output (push-pull design structure). At power on, P4 is configured as an input.
P3	7	GPIO-port input/output (push-pull design structure). At power on, P3 is configured as an input.
P2	8	GPIO-port input/output (push-pull design structure). At power on, P2 is configured as an input.
ADDR	9	Address input. Connect directly to $V_{\text{DD(I2C_bus)}}$ or ground.
$\overline{\text{RESET}}$	10	Active-low reset input. Connect to $V_{\text{DD(I2C_bus)}}$ through a pull-up resistor, if no active connection is used.
P1	11	GPIO-port input/output (push-pull design structure). At power on, P1 is configured as an input.
P0	12	GPIO-port input/output (push-pull design structure). At power on, P0 is configured as an input.
SCL	13	Serial clock bus. Connect to $V_{\text{DD(I2C_bus)}}$ through a pull-up resistor.
SDA	14	Serial data bus. Connect to $V_{\text{DD(I2C_bus)}}$ through a pull-up resistor.
$V_{\text{DD(I2C_bus)}}$	15	Supply voltage of I ² C bus.
GND	16	Ground

Maximum Ratings

Power supply.....	-0.5V to +4.6V
Voltage on an I/O pin (Input / Output).....	-0.5V to +4.0V
Input current.....	±20mA
Output current on an I/O pin	±50mA
Supply current.....	±100mA
Ground supply current.....	±100mA
Operation temperature.....	-40~85°C
Storage temperature	-65~150°C
Maximum junction temperature, T _j (max)	125°C
ESD (HBM)	2kV

Note:

Stresses greater than those listed under MAXIMUM RATINGS may cause permanent damage to the device. This is a stress rating only and functional operation of the device at these or any other conditions above those indicated in the operational sections of this specification is not implied. Exposure to absolute maximum rating conditions for extended periods may affect reliability.

Recommended Operating Conditions

Table 2: Recommended operating conditions

Symbol	Parameter	Conditions	Min.	Typ.	Max.	Unit
V _{DD(IC-bus)}	I ² C-bus supply voltage		1.65	-	3.6	V
V _{DD(P)}	GPIO port supply voltage		1.65	-	4	V
V _{IN}	Input voltage on IO pins		0		4	V
V _{OUT}	Output Voltage		0		V _{DD(P)}	V

Static Characteristics

$V_{DD(I2C_bus)} = 1.8\text{ V to }3.6\text{ V}$; $GND = 0\text{ V}$; Temp = $-40\text{ }^{\circ}\text{C to }+85\text{ }^{\circ}\text{C}$; unless otherwise specified.

Typical values are at Temp = $25\text{ }^{\circ}\text{C}$.

Table 3: Static characteristics

Symbol	Parameter	Condition	Min.	Typ. ^[1]	Max.	Unit
Power supply						
$I_{DD}^{[2]}$	Supply current	$V_{DD(I2C_bus)} = 1.8\text{ to }3.6\text{ V}$; Standby mode V_I on SDA, ADDR and $\overline{\text{RESET}}$ = $V_{DD(I2C_bus)}$ or GND; V_I on P port = $V_{DD(P)}$ or GND; $I_O = 0\text{ mA}$; I/O = inputs; $f_{SCL} = 0\text{ kHz}$	-	1.2	1.5	μA
		$V_{DD(I2C_bus)} = 1.8\text{ to }3.6\text{ V}$; Active mode V_I on $\overline{\text{RESET}} = V_{DD(I2C_bus)}$; V_I on P port = $V_{DD(P)}$ or GND; $I_O = 0\text{ mA}$; I/O = inputs; $f_{SCL} = 400\text{ kHz}$, continuous register read	-	-	300	μA
I_{OFF}	Power off leakage current			-	10	μA
I_{IN}	Input leakage current	$0 \leq V_{IN} \leq V_{DD(I2C_bus)}$	-10	-	10	μA
V_{POR}	Power-on reset voltage		-	-	1.25	V
Input SCL, input/output SDA						
V_{IL}	Low level input voltage		-0.5	-	$\frac{0.3}{V_{DD(I2C_bus)}}$	V
V_{IH}	High level input voltage		$\frac{0.7}{V_{DD(I2C_bus)}}$	-	3.6	V
I_{OL}	Low level output current	$V_{OL} = 0.4\text{ V}$	20	-	-	mA
I_L	Leakage current	$V_{IN} = V_{DD(I2C_bus)}$ or GND	-10	-	10	μA
C_i	Input capacitance	$V_{IN} = GND$	-	5	10	pF
Interrupt $\overline{\text{INT}}$						
I_{OL}	Low level output current	$V_{OL} = 0.4\text{ V}$	6		-	mA
C_o	Output capacitance			2.1	10	pF
Select inputs ADDR and $\overline{\text{RESET}}$						
V_{IL}	Low level input voltage		-0.5	-	$\frac{0.3}{V_{DD(I2C_bus)}}$	V
V_{IH}	High level input voltage		$\frac{0.7}{V_{DD(I2C_bus)}}$	-	3.6	V
I_L	Input leakage current		-1		1	μA
C_i	Input capacitance			2.4	10	pF

Static Characteristics Cont.

Symbol	Parameter	Condition	Min.	Typ. ^[1]	Max.	Unit
I/Os						
V_{IL}	Low-level input voltage	P0 – P7	-0.5	-	+0.3* $V_{DD(P)}$	V
V_{IH}	High-level input voltage	P0 – P7	0.7* $V_{DD(P)}$	-	4.0	V
V_{OH}	High-level output voltage	P port; $I_{OH} = -100 \mu\text{A}$;				
		$V_{DD(P)} = 1.8 \text{ V}$	$V_{DD(P)} - 0.2$	-	-	V
		$V_{DD(P)} = 3.6 \text{ V}$	$V_{DD(P)} - 0.2$	-	-	V
		$V_{DD(P)} = 4.0 \text{ V}$	$V_{DD(P)} - 0.2$	-	-	V
		P port; $I_{OH} = -6 \text{ mA}$				
		$V_{DD(P)} = 1.8 \text{ V}$	$V_{DD(P)} - 0.2$	-	-	V
		$V_{DD(P)} = 3.6 \text{ V}$	$V_{DD(P)} - 0.2$	-	-	V
V_{OL}	Low-level output voltage	P port; $I_{OL} = 100 \mu\text{A}$;				
		$V_{DD(P)} = 1.8 \text{ V}$	-	-	0.2	V
		$V_{DD(P)} = 3.6 \text{ V}$	-	-	0.2	V
		$V_{DD(P)} = 4.0 \text{ V}$	-	-	0.2	V
		P port; $I_{OL} = 6 \text{ mA}$				
		$V_{DD(P)} = 1.8 \text{ V}$	-	-	0.5	V
		$V_{DD(P)} = 3.6 \text{ V}$	-	-	0.45	V
I_{OL}	Low-level output current	P0 – P7	6.0	-	-	mA
I_{OH}	High-level output current	P0 – P7	-6.0	-	-	mA
$I_{IH}^{[3]}$	High-level input current	P port; $V_I = V_{DD(P)}$; $V_{DD(P)} = 1.65 \text{ V to } 4.0 \text{ V}$	-50	-	50	μA
$I_{IL}^{[3]}$	Low-level input current	P port; $V_I = \text{GND}$; $V_{DD(P)} = 1.65 \text{ V to } 4.0 \text{ V}$	-50	-	50	μA
$R_{pu(int)}$	Internal pull-up resistance	Input/Output	-	100	-	k Ω
$R_{pd(int)}$	Internal pull-down resistance	Input/Output	-	100	-	k Ω

Note:

 [1] Includes all internal circuitry consumption from the $V_{DD(12C_bus)}$ supply. Does not include the I/O buffers, which are supplied by $V_{DD(P)}$ and are load dependent.

 [2] I_{IL} and I_{IH} specifications only apply when the outputs are configured with pull-down or pull-up resistors, respectively. Specification value assume $V_{IN} \leq V_{DD(P)}$

Dynamic Characteristics

Table 4: Dynamic characteristics

Symbol	Parameter	Standard mode I ² C		Fast mode I ² C		Fast mode Plus I ² C		Unit
		Min	Max	Min	Max	Min	Max	
f _{SCL}	SCL clock frequency	0	100	0	400	0	1000	kHz
t _{BUF}	Bus free time between a STOP and START condition	4.7	-	1.3	-	0.5	-	μs
t _{HD;STA}	Hold time (repeated) START condition	4.0	-	0.6	-	0.26	-	μs
t _{SU;STA}	Set-up time for a repeated START condition	4.7	-	0.6	-	0.26	-	μs
t _{SU;STO}	Set-up time for STOP condition	4.0	-	0.6	-	0.26	-	μs
t _{VD;ACK} ^[1]	Data valid acknowledge time	-	3.45	-	0.9	-	0.45	μs
t _{HD;DAT} ^[2]	Data hold time	0	-	0	-	0	-	ns
t _{VD;DAT}	Data valid time	-	3.45	-	0.9	-	0.45	ns
t _{SU;DAT}	Data set-up time	250	-	100	-	50	-	ns
t _{LOW}	LOW period of the SCL clock	4.7	-	1.3	-	0.5	-	μs
t _{HIGH}	HIGH period of the SCL clock	4.0	-	0.6	-	0.26	-	μs
t _f	Fall time of both SDA and SCL signals	-	300	-	300	-	120	ns
t _r	Rise time of both SDA and SCL signals	-	1000	-	300	-	120	ns
t _{SP}	Pulse width of spikes that must be suppressed by the input filter	-	50	-	50	-	50	ns
Interrupt timing								
t _{V(INT)}	Valid time on pin $\overline{\text{INT}}$	-	4	-	4	-	4	μs
Reset timing								
t _{w(rst)}	Reset pulse width	150	-	150	-	150	-	ns
t _{rst_glitch}	Reset recovery time ^[4]	50	150	50	150	50	150	ns
t _{rst}	Reset time	-	150	-	150	-	150	ns

Note:

 [1]: t_{VD;ACK} = time for acknowledgement signal from SCL LOW to SDA (out) LOW.

 [2]: t_{VD;DAT} = minimum time for SDA data out to be valid following SCL LOW.

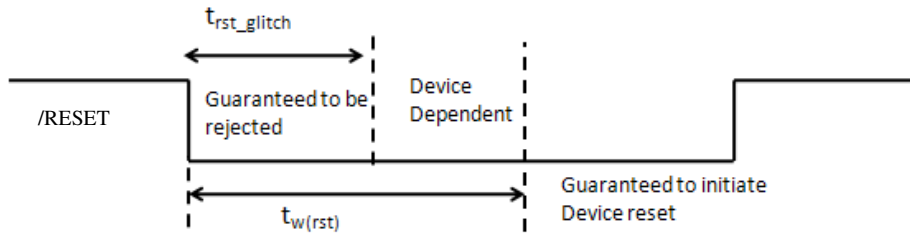

Fig 2: Reset Pulse Duration and Input Glitch Rejection Timing Diagram

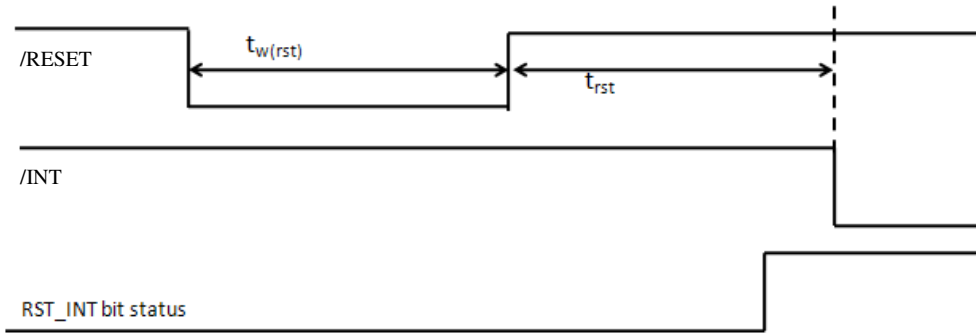

Fig 3: Reset Pulse Duration and Input Glitch Rejection Timing Diagram

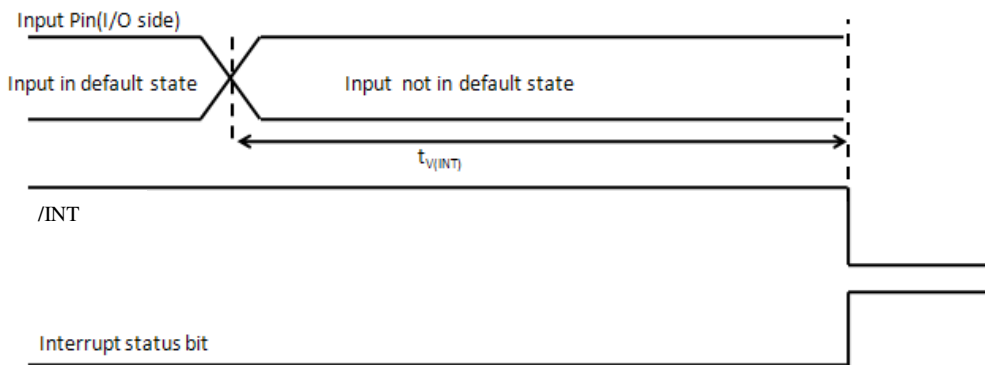

Fig 4: Time to \overline{INT} from Change in Input Default State

PI4IOE5V6408 Block Diagram

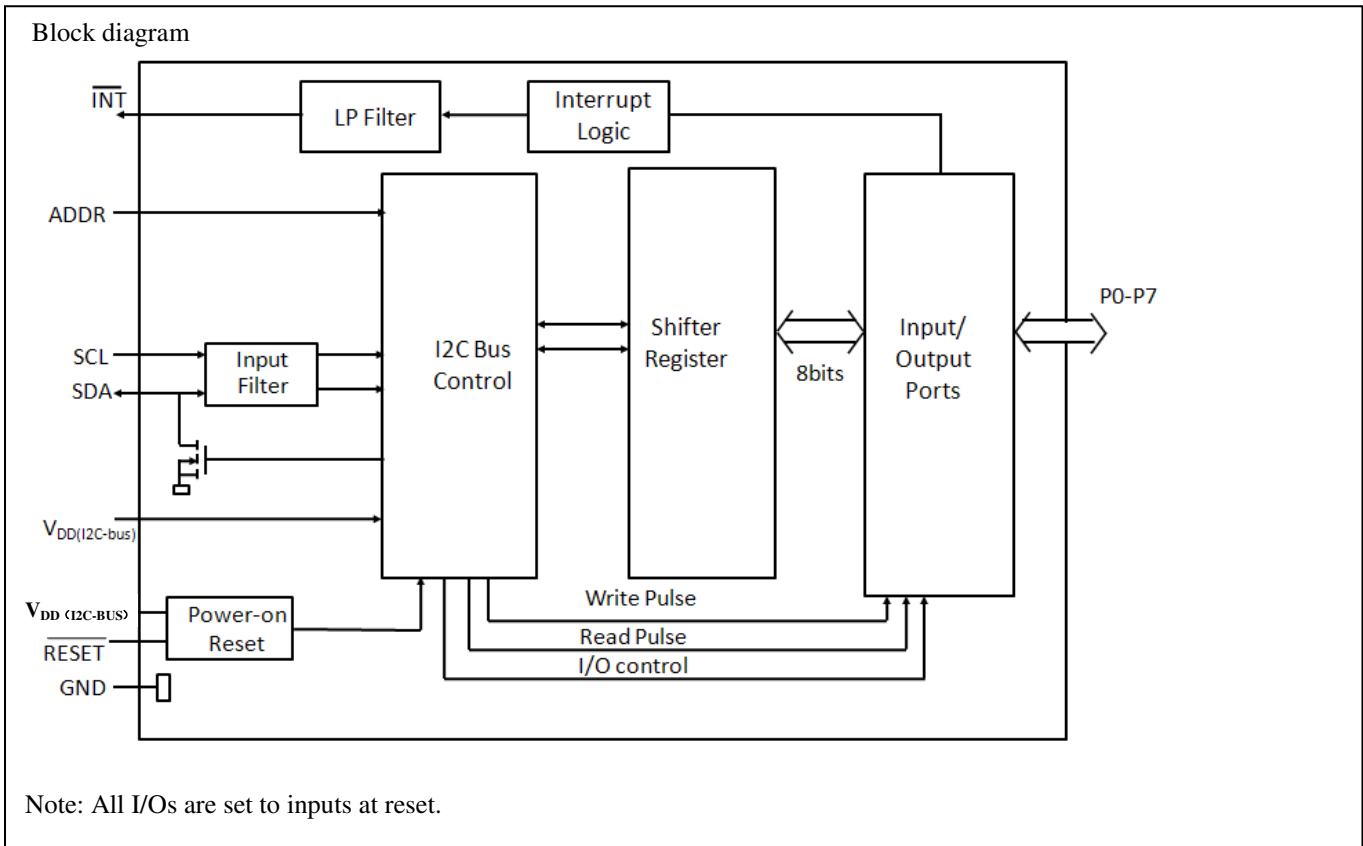

Fig 5: Block diagram

Functional Description

a. Device Address

The address of the device is shown below in Table 5. Setting ADDR pin to GND (0) results in B[3:1] bits set as 011, and setting ADDR pin to $V_{DD(I2C_{bus})}$ (1) results in B[3:1] bits set as 100.

Table 5: Device address

ADDR	B7 (MSB)	B6	B5	B4	B3	B2	B1	B0
0	1	0	0	0	0	1	1	R / W
1	1	0	0	0	1	0	0	R / W

The last bit of the device address defines the operation to be performed. A logic 1 selects a read operation, while a logic 0 selects a write operation.

b. Register Map

Following the successful acknowledgment of the address byte, the bus master sends a command byte, which is stored in the Pointer Register in the PI4IOE5V6408. Five bits of this data byte state the operation (read or write) and the internal registers that will be affected. This register can be written or read through the I²C bus. The command byte is sent only during a write transmission.

Table 6: Register Map

Pointer Register Bits								Command byte (hexadecimal)	Register	Protocol	Power-up default
B7	B6	B5	B4	B3	B2	B1	B0				
0	0	0	0	0	0	0	1	01h	Device ID and Control	R/W	1010 0010
0	0	0	0	0	0	1	1	03h	I/O Direction	R/W	0000 0000
0	0	0	0	0	1	0	1	05h	Output State	R/W	0000 0000
0	0	0	0	0	1	1	1	07h	Output High-impedance	R/W	1111 1111
0	0	0	0	1	0	0	1	09h	Input Default State	R/W	0000 0000
0	0	0	0	1	0	1	1	0Bh	Pull-up/down Enable	R/W	1111 1111
0	0	0	0	1	1	0	1	0Dh	Pull-up/down Select	R/W	0000 0000
0	0	0	0	1	1	1	1	0Fh	Input Status	R	xxxx xxxx
0	0	0	1	0	0	0	1	11h	Interrupt Mask	R/W	0000 0000
0	0	0	1	0	0	1	1	13h	Interrupt Status	R/W	xxxx xxxx
								02h, 04h, 06h, 08h, 0Ah, 0Ch, 0Eh, 10h, 12h	Reserved	R/W	

c. Register Descriptions

i. Register 01h : Device ID and Control

The Device ID and Control register contains the manufacturer ID and firmware revision. The Control register indicates whether the device has been reset and the default values have been set.

- The Reset Interrupt is set B1 = 1 when the device is either reset by the RESET pin, a power on reset, or software reset.
- Reset Interrupt is then cleared after being read by the master.
- A software reset is issued when the master writes B0=1.
- When reading from B0, the value read will always be 0.

Table 7: Device ID and Control register (address 01h)

Bit	B7	B6	B5	B4	B3	B2	B1	B0
Name	Manufacture ID			Firmware Revision			Reset interrupt	Software reset
Default	1	0	1	0	0	0	1	R / W

ii. Register 03h : I/O Direction

The I/O Direction Register configures the direction of the I/O pins.

- If a bit in this register is set to 0, the corresponding port pin is enabled as an input
- If a bit in this register is set to 1, the corresponding port pin is enabled as an output.

Table 8: I/O Direction register (address 03h)

Bit	B7	B6	B5	B4	B3	B2	B1	B0
Name	P7	P6	P5	P4	P3	P2	P1	P0
Default	0	0	0	0	0	0	0	0

iii. Register 05h : Output Port Register

The Output Port Register sets the outgoing logic levels of the pins defined as outputs.

- When Bx is set to 0, Px = L; When Bx is set to 1, Px = H
- Bit values in this register have no effect on pins defined as inputs
- Reads from this register reflect the value that is in the flip-flop controlling the output selection, not the actual pin value.

Table 9: Output Port Register (address 05h)

Bit	B7	B6	B5	B4	B3	B2	B1	B0
Name	P7	P6	P5	P4	P3	P2	P1	P0
Default	0	0	0	0	0	0	0	0

iv. Register 07h : Output High-Impedance

The Output High-Impedance Register determines whether pins set as output are enabled or high-impedance

- When a bit in this register is set to 0, the corresponding GPIO-port output state follows register the output port register (05h).
- When a bit in this register is set to 1, the corresponding GPIO-port output is set to high-impedance.
- Bit values in this register have no effect on pins defined as inputs. In turn, reads from this register reflect the value that is in the flip-flop controlling the output selection, not the actual pin value.

Table 10: Output High-Impedance Register (address 07h)

Bit	B7	B6	B5	B4	B3	B2	B1	B0
Name	P7	P6	P5	P4	P3	P2	P1	P0
Default	1	1	1	1	1	1	1	1

v. Register 09h : Input Default State

The Input Default State Register sets the default state of the GPIO-port input for generating interrupts.

- When a bit in this register is set to 0, the default for the corresponding input is set to LOW
- When a bit in this register is set to 1, the default for the corresponding input is set to HIGH
- Bit values in this register have no effect on pins defined as outputs. In turn, reads from this register reflect the value that is in the flip-flop controlling the default state, not the actual pin value.

Table 11. Input Default State Register (address 09h)

Bit	B7	B6	B5	B4	B3	B2	B1	B0
Name	P7	P6	P5	P4	P3	P2	P1	P0
Default	0	0	0	0	0	0	0	0

vi. Register 0bh : Pull-Up/-Down Enable

The Pull-up/-down Enable Register enables or disables the pull-up/down resistor on the GPIO-port as defined in the Pull-up/-down Select Register (0Dh).

- When a bit in this register is set to 0, the pull-up/down on the corresponding GPIO is disabled.
- When a bit in this register is set to 1, the pull-up/down on the corresponding GPIO is enabled.

Table 12. Pull-up/-down Enable Register (address 0Bh)

Bit	B7	B6	B5	B4	B3	B2	B1	B0
Name	P7	P6	P5	P4	P3	P2	P1	P0
Default	1	1	1	1	1	1	1	1

vii. Register 0Dh : Pull-Up/-Down Select

The Pull-up/down Select Register allows the user to select either a pull-up or pull-down on the GPIO-port. This register only selects the pull-up/down resistor on the GPIO-port, while the enabling/disabling is controlled by the Pull-up/down Enable Register (0Bh).

- When a bit in this register is set to 0, the pull-down on the corresponding GPIO is selected.
- When a bit in this register is set to 1, the pull-up on the corresponding GPIO is selected.

Table 13. Pull-up/-down Select Register (address 0Dh)

Bit	B7	B6	B5	B4	B3	B2	B1	B0
Name	P7	P6	P5	P4	P3	P2	P1	P0
Default	0	0	0	0	0	0	0	0

viii. Register 0Fh : Input Status Register

The Input Status Register reflects the incoming logic levels of the GPIOs set as inputs.

- The default value, X, is determined by the externally applied logic level.
- It only acts on read operation. Attempted writes to this register have no effect.
- For GPIOs set as outputs this register will read LOW.

Table 14. Input Status Register (address 0Fh)

Bit	B7	B6	B5	B4	B3	B2	B1	B0
Name	P7	P6	P5	P4	P3	P2	P1	P0
Default	X	X	X	X	X	X	X	X

ix. Register 11h – Interrupt Mask Register

The Interrupt Mask Register controls the generation of an interrupt to the $\overline{\text{INT}}$ pin when the GPIO-port input state changes state.

- When a bit in this register is set to 0, an interrupt generated by the interrupt status register causes the $\overline{\text{INT}}$ pin to be asserted LOW.
- When a bit in this register is set to 1, the interrupt for the corresponding GPIO is disabled. The corresponding bit in the Interrupt Status Register (13h) will still be asserted.
- $\overline{\text{INT}}$ is not affected when GPIO-port is defined as outputs.

Table 15. Interrupt Mask Register (address 11h)

Bit	B7	B6	B5	B4	B3	B2	B1	B0
Name	P7	P6	P5	P4	P3	P2	P1	P0
Default	0	0	0	0	0	0	0	0

x. Register 13h – Interrupt Status Register

The Interrupt Status Register bit is asserted when the bit changes to a value opposite to the default value defined in the Input Default State Register (09h).

- This bit is cleared and the $\overline{\text{INT}}$ pin is de-asserted upon read of this register.
- The input must be asserted back to the default state before this bit is set again.
- If the GPIO-port pin is defined as an output, this bit is never set.

Table 16. Interrupt Status Register (address 13h)

Bit	B7	B6	B5	B4	B3	B2	B1	B0
Name	P7	P6	P5	P4	P3	P2	P1	P0
Default	X	X	X	X	X	X	X	X

d. I/O Port

When an I/O is configured as an input, the pull-up FET (Q1) and pull-down FET (Q2) are off, which creates a high-impedance input. If the I/O is configured as an output, Q1 or Q2 is enabled depending on the state of the Output Port Register. In this case, there are low impedance paths between the I/O pin and either $V_{DD(P)}$ or GND. The external voltage applied to this I/O pin should not exceed the recommended levels for proper operation. A pull-down FET series with pull-down resistor (Q3) is turned on at power-on to enable the pull-down resistor. Q3 and a pull-up FET series with pull-up resistor (Q4) are enabled accordingly to the Pull-up or Pull-down Select Register and the Pull-up or Pull-down Enable Register.

When the GPIO-port is set as an output the input buffers are disabled such that the bus is allowed to float.

e. Power-on Reset

When power is applied to $V_{DD(I2C_bus)}$, an internal power-on reset holds the PI4IOE5V6408 in a reset condition until $V_{DD(I2C_bus)}$ has reached V_{POR} . At that point, the reset condition is released and the PI4IOE5V6408 registers will initialize to their default states.

f. Reset Input ($\overline{\text{RESET}}$)

The $\overline{\text{RESET}}$ input can be asserted to initialize the system while keeping $V_{\text{DD(P)}}$ at its operating level. A reset can be accomplished by holding the $\overline{\text{RESET}}$ pin low for a minimum of t_w . The PI4IOE5V6408 registers are changed to their default state once $\overline{\text{RESET}}$ is low (0). Only when $\overline{\text{RESET}}$ is high (1), GPIO registers can be accessed by the I²C pin. This input requires a pull-up resistor to $V_{\text{DD(I2C_bus)}}$, if no active connection is used.

g. Software Reset

The PI4IOE5V6408 can be reset by the processor using an I²C write command to change bit 0 of register 01h to a 1. Immediately following this change, the PI4IOE5V6408 resets and all register values return to their default values. In this case, the software reset bit returns to 0 as soon as the reset sequence is completed.

h. Interrupt output ($\overline{\text{INT}}$)

The $\overline{\text{INT}}$ pin is a LOW-asserted open-drain output and requires an external pull-up resistor. The PI4IOE5V6408 signals an interrupt to the processor when an event occurs, removing the need for the processor to continuously poll the PI4IOE5V6408 registers.

Immediately after detecting a change at an input, the PI4IOE5V6408 writes the corresponding bit in the input interrupt status register (13h) and asserts the $\overline{\text{INT}}$ pin by pulling it LOW. The interrupt status register bit remains HIGH until the processor reads the register and clears the bit. If the input pin remains in the non-default state after the interrupt has been serviced, a new interrupt is not generated until after the input state has first returned to its default state and changed back to its non-default state. The PI4IOE5V6408 also contains an Input Status register (0Fh) used to verify the current status of the given input at the time when the interrupt is serviced by the processor. These two registers allow the processor to determine the following information about any input every time the register map is read:

- If the input state changed from the default state since the most recent register read; and
- The current state of the input pin.

The interrupt output $\overline{\text{INT}}$, once asserted, is held LOW until the interrupt is serviced by the processor. This means that the system uses level-sensitive interrupts. Interrupt signaling is asynchronous to the SCL signal.

I²C Read /Write Procedures

Figure 6 and Figure 7 illustrate compatible I²C write and read sequences. The PI4IOE5V6408 does not support burst read modes described in the I²C standard.

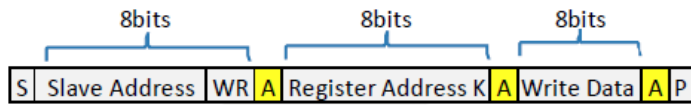
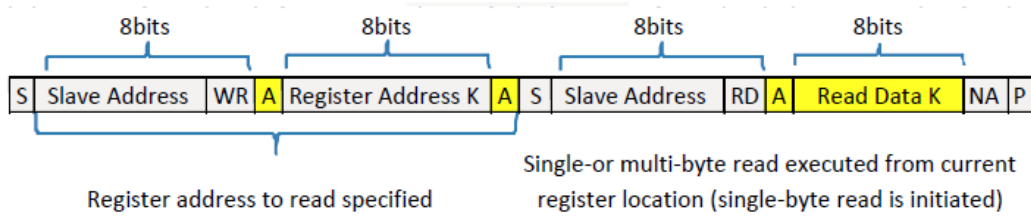

Fig 6. I²C Write Sequence



Note : if register is not specified , the master reads from the current register

Fig 7. I²C Read Sequence

	From Master to Slave	S	Start Condition	NA	NOT Acknowledge (SDA High)
	From Slave to Master	A	Acknowledge (SDA Low)	WR	Write=0

Application Design-In Information

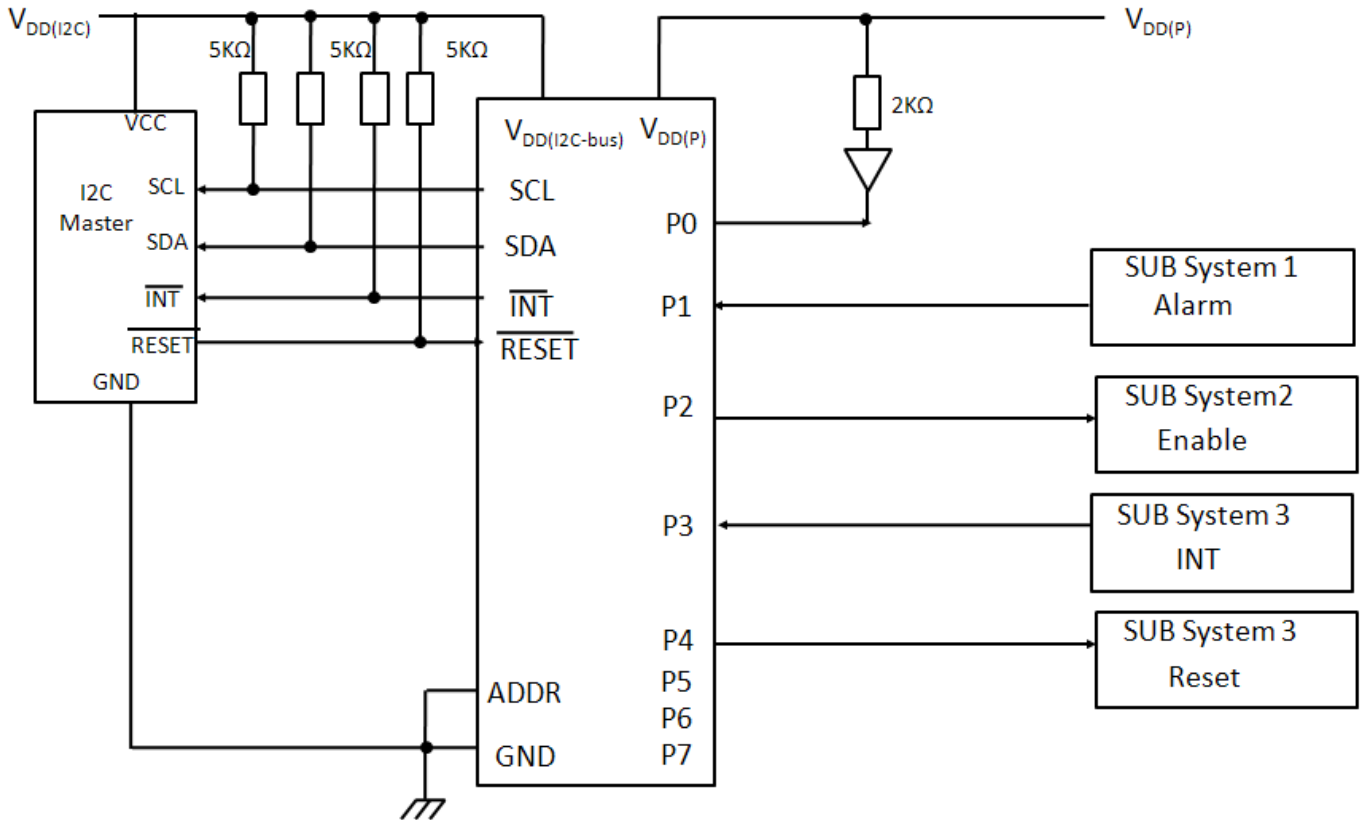

Fig 8. Typical Application

The SCL and SDA pins must be tied directly to $V_{DD(I2C-bus)}$ because if SCL and SDA are tied to an auxiliary power supply that could be powered on while $V_{DD(I2C-bus)}$ is powered off, then the supply current, I_{CC} , will increase as a result.

- A. Device address is configured as 86(h) or 87(h) for this example (depending on R/W bit).
- B. P0,P2,P4 are configured as outputs.
- C. P1,P3 are configured as inputs.
- D. P5,P6,P7 are not used.

Part Marking

ZTA Packaging



Y: Year

W: Workweek

Packaging Mechanical
16-UQFN (ZTA)

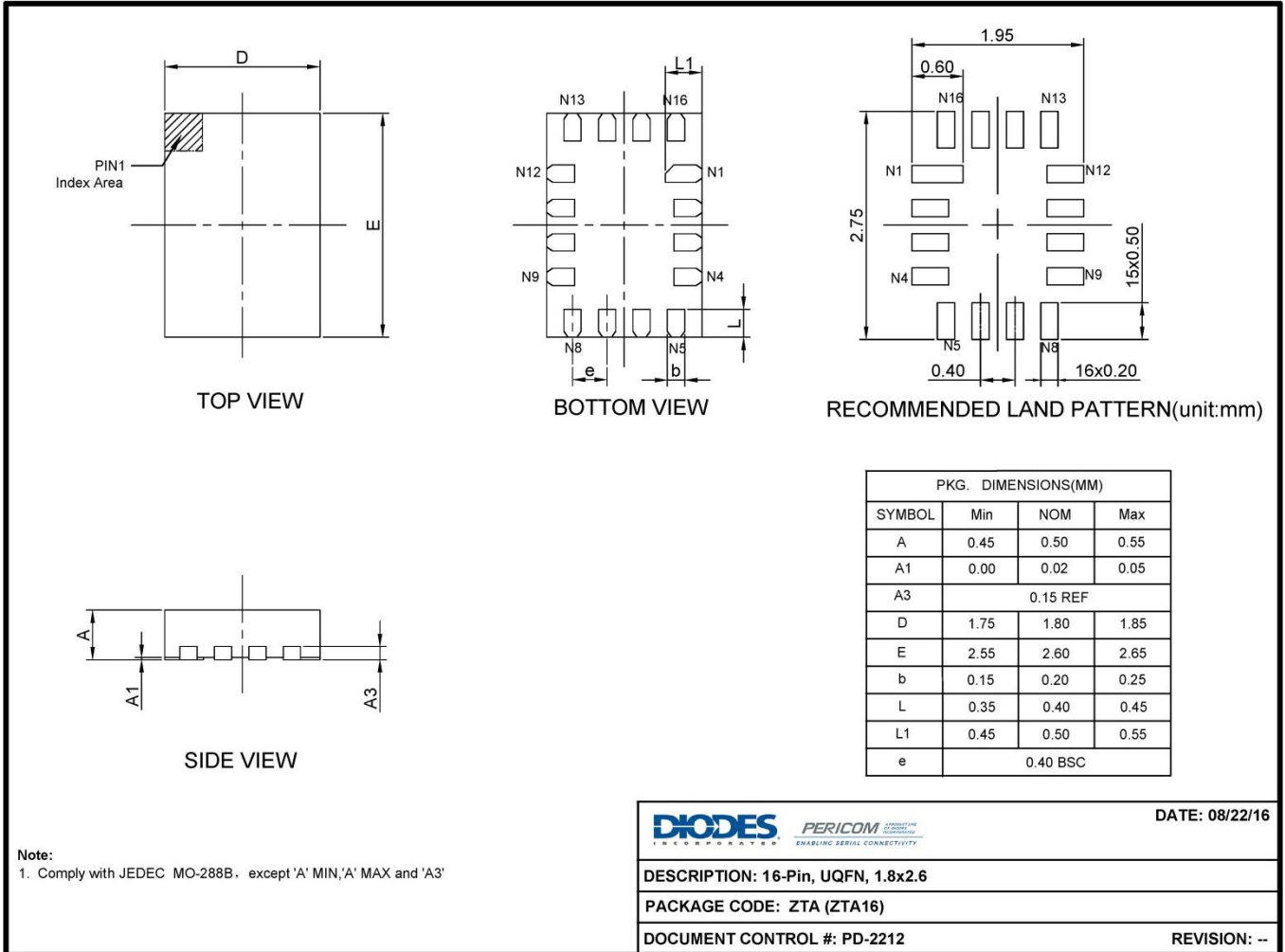

16-0164

For latest package info.

please check: <http://www.diodes.com/design/support/packaging/pericom-packaging/packaging-mechanicals-and-thermal-characteristics/>

Ordering Information

Part No.	Package Code	Package
PI4IOE5V6408ZTAEX	ZTA	16-Pin, 1.8x2.6 (UQFN)

- Notes:**
- EU Directive 2002/95/EC (RoHS), 2011/65/EU (RoHS 2) & 2015/863/EU (RoHS 3). Compliant. All applicable RoHS exemptions applied.
 - See <http://www.diodes.com/quality/lead-free/> for more information about Diodes Incorporated's definitions of Halogen- and Antimony-free, "Green" and Lead-free.
 - Thermal characteristics can be found on the company web site at www.diodes.com/design/support/packaging/
 - E = Pb-free and Green
 - X suffix = Tape/Reel

IMPORTANT NOTICE

DIODES INCORPORATED MAKES NO WARRANTY OF ANY KIND, EXPRESS OR IMPLIED, WITH REGARDS TO THIS DOCUMENT, INCLUDING, BUT NOT LIMITED TO, THE IMPLIED WARRANTIES OF MERCHANTABILITY AND FITNESS FOR A PARTICULAR PURPOSE (AND THEIR EQUIVALENTS UNDER THE LAWS OF ANY JURISDICTION).

Diodes Incorporated and its subsidiaries reserve the right to make modifications, enhancements, improvements, corrections or other changes without further notice to this document and any product described herein. Diodes Incorporated does not assume any liability arising out of the application or use of this document or any product described herein; neither does Diodes Incorporated convey any license under its patent or trademark rights, nor the rights of others. Any Customer or user of this document or products described herein in such applications shall assume all risks of such use and will agree to hold Diodes Incorporated and all the companies whose products are represented on Diodes Incorporated website, harmless against all damages.

Diodes Incorporated does not warrant or accept any liability whatsoever in respect of any products purchased through unauthorized sales channel.

Should Customers purchase or use Diodes Incorporated products for any unintended or unauthorized application, Customers shall indemnify and hold Diodes Incorporated and its representatives harmless against all claims, damages, expenses, and attorney fees arising out of, directly or indirectly, any claim of personal injury or death associated with such unintended or unauthorized application.

Products described herein may be covered by one or more United States, international or foreign patents pending. Product names and markings noted herein may also be covered by one or more United States, international or foreign trademarks.

This document is written in English but may be translated into multiple languages for reference. Only the English version of this document is the final and determinative format released by Diodes Incorporated.

LIFE SUPPORT

Diodes Incorporated products are specifically not authorized for use as critical components in life support devices or systems without the express written approval of the Chief Executive Officer of Diodes Incorporated. As used herein:

A. Life support devices or systems are devices or systems which:

1. are intended to implant into the body, or
2. support or sustain life and whose failure to perform when properly used in accordance with instructions for use provided in the labeling can be reasonably expected to result in significant injury to the user.

B. A critical component is any component in a life support device or system whose failure to perform can be reasonably expected to cause the failure of the life support device or to affect its safety or effectiveness.

Customers represent that they have all necessary expertise in the safety and regulatory ramifications of their life support devices or systems, and acknowledge and agree that they are solely responsible for all legal, regulatory and safety-related requirements concerning their products and any use of Diodes Incorporated products in such safety-critical, life support devices or systems, notwithstanding any devices- or systems-related information or support that may be provided by Diodes Incorporated. Further, Customers must fully indemnify Diodes Incorporated and its representatives against any damages arising out of the use of Diodes Incorporated products in such safety-critical, life support devices or systems.

Copyright © 2016, Diodes Incorporated
www.diodes.com