



Chipsmall Limited consists of a professional team with an average of over 10 year of expertise in the distribution of electronic components. Based in Hongkong, we have already established firm and mutual-benefit business relationships with customers from,Europe,America and south Asia,supplying obsolete and hard-to-find components to meet their specific needs.

With the principle of “Quality Parts,Customers Priority,Honest Operation,and Considerate Service”,our business mainly focus on the distribution of electronic components. Line cards we deal with include Microchip,ALPS,ROHM,Xilinx,Pulse,ON,Everlight and Freescale. Main products comprise IC,Modules,Potentiometer,IC Socket,Relay,Connector.Our parts cover such applications as commercial,industrial, and automotives areas.

We are looking forward to setting up business relationship with you and hope to provide you with the best service and solution. Let us make a better world for our industry!



Contact us

Tel: +86-755-8981 8866 Fax: +86-755-8427 6832

Email & Skype: info@chipsmall.com Web: www.chipsmall.com

Address: A1208, Overseas Decoration Building, #122 Zhenhua RD., Futian, Shenzhen, China



4-Bit I2C-Bus and SMBus Low Power I/O Port

Features

- Operation power supply voltage from 2.3V to 5.5V
- 4-bit I²C-bus GPIO with 5V tolerant I/Os
- Polarity inversion register
- Low current consumption
- 0Hz to 1MHz clock frequency
- Noise filter on SCL/SDA inputs
- Power-on reset
- 4 I/O pin which default to 4 inputs with 100kΩ pull-up resistor
- ESD protection (4KV HBM and 1KV CDM)
- Offered in three different packages:SOIC-8,MSOP-8 and TDFN2x3-8

Pin Configuration

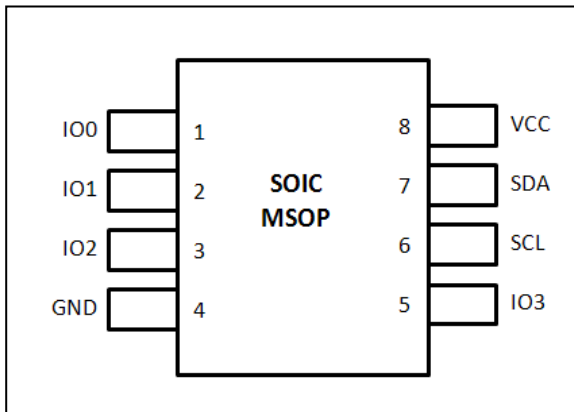

Figure1 : SOIC-8 & MSOP-8

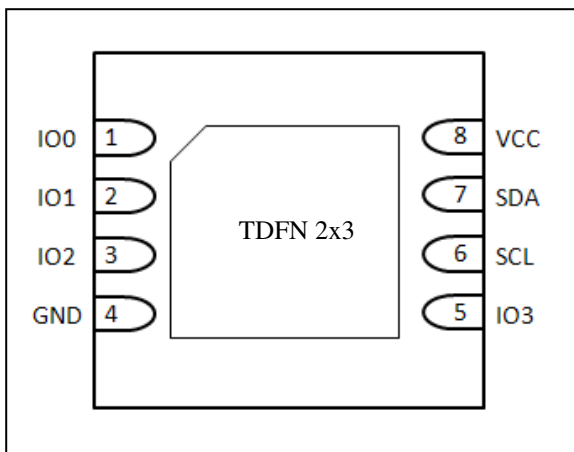

Figure2 : TDFN 2x3-8

Description

The PI4IOE5V9536 provides 4 bits of General Purpose parallel Input/Output (GPIO) expansion for I²C-bus/ SMBus applications. It includes the features such as higher driving capability, 5V tolerance, lower power supply, individual I/O configuration, and smaller packaging. It provides a simple solution when additional I/O is needed for ACPI power switches, sensors, push buttons, LEDs, fans, etc.

The PI4IOE5V9536 consists of a 4-bit registers to configure the I/Os as either inputs or outputs, and a 4-bit polarity registers to change the polarity of the input port register data. The data for each input or output is kept in the corresponding Input port or Output port register. All registers can be read by the system master.

Pin Description

* I = Input; O = Output; P = Power; G = Ground

Pin	Name	Type	Description
1	IO0	I/O	input/output 0
2	IO1	I/O	input/output 1
3	IO2	I/O	input/output 2
4	GND	G	Supply Ground
5	IO3	I/O	input/output 3
6	SCL	I	Serial clock line
7	SDA	I/O	Serial data line
8	VCC	P	Power supply

Maximum Ratings

Power supply.....	-0.5V to +6.0V
Voltage on an I/O pin.....	GND-0.5V to +6.0V
Input current.....	±20mA
Output current on an I/O pin.....	±50mA
Supply current.....	85mA
Ground supply current.....	100mA
Total power dissipation.....	200mW
Operation temperature.....	-40~85°C
Storage temperature.....	-65~150°C
Maximum Junction temperature, T _{j(max)}	125°C

Note:

Stresses greater than those listed under MAXIMUM RATINGS may cause permanent damage to the device. This is a stress rating only and functional operation of the device at these or any other conditions above those indicated in the operational sections of this specification is not implied. Exposure to absolute maximum rating conditions for extended periods may affect reliability.

Static Characteristics

VCC = 2.3 V to 5.5 V; GND = 0 V; Tamb = -40 °C to +85 °C; unless otherwise specified.

Table 2: Static characteristic

Symbol	Parameter	Conditions	Min.	Typ.	Max.	Unit
Power supply						
VCC	Supply voltage		2.3	-	5.5	V
I _{CC}	Supply current	Operating mode; VCC = 5.5 V; no load; f _{SCL} = 1MHz,	-	100	150	μA
		Operating mode; VCC = 2.3V; no load; f _{SCL} = 1MHz		20	40	μA
I _{sb}	Standby current	Standby mode; VCC = 5.5 V; no load; V _I = GND; f _{SCL} = 0 kHz; I/O = inputs	-	225	350	uA
		Standby mode; VCC = 5.5 V; no load; V _I = VCC; f _{SCL} = 0 kHz; I/O = inputs	-	0.25	1	μA
V _{FOR}	Power-on reset voltage ^[1]		-	1.16	1.41	V
Input SCL, input/output SDA						
V _{IL}	Low level input voltage		-0.5	-	+0.3VCC	V
V _{IH}	High level input voltage		0.7VCC	-	5.5	V
I _{OL}	Low level output current	V _{OL} = 0.4V	3	6	-	mA
I _L	Leakage current	V _I = VCC = GND	-1	-	1	μA
C _i	Input capacitance	V _I = GND	-	6	10	pF

Symbol	Parameter	Conditions	Min.	Typ.	Max.	Unit
I/Os						
V _{IL}	Low level input voltage		-0.5	-	+0.81	V
V _{IH}	High level input voltage		+1.8	-	5.5	V
I _{OL}	Low level output current	VCC = 2.3 V; V _{OL} = 0.5 V ^[2]	8	10	-	mA
		VCC = 2.3 V; V _{OL} = 0.7 V ^[2]	10	13	-	mA
		VCC = 3.0 V; V _{OL} = 0.5 V ^[2]	8	14	-	mA
		VCC = 3.0 V; V _{OL} = 0.7 V ^[2]	10	19	-	mA
		VCC = 4.5 V; V _{OL} = 0.5 V ^[2]	8	17	-	mA
		VCC = 4.5 V; V _{OL} = 0.7 V ^[2]	10	24	-	mA
V _{OH}	High level output voltage	I _{OH} = -8mA; VCC = 2.3V ^[3]	1.8	-	-	V
		I _{OH} = -10mA; VCC = 2.3V ^[3]	1.7	-	-	V
		I _{OH} = -8mA; VCC = 3.0V ^[3]	2.6	-	-	V
		I _{OH} = -10mA; VCC = 3.0V ^[3]	2.5	-	-	V
		I _{OH} = -8mA; VCC = 4.75V ^[3]	4.1	-	-	V
		I _{OH} = -10mA; VCC = 4.75V ^[3]	4.0	-	-	V
I _{LIH}	High level input leakage current	VCC = 3.6V; V _I = VCC	-	-	1	μA
I _{LIL}	Low level input leakage current	VCC = 5.5V; V _I = GND	-	-	-100	μA
C _i	Input capacitance		-	3.7	10	pF
C _o	Output capacitance		-	3.7	10	pF

Note:

[1]: VCC must be lowered to 0.2 V for at least 5 us in order to reset part.

[2]: Each I/O must be externally limited to a maximum of 25 mA and the device must be limited to a maximum current of 100 mA

[3]: The total current sourced by all I/Os must be limited to 85mA.

Dynamic Characteristics

Table 3: Dynamic characteristics

Symbol	Parameter	Test Conditions	Standard mode I ² C		Fast mode I ² C		Fast mode Plus I ² C		Unit
			Min	Max	Min	Max	Min	Max	
f _{SCL}	SCL clock frequency		0	100	0	400	0	1000	kHz
t _{BUF}	bus free time between a STOP and START condition		4.7	-	1.3	-	0.5	-	μs
t _{HD;STA}	hold time (repeated) START condition		4.0	-	0.6	-	0.26	-	μs
t _{SU;STA}	set-up time for a repeated START condition		4.7	-	0.6	-	0.26	-	μs
t _{SU;STO}	set-up time for STOP condition		4.0	-	0.6	-	0.26	-	μs
t _{VD;ACK} ^[1]	data valid acknowledge time		-	3.45	-	0.9	-	0.45	μs
t _{HD;DAT} ^[2]	data hold time		0	-	0	-	0	-	ns
t _{VD;DAT}	data valid time		-	3.45	-	0.9	-	0.45	us
t _{SU;DAT}	data set-up time		250	-	100	-	50	-	ns
t _{LOW}	LOW period of the SCL clock		4.7	-	1.3	-	0.5	-	μs
t _{HIGH}	HIGH period of the SCL clock		4.0	-	0.6	-	0.26	-	μs
t _f	fall time of both SDA and SCL signals		-	300	-	300	-	120	ns
t _r	rise time of both SDA and SCL signals		-	1000	-	300	-	120	ns
t _{SP}	pulse width of spikes that must be suppressed by the input filter		-	50	-	50	-	50	ns
Port timing									
t _{v(Q)}	Data output valid time ^[3]		-	200	-	200	-	200	ns
t _{su(D)}	Data input set-up time		100	-	100	-	100	-	ns
T _{h(D)}	Data input hold time		1	-	1	-	1	-	μs

Note:

 [1]: t_{VD;ACK} = time for acknowledgement signal from SCL LOW to SDA (out) LOW.

 [2]: t_{VD;DAT} = minimum time for SDA data out to be valid following SCL LOW.

 [3]: t_{v(Q)} measured from 0.7VCC on SCL to 50% I/O output.

PI4IOE5V9536 Block Diagram

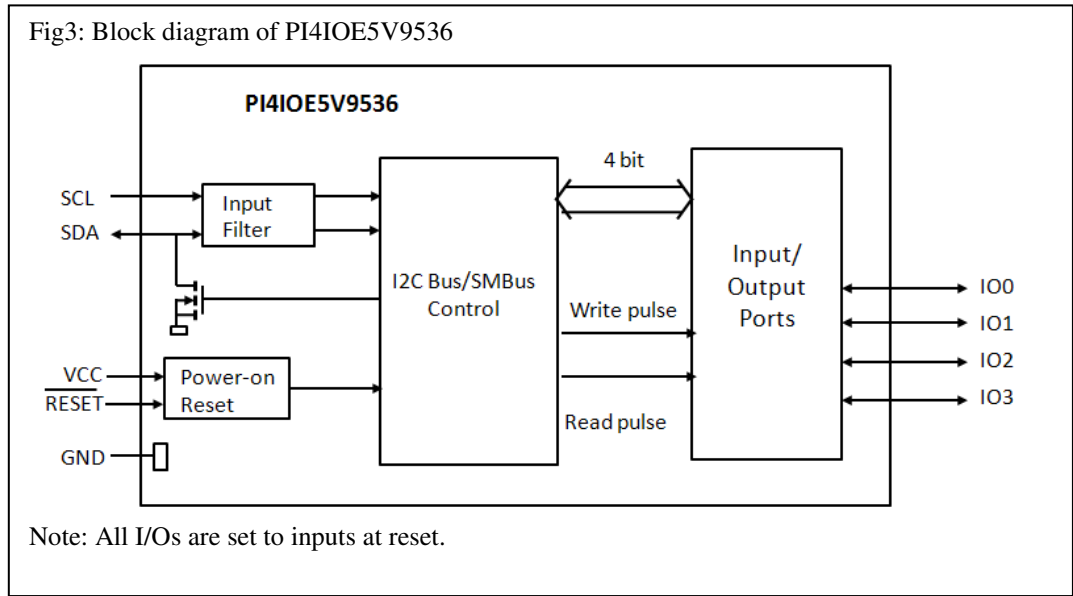

Details Description

a. Device address

Table 4: Device address

	b7(MSB)	b6	b5	b4	b3	b2	b1	b0
Address Byte	1	0	0	0	0	0	1	R/W

Note: Read “1”, Write “0”

b. Registers

i. Command byte

The command byte is the first byte to follow the address byte during a write transmission. It is used as a pointer to determine which of the following registers will be written or read.

Table 5: Command byte

Command	Register
0	Input port register
1	Output port register
2	Polarity inversion register
3	Configuration register

ii. Register 0: input port registers

This register is a read-only port. It reflects the incoming logic levels of the pins, regardless of whether the pin is defined as an input or an output by Register 2. Writes to this register have no effect.

The default value 'X' is determined by the externally applied logic level.

Table 6: Input port 0 register

Bit	7	6	5	4	3	2	1	0
Symbol	I7	I6	I5	I4	I3	I2	I1	I0
Default	1	1	1	1	X	X	X	X

iii. Register 1: Output port register

This register is an output-only port. It reflects the outgoing logic levels of the pins defined as outputs by Registers 3. Bit values in this register have no effect on pins defined as inputs. In turn, reads from this register reflect the value that is in the flip-flop controlling the output selection, not the actual pin value.

Table 8: Output port 0 register

Bit	7	6	5	4	3	2	1	0
Symbol	O7	O6	O5	O4	O3	O2	O1	O0
Default	1	1	1	1	1	1	1	1

iv. Register 2: Polarity inversion register

This register allows the user to invert the polarity of the Input port register data. If a bit in this register is set (written with '1'), the Input port data polarity is inverted. If a bit in this register is cleared (written with a '0'), the Input port data polarity is retained.

Table 10: Polarity Inversion port 0 register

Bit	7	6	5	4	3	2	1	0
Symbol	N7	N6	N5	N4	N3	N2	N1	N0
Default	0	0	0	0	0	0	0	0

v. Register 3: Configuration registers

This register configures the directions of the I/O pins. If a bit in this register is set (written with '1'), the corresponding port pin is enabled as an input with high-impedance output driver. If a bit in this register is cleared (written with '0'), the corresponding port pin is enabled as an output. At reset, the I/Os are configured as inputs with a weak pull-up to VCC

Table 12: Configuration port 0 register

Bit	7	6	5	4	3	2	1	0
Symbol	C7	C6	C5	C4	C3	C2	C1	C0
Default	1	1	1	1	1	1	1	1

c. Power-on reset

When power is applied to VCC, an internal power-on reset holds the PI4IOE5V9536 in a reset condition until VCC has reached V_{POR} . At that point, the reset condition is released and the PI4IOE5V9536 registers and SMBus state machine will initialize to their default states. Thereafter, VCC must be lowered below 0.2 V to reset the device. For a power reset cycle, VCC must be lowered below 0.2 V and then restored to the operating voltage.

d. I/O port

When an I/O is configured as an input, FETs Q1 and Q2 are off, creating a high-impedance input. The input voltage may be raised above VCC to a maximum of 5.5 V.

If the I/O is configured as an output, then either Q1 or Q2 is on, depending on the state of the Output Port register. Care should be exercised if an external voltage is applied to an I/O configured as an output because of the low-impedance path that exists between the pin and either VCC or GND.

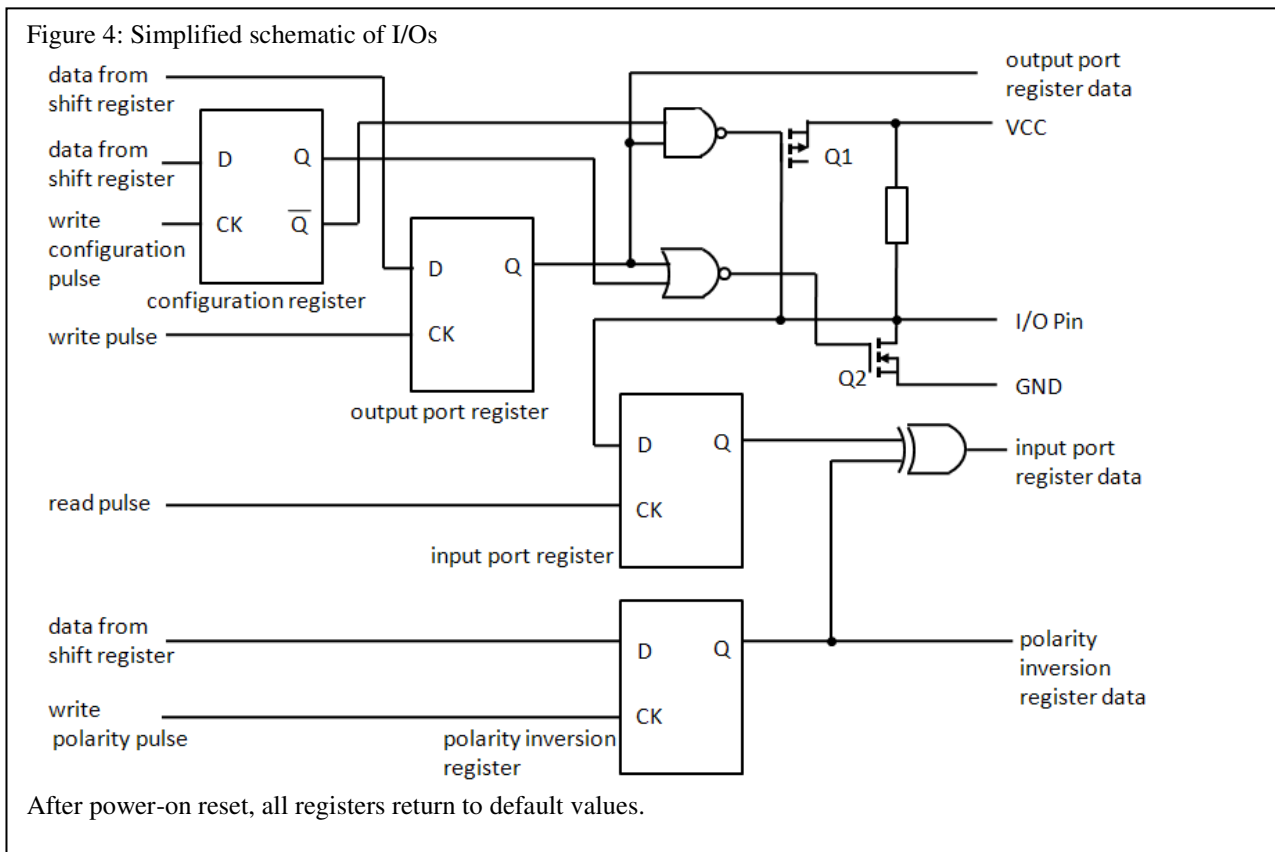

e. Bus Transaction

Data is transmitted to the PI4IOE5V9536 using the Write mode as shown in Figure 5. Data is read from the PI4IOE5V9536 using the read mode as shown in Figure 7. These devices do not implement an auto-increment function, so once a command byte has been sent, the register which was addressed will continue to be accessed by reads until a new command byte has been sent.

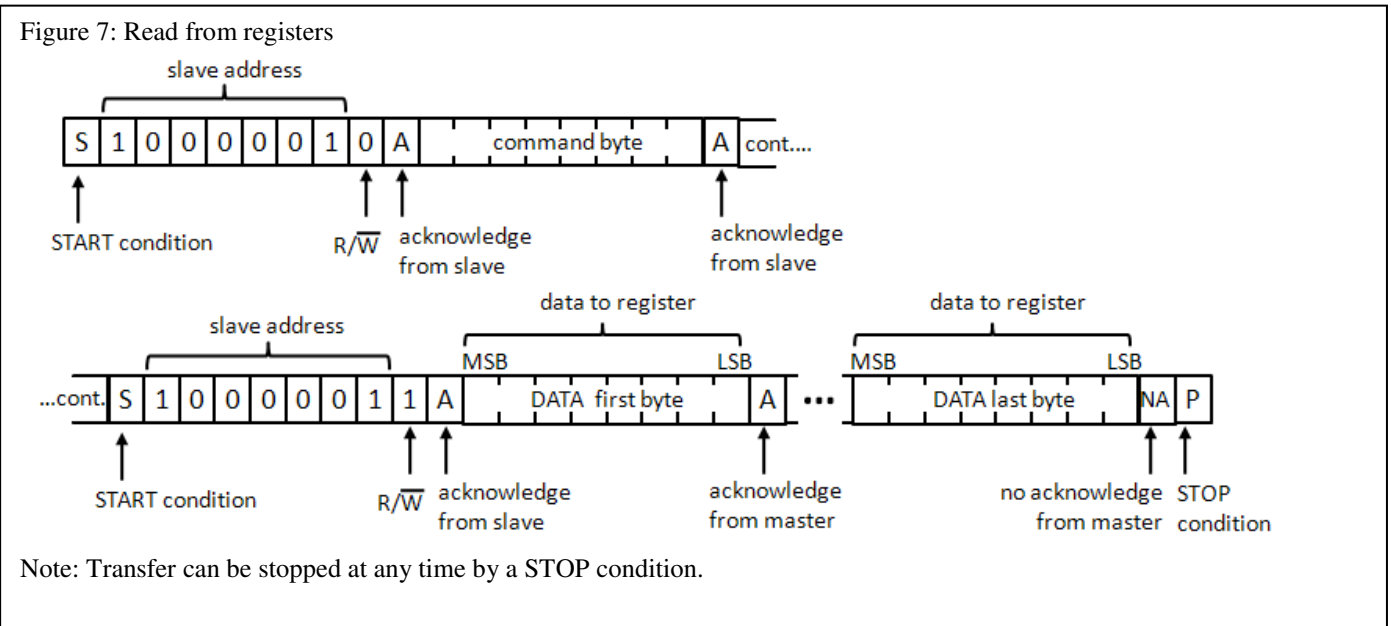
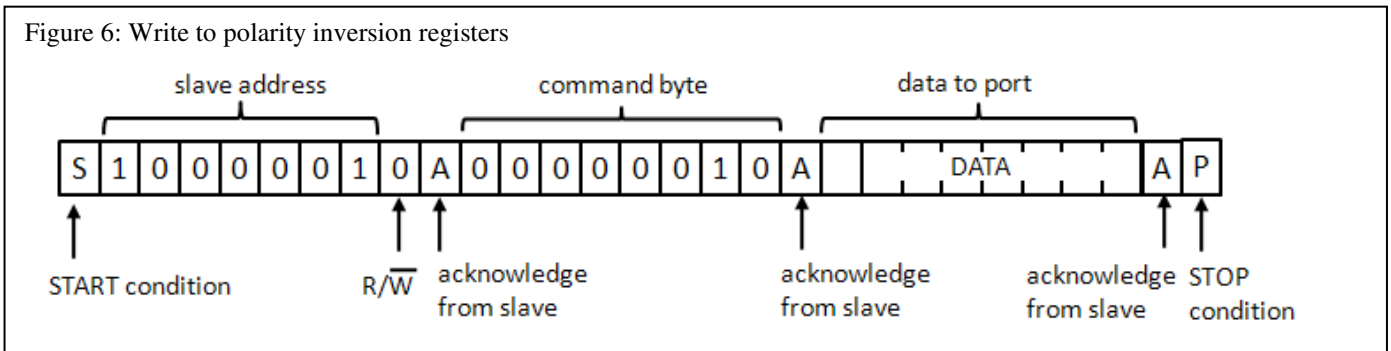
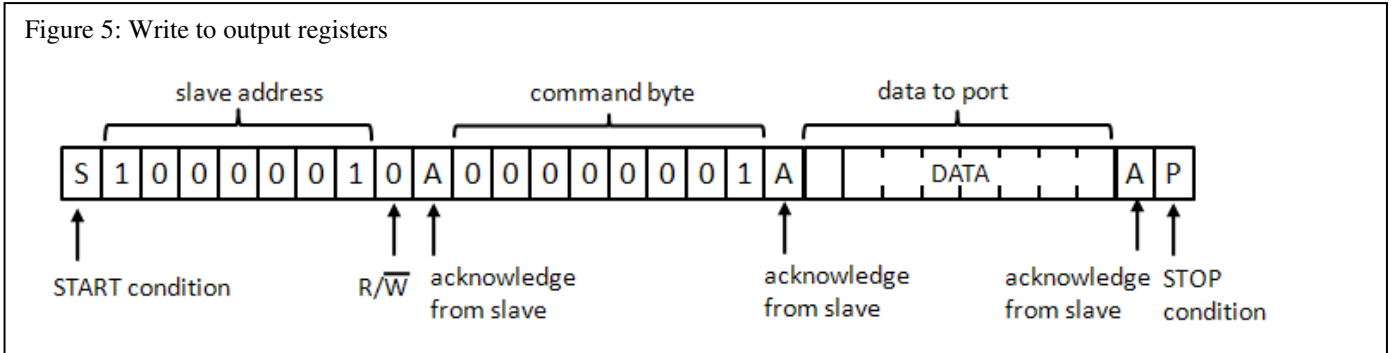
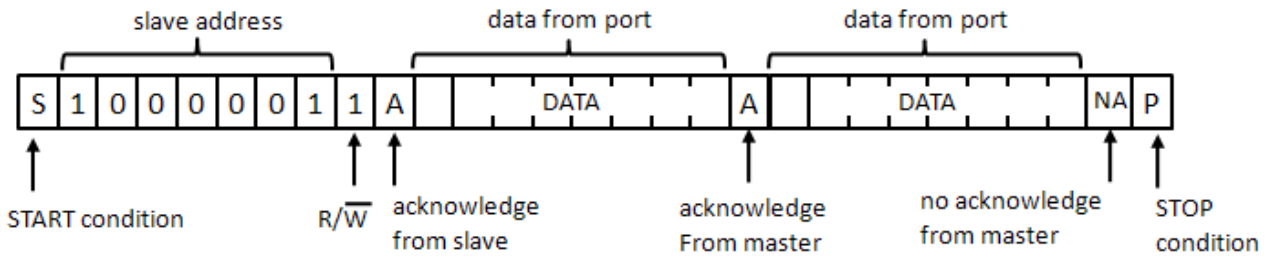

Figure 8: Read Input port register



Note: Transfer of data can be stopped at any moment by a STOP condition. It is assumed that the command byte has previously been set to '00' (read Input Port register).

Application Design-In Information

Figure 9: Typical application

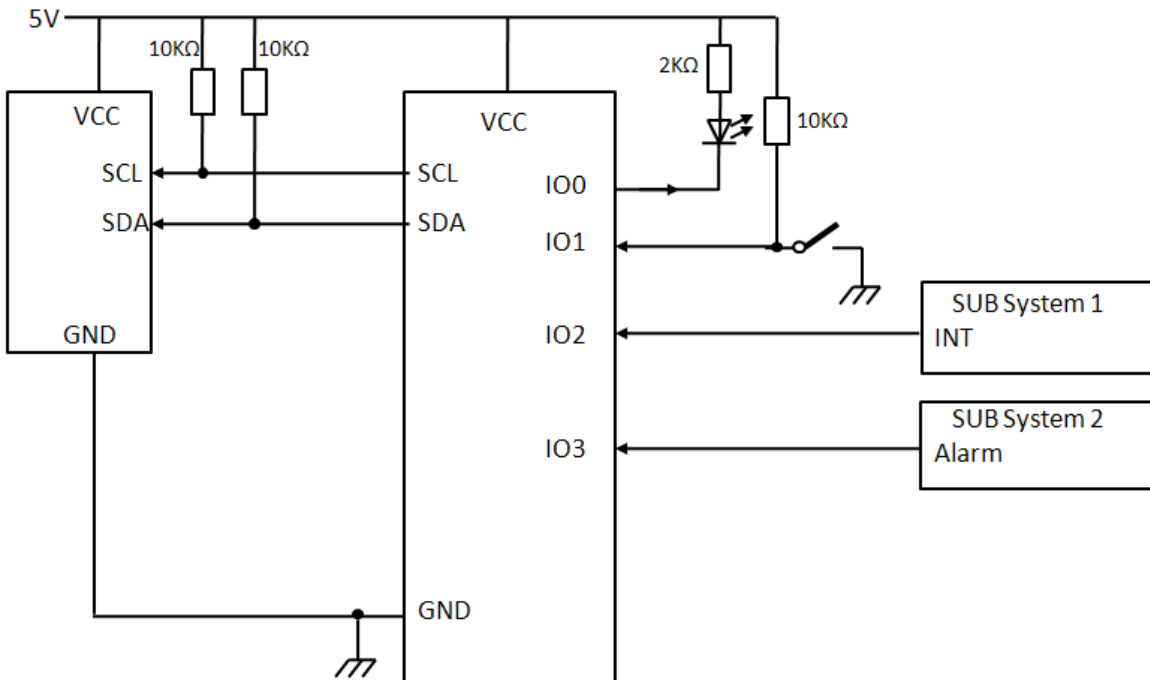

IO0 configured as outputs.
IO1, IO2, IO3 configured as inputs.

Part Marking

U Package

IOE5V9
536UE
ABK \bar{G}

AB: Date Code (Year & Workweek)

K: Assembly Site Code

G: Wafer Fab Site Code

Bar above "G" means Cu wire

W Package and ZE Package

Top mark not available at this time. To obtain advance information regarding the top mark, please contact your local sales representative.

PI4IOE5V9536

Packaging Mechanical
SOIC-8 (W)

SYMBOLS	MIN.	NOM.	MAX.
A	—	—	1.75
A1	0.10	—	0.25
A2	1.25	—	—
b	0.31	—	0.51
c	0.10	—	0.25
D	4.80	4.90	5.00
E	5.80	6.00	6.20
E1	3.80	3.90	4.00
e	1.27 BSC		
L	0.40	—	1.27
h	0.25	—	0.50
θ°	0	—	8

UNIT : mm

NOTE :
 1. ALL DIMENSIONS ARE IN mm. ANGLES IN DEGREES
 2. DIMENSIONS EXCLUDE BURRS, MOLD FLASH OR PROTRUSIONS
 3. REFER JEDEC MS-012

PERICOM Enabling Serial Connectivity	DATE: 02/21/14
DESCRIPTION: 8-Pin, 150mil-Wide, SOIC	
PACKAGE CODE: W (W8)	
DOCUMENT CONTROL #: PD-1001	REVISION: G

15-0103

PI4IOE5V9536

MSOP-8 (U)

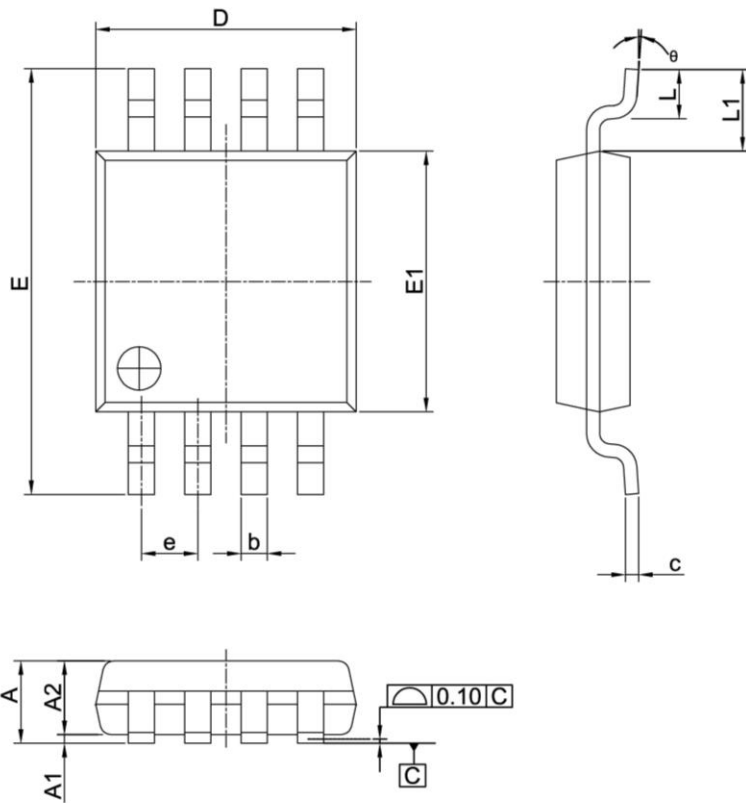

PKG DIMENSIONS(MM)		
SYMBOL	Min.	Max.
A	--	1.10
A1	0.00	0.15
A2	0.75	0.95
b	0.22	0.38
c	0.08	0.23
D	2.80	3.20
E	4.65	5.15
E1	2.80	3.20
e	0.65 BSC	
L	0.40	0.80
L1	0.95 REF	
theta	0°	8°

- NOTE:**
 1. ALL DIMENSIONS ARE IN MILLIMETERS. ANGLES IN DEGREES.
 2. REFER JEDEC MO-187F/AA
 3. PACKAGE OUTLINE DIMENSIONS DO NOT INCLUDE MOLD FLASH AND METAL BURR.

DIODES INCORPORATED	PERICOM A PRODUCT LINE OF DIODES INCORPORATED ENABLING SERIAL CONNECTIVITY	DATE: 11/03/16
DESCRIPTION: 8-Pin, Mini Small Outline Package, MSOP		
PACKAGE CODE: U (U8)		
DOCUMENT CONTROL #: PD-1261	REVISION: G	

16-0242

TDFN-8 (ZE)

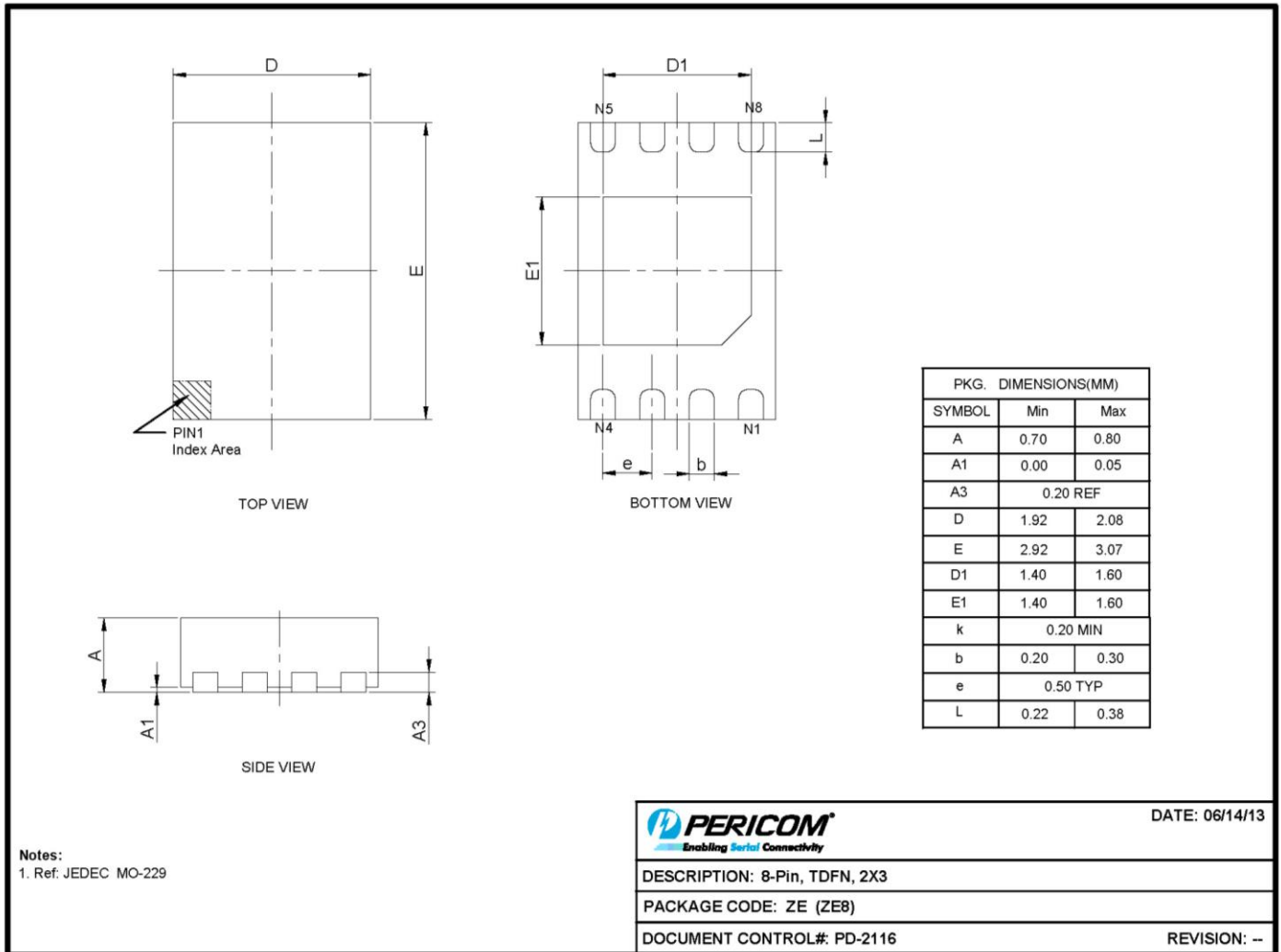

13-0155

For latest package info.

please check: <http://www.diodes.com/design/support/packaging/pericom-packaging/packaging-mechanicals-and-thermal-characteristics/>

Ordering Information

Part Number	Package Code	Package Description
PI4IOE5V9536WEX	W	8-Pin, 150mil-Wide (SOIC)
PI4IOE5V9536UEX	U	8-Pin, Mini Small Outline Package (MSOP)
PI4IOE5V9536ZEEX	ZE	8-Pin, 2x3 (TDFN)

Notes:

- No purposely added lead. Fully EU Directive 2002/95/EC (RoHS), 2011/65/EU (RoHS 2) & 2015/863/EU (RoHS 3).compliant.
- See <http://www.diodes.com/quality/lead-free/> for more information about Diodes Incorporated's definitions of Halogen- and Antimony-free, "Green" and Lead-free.
- Thermal characteristics can be found on the company web site at www.diodes.com/design/support/packaging/
- E = Pb-free and Green
- X suffix = Tape/Reel

IMPORTANT NOTICE

DIODES INCORPORATED MAKES NO WARRANTY OF ANY KIND, EXPRESS OR IMPLIED, WITH REGARDS TO THIS DOCUMENT, INCLUDING, BUT NOT LIMITED TO, THE IMPLIED WARRANTIES OF MERCHANTABILITY AND FITNESS FOR A PARTICULAR PURPOSE (AND THEIR EQUIVALENTS UNDER THE LAWS OF ANY JURISDICTION).

Diodes Incorporated and its subsidiaries reserve the right to make modifications, enhancements, improvements, corrections or other changes without further notice to this document and any product described herein. Diodes Incorporated does not assume any liability arising out of the application or use of this document or any product described herein; neither does Diodes Incorporated convey any license under its patent or trademark rights, nor the rights of others. Any Customer or user of this document or products described herein in such applications shall assume all risks of such use and will agree to hold Diodes Incorporated and all the companies whose products are represented on Diodes Incorporated website, harmless against all damages.

Diodes Incorporated does not warrant or accept any liability whatsoever in respect of any products purchased through unauthorized sales channel.

Should Customers purchase or use Diodes Incorporated products for any unintended or unauthorized application, Customers shall indemnify and hold Diodes Incorporated and its representatives harmless against all claims, damages, expenses, and attorney fees arising out of, directly or indirectly, any claim of personal injury or death associated with such unintended or unauthorized application.

Products described herein may be covered by one or more United States, international or foreign patents pending. Product names and markings noted herein may also be covered by one or more United States, international or foreign trademarks.

This document is written in English but may be translated into multiple languages for reference. Only the English version of this document is the final and determinative format released by Diodes Incorporated.

LIFE SUPPORT

Diodes Incorporated products are specifically not authorized for use as critical components in life support devices or systems without the express written approval of the Chief Executive Officer of Diodes Incorporated. As used herein:

A. Life support devices or systems are devices or systems which:

1. are intended to implant into the body, or
2. support or sustain life and whose failure to perform when properly used in accordance with instructions for use provided in the labeling can be reasonably expected to result in significant injury to the user.

B. A critical component is any component in a life support device or system whose failure to perform can be reasonably expected to cause the failure of the life support device or to affect its safety or effectiveness.

Customers represent that they have all necessary expertise in the safety and regulatory ramifications of their life support devices or systems, and acknowledge and agree that they are solely responsible for all legal, regulatory and safety-related requirements concerning their products and any use of Diodes Incorporated products in such safety-critical, life support devices or systems, notwithstanding any devices- or systems-related information or support that may be provided by Diodes Incorporated. Further, Customers must fully indemnify Diodes Incorporated and its representatives against any damages arising out of the use of Diodes Incorporated products in such safety-critical, life support devices or systems.

Copyright © 2016, Diodes Incorporated
www.diodes.com