



Chipsmall Limited consists of a professional team with an average of over 10 year of expertise in the distribution of electronic components. Based in Hongkong, we have already established firm and mutual-benefit business relationships with customers from,Europe,America and south Asia,supplying obsolete and hard-to-find components to meet their specific needs.

With the principle of “Quality Parts,Customers Priority,Honest Operation,and Considerate Service”,our business mainly focus on the distribution of electronic components. Line cards we deal with include Microchip,ALPS,ROHM,Xilinx,Pulse,ON,Everlight and Freescale. Main products comprise IC,Modules,Potentiometer,IC Socket,Relay,Connector.Our parts cover such applications as commercial,industrial, and automotives areas.

We are looking forward to setting up business relationship with you and hope to provide you with the best service and solution. Let us make a better world for our industry!



Contact us

Tel: +86-755-8981 8866 Fax: +86-755-8427 6832

Email & Skype: info@chipsmall.com Web: www.chipsmall.com

Address: A1208, Overseas Decoration Building, #122 Zhenhua RD., Futian, Shenzhen, China



Low Voltage Dual SPDT 0.8Ω Analog Switch

Features

- CMOS Technology for Bus and Analog Applications
- Low On-Resistance: 0.8Ω at 3.0V
- Wide V_{CC} Range: 1.65V to 5.5V
- Rail-to-Rail Signal Range
- Control Input Overvoltage Tolerance: 5.5V(Min)
- Fast Transition Speed: 12ns at 5.0V
- High Bandwidth: 150 MHz
- Extended Industrial Temperature Range: -40°C to 85°C
- Packaging (Pb-free & Green): 10-Pin MSOP

Applications

- Cell Phones
- PDAs
- Portable Instrumentation
- Battery powered Communications
- Computer Peripherals

Pin Description

Pin No	Name	Description
2, 4	₁ B _x	Data Port (Normally open)
3	GND	Ground
7, 9	₀ B _x	Data Port (Normally closed)
6, 10	A _x	Common Output / Data Port
8	V _{CC}	Positive Power Supply
1, 5	S _x	Logic Control

Logic Function Table

Logic Input (S _x)	Function
0	₀ B _x Connected to A _x
1	₁ B _x Connected to A _x

Note: X= 0 or 1

Description

The PI5A23159 is a dual high-bandwidth, fast single-pole double-throw (SPDT) CMOS switch. It can be used as an analog switch or as a low-delay bus switch. The device features ultra low RON of 0.8Ω typical at 3.0V VCC and will operate over the wide VCC range of 1.65V to 5.5V.

The PI5A23159 features very low quiescent current even when the control voltage is lower than the VCC supply. This feature services the mobile handset applications very well by allowing direct interface with baseband processor general purpose I/Os.

Break-before-make switching prevents both switches being enabled simultaneously. This eliminates signal disruption during switching.

The control input, S, is independent of supply voltage.

Pin Assignment

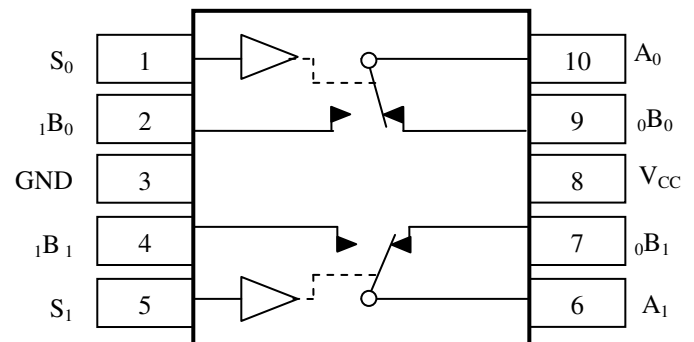

Maximum Ratings

Storage Temperature.....	-65°C to +150°C
Ambient Temperature with Power Applied.....	-40°C to +85°C
Supply Voltage V_{CC}	-0.5V to +7.0V
DC Switch Voltage V_S	-0.5V to +7.0V
DC Input Voltage V_{IN}	-0.5V to +7.0V
DC Output Current V_{OUT}	128mA
DC V_{CC} or Ground Current I_{CC} / I_{GND}	±100mA
Junction Temperature under Bias (T_J)	150°C
Junction Lead Temperature (T_L) (Soldering, 10 seconds)	260°C
ESD (HBM)	5KV
Power Dissipation (PD) @ +85°C	MSOP10 350mW

Note:

Stresses greater than those listed under MAXIMUM RATINGS may cause permanent damage to the device. This is a stress rating only and functional operation of the device at these or any other conditions above those indicated in the operational sections of this specification is not implied. Exposure to absolute maximum rating conditions for extended periods may affect reliability.

Recommended Operating Conditions

Symbol	Parameter	Conditions	Min.	Typ.	Max.	Unit
V_{CC}	Operating Voltage	-	1.65	-	5.5	V
V_{IN}	Control Input Voltage	-	0	-	V_{CC}	V
V_S	Switch Input Voltage	-	0	-	5.5	V
V_{OUT}	Output Voltage	-	0	-	V_{CC}	V
T_A	Operating Temperature	-	-40	25	85	°C
t_r, t_f	Input Rise and Fall Time	Control Input $V_{CC} = 2.7V$ to $3.6V$	0	-	10	ns/V
		Control Input $V_{CC} = 4.5V$ to $5.5V$	0	-	5	ns/V

Note: Control input must be held HIGH or LOW; it must not float.

DC Electrical Characteristics

(T_A = -40°C to 85°C, unless otherwise noted.)

Symbol	Parameter	Test Conditions	Supply Voltage	Min.	Typ.	Max.	Units
V _{IAR}	Analog Input Signal Range	-	V _{CC}	0	-	V _{CC}	V
R _{ON}	ON Resistance ⁽¹⁾	I _{Ax} =100mA, V _{nBx} =0V	V _{CC} =4.5V	-	0.7	1.1	Ω
		I _{Ax} =100mA, V _{nBx} =2.4V		-	0.6	1.0	
		I _{Ax} =100mA, V _{nBx} =4.5V		-	0.8	1.2	
		I _{Ax} =100mA, V _{nBx} =0V	V _{CC} =3.0V	-	0.8	1.3	Ω
		I _{Ax} =100mA, V _{nBx} =3.0V		-	0.9	1.9	
		I _{Ax} =100mA, V _{nBx} =0V	V _{CC} =2.3V	-	1.0	1.5	Ω
		I _{Ax} =100mA, V _{nBx} =2.3V		-	1.2	1.8	
		I _{Ax} =100mA, V _{nBx} =0V	V _{CC} =1.65V	-	1.3	1.9	Ω
I _{Ax} =100mA, V _{nBx} =1.65V	-	2.0		2.8			
ΔR _{ON}	ON Resistance Match Between Channels ^(1,2,3)	I _{Ax} =100mA, V _{nBx} =3.15V	V _{CC} =4.5V	-	0.01	0.12	Ω
		I _{Ax} =100mA, V _{nBx} =2.1V	V _{CC} =3.0V	-	0.02	-	
		I _{Ax} =100mA, V _{nBx} =1.6V	V _{CC} =2.3V	-	0.03	-	
		I _{Ax} =100mA, V _{nBx} =1.15V	V _{CC} =1.65V	-	0.03	-	
R _{ONF}	ON Resistance Flatness ^(1,2,4)	I _{Ax} =100mA, V _{nBx} =0V, 2.4V, 4.5V	V _{CC} =4.5V	-	0.2	0.4	Ω
		I _{Ax} =100mA, V _{nBx} =0V, 1.5V, 3.3V	V _{CC} =3.3V	-	0.2	0.4	
		I _{Ax} =100mA, V _{nBx} =0V, 1.1V, 2.5V	V _{CC} =2.5V	-	0.4	0.6	
		I _{Ax} =100mA, V _{nBx} =0V, 0.7V, 1.8V	V _{CC} =1.8V	-	1.0	1.4	
V _{IH}	Input High Voltage	Logic High Level	V _{CC} =1.65V	0.9	-	-	V
			V _{CC} =2.3V	1.0	-	-	
			V _{CC} =3.0V	1.1	-	-	
			V _{CC} =4.2V	1.2	-	-	
			V _{CC} =5.5V	1.3	-	-	
V _{IL}	Input Low Voltage	Logic Low Level	V _{CC} =1.65V	-	-	0.6	V
			V _{CC} =2.3V	-	-	0.6	
			V _{CC} =3.0V	-	-	0.6	
			V _{CC} =4.2V	-	-	0.8	
			V _{CC} =5.5V	-	-	0.8	
I _{OFF(Bn)}	Source Off Leakage Current	V _{Ax} =1V/4.5V, V _{nBx} =1V/4.5V	V _{CC} =3.0V	-20	-	+20	nA
I _{ON(A, Bn)}	Channel On Leakage Current	-	V _{CC} =1.65V to 5.5V	-40	-	+40	nA
I _{CC}	Quiescent Supply Current	All Channels ON or OFF, V _{nBx} =V _{CC} and GND, I _{OUT} =0A	V _{CC} =3.6V	-	0.002	0.1	μA
			V _{CC} =5.5V	-	0.002	0.1	
I _{CCT}	Increase in I _{CC} per Input	Channel Input at 2.7V	V _{CC} =4.3V	-	0.2	10.0	μA

Notes:

1. Measured by voltage drop between A and B pins at the indicated current through the device. ON resistance is determined by the lower of the voltages on two ports (Ax or nBx) x= 0 or 1, n= 0 or 1.
2. Parameter is characterized but not tested in production.
3. ΔR_{ON} = R_{ON} max – R_{ON} min. measured at identical V_{CC}, temperature and voltage levels.
4. Flatness is defined as difference between maximum and minimum value of ON resistance over the specified range of conditions.

Capacitance⁽¹⁾

Symbol	Parameter	Test Conditions	Supply Voltage	Temp (°C)	Min.	Typ.	Max.	Units
C _{IN}	Control Input	f = 1 MHz	V _{CC} = 5.0V	T _A = 25°C	-	3.5	-	pF
C _{IO-B}	For Bn Port, Switch OFF				-	15.0	-	
C _{IOA-ON}	For An Port, Switch ON				-	34.0	-	

Notes:

1. Capacitance is characterized but not tested in production

Switch and AC Characteristics⁽¹⁾

Parameter	Description	Test Conditions	Supply Voltage	Min	Typ	Max	Units
t_{BBM}	Break Before Make Time	See Figure 2	$V_{\text{CC}} = 2.7\text{V to } 3.6\text{V}$	-	10	-	ns
			$V_{\text{CC}} = 4.5\text{V to } 5.5\text{V}$	-	6	-	
t_{ON}	Turn on Time	See Figure 1	$V_{\text{CC}} = 2.7\text{V to } 3.6\text{V}$	-	16	-	
			$V_{\text{CC}} = 4.5\text{V to } 5.5\text{V}$	-	12	-	
t_{OFF}	Turn off Time	See Figure 1	$V_{\text{CC}} = 2.7\text{V to } 3.6\text{V}$	-	8	-	
			$V_{\text{CC}} = 4.5\text{V to } 5.5\text{V}$	-	5	-	
Q	Charge Injection	$C_{\text{L}} = 1\text{nF}$, $V_{\text{GEN}} = 0\text{V}$, $R_{\text{GEN}} = 0\Omega$. See Figure 3	$V_{\text{CC}} = 5.0\text{V}$	-	35	-	pC
			$V_{\text{CC}} = 3.3\text{V}$	-	25	-	
OIRR	Off Isolation ⁽²⁾	$R_{\text{L}} = 50\Omega$, $V_{\text{GEN}} = 0\text{V}$, $R_{\text{GEN}} = 0\Omega$, $f = 1\text{MHz}$. See Figure 4	$V_{\text{CC}} = 1.65\text{V to } 5.5\text{V}$	-	-70	-	dB
X_{TALK}	Crosstalk Isolation	$f = 1\text{MHz}$, See Figure 5	$V_{\text{CC}} = 1.65\text{V to } 5.5\text{V}$	-	-70	-	
$f_{3\text{dB}}$	-3dB Bandwidth	See Figure 8	$V_{\text{CC}} = 1.65\text{V to } 5.5\text{V}$	-	150	-	MHz
T_{HD}	Total Harmonic Distortion	$R_{\text{L}} = 600\Omega$, $V_{\text{IN}} = 0.5\text{Vpp}$, $f = 20\text{Hz to } 20\text{kHz}$ See Figure 9	$V_{\text{CC}} = 2.7\text{V to } 4.2\text{V}$	-	0.015	-	%

Notes:

1. Guaranteed by design.
2. Off Isolation = $20 \text{ Log}_{10} [V_{\text{nBx}} / V_{\text{Ax}}]$ and is measured in dB.

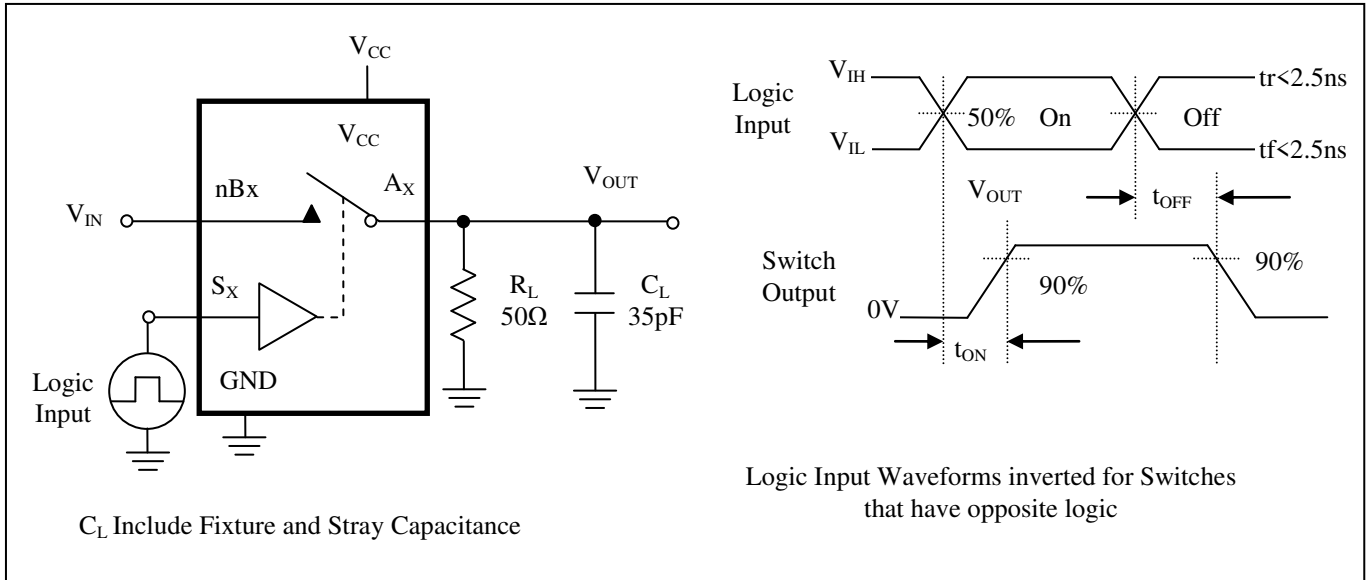
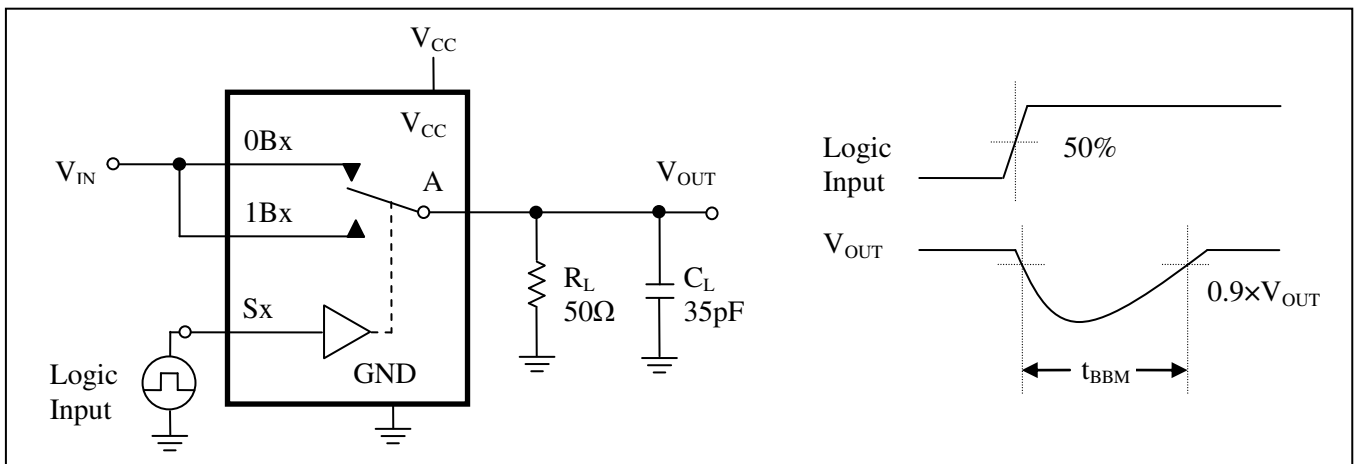
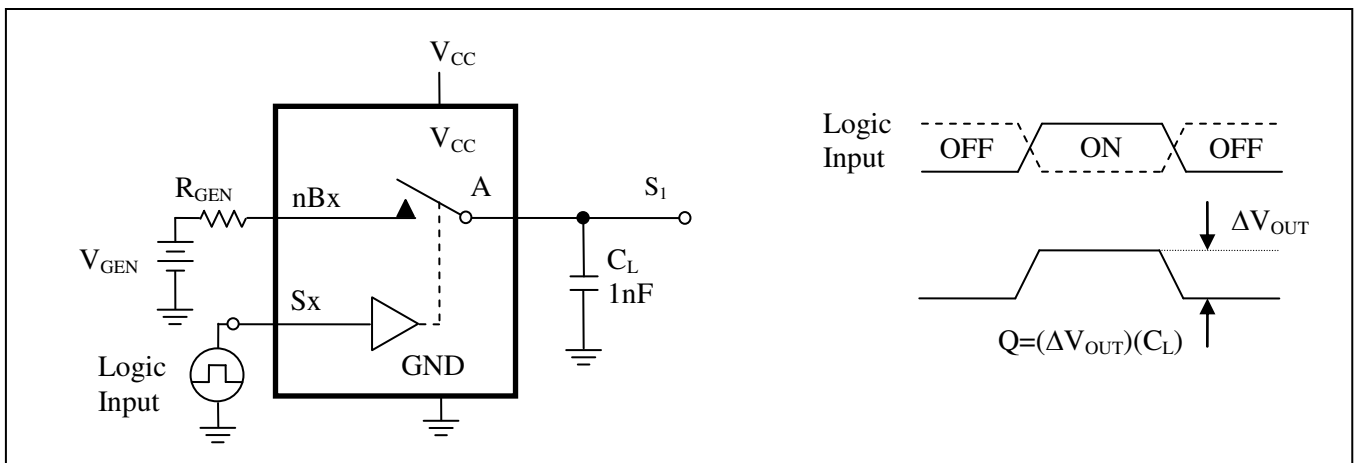
Test Circuits and Timing Diagrams

Figure 1. Turn ON/OFF Timing

Figure 2. Break Before Make Interval Timing

Figure 3. Charge Injection Test

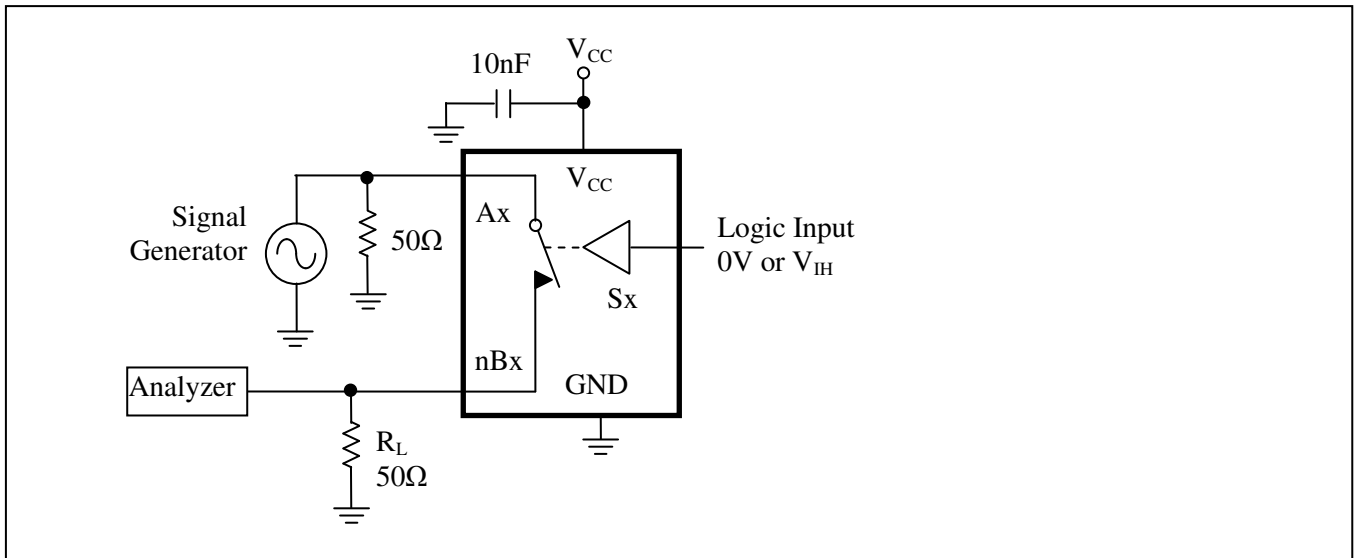

Figure 4. Off Isolation

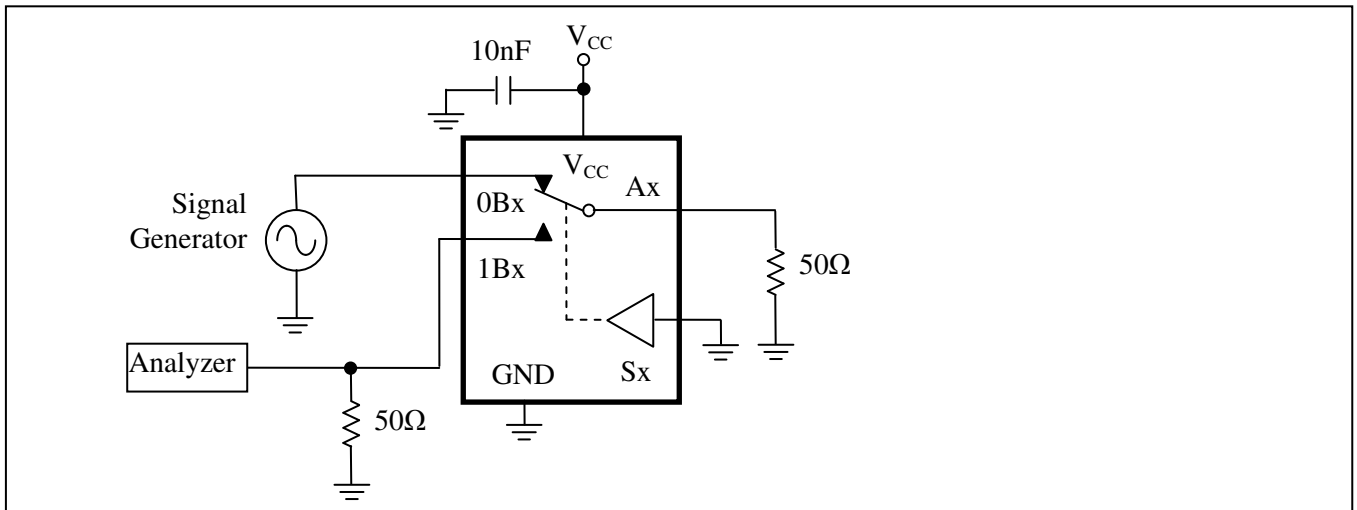

Figure 5. Crosstalk

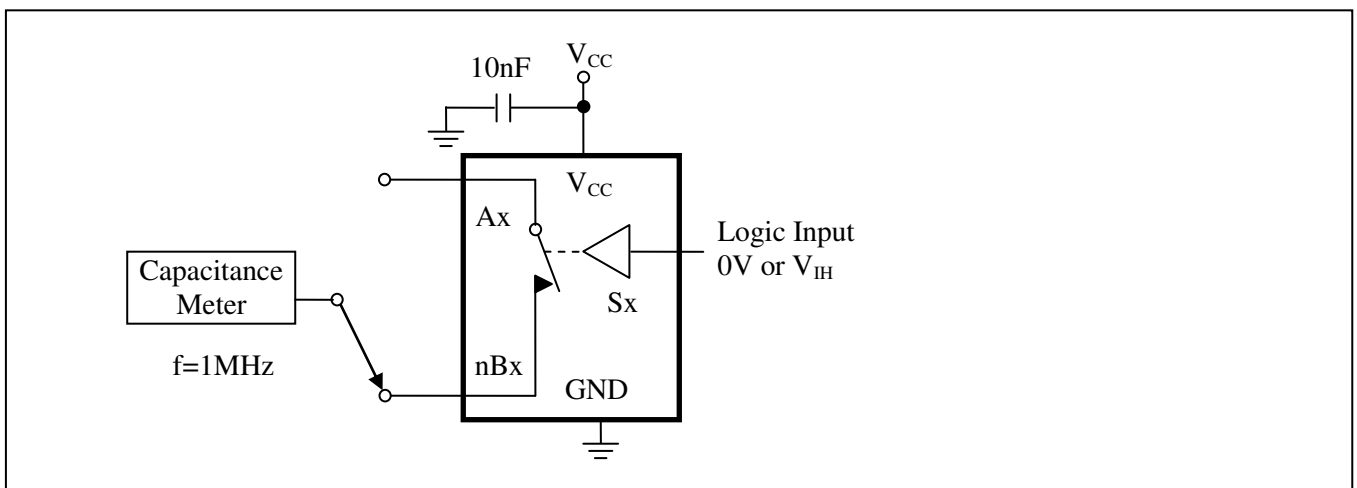

Figure 6. Channel Off Capacitance

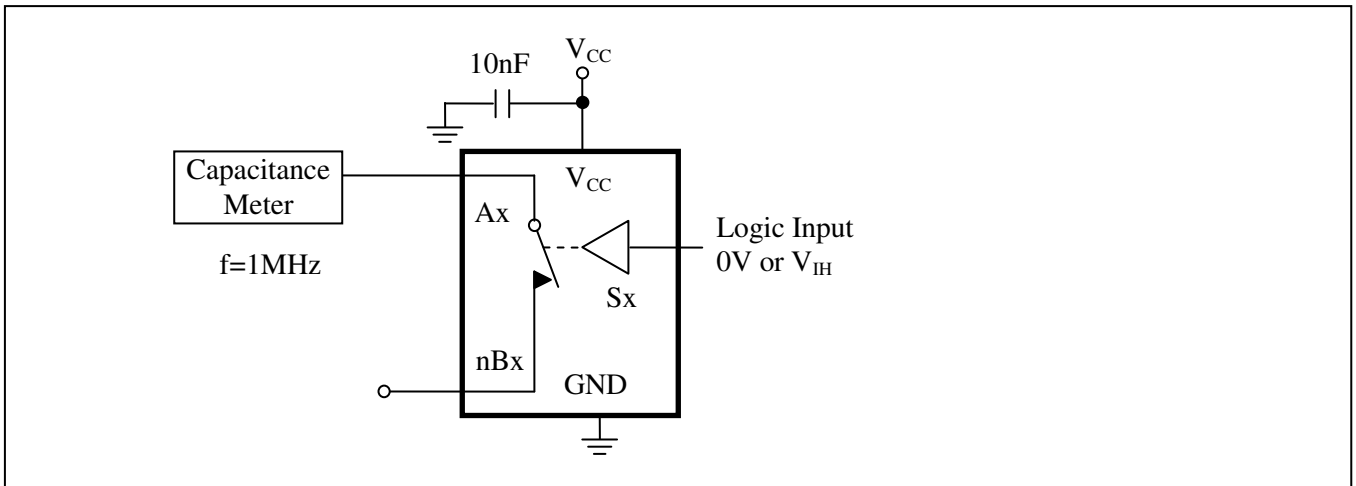

Figure 7. Channel On Capacitance

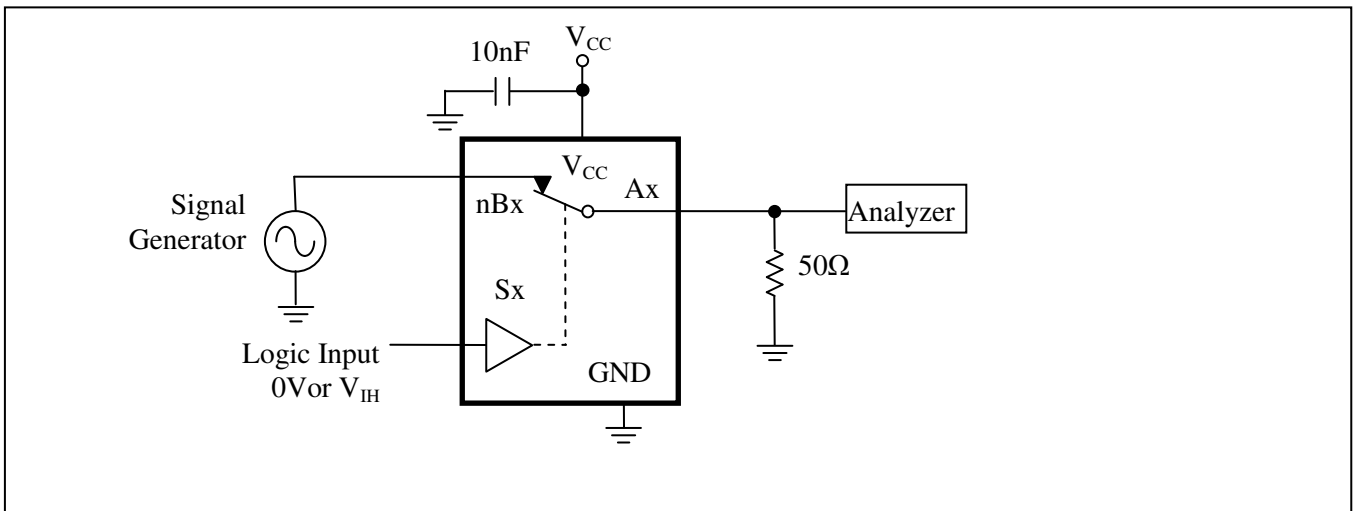

Figure 8. Bandwidth

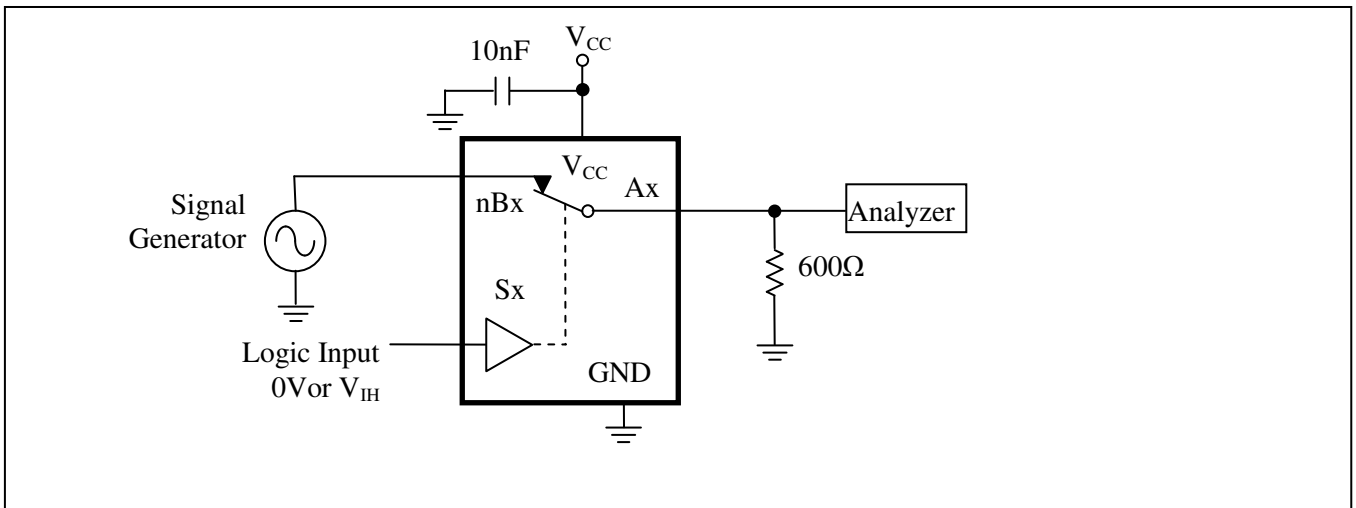
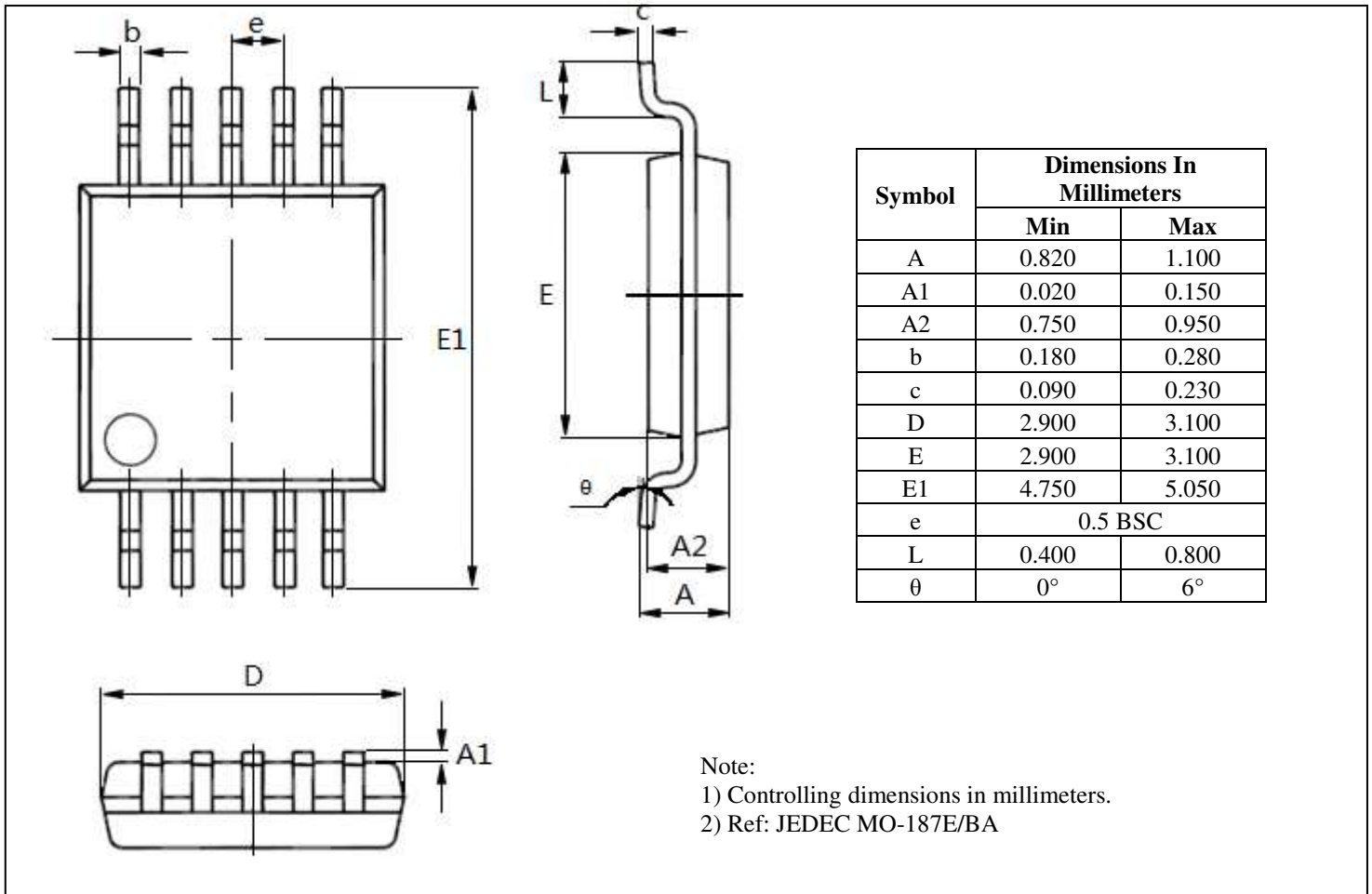

Figure 9. Harmonic Distortion

Mechanical Information
U (10-pin MSOP)

Ordering Information

Part Number	Package Code	Package
PI5A23159UEX	U	Lead Free and Green MSOP-10 (U) Tape & reel

Notes:

- E = Pb-free and Green
- Adding X Suffix= Tape/Reel

 Pericom Semiconductor Corporation • 1-800-435-2336 • www.pericom.com

Pericom reserves the right to make changes to its products or specifications at any time, without notice, in order to improve design or performance and to supply the best possible product. Pericom does not assume any responsibility for use of any circuitry described other than the circuitry embodied in Pericom product. The company makes no representations that circuitry described herein is free from patent infringement or other rights, of Pericom.