



Chipsmall Limited consists of a professional team with an average of over 10 year of expertise in the distribution of electronic components. Based in Hongkong, we have already established firm and mutual-benefit business relationships with customers from,Europe,America and south Asia,supplying obsolete and hard-to-find components to meet their specific needs.

With the principle of “Quality Parts,Customers Priority,Honest Operation,and Considerate Service”,our business mainly focus on the distribution of electronic components. Line cards we deal with include Microchip,ALPS,ROHM,Xilinx,Pulse,ON,Everlight and Freescale. Main products comprise IC,Modules,Potentiometer,IC Socket,Relay,Connector.Our parts cover such applications as commercial,industrial, and automotives areas.

We are looking forward to setting up business relationship with you and hope to provide you with the best service and solution. Let us make a better world for our industry!



Contact us

Tel: +86-755-8981 8866 Fax: +86-755-8427 6832

Email & Skype: info@chipsmall.com Web: www.chipsmall.com

Address: A1208, Overseas Decoration Building, #122 Zhenhua RD., Futian, Shenzhen, China



1:4 Clock Driver for Intel PCIe® 3.0 Chipsets

Features

- Phase jitter filter for PCIe 3.0 application
- Four Pairs of Differential Clocks
- Low skew < 50ps
- Low jitter < 50ps cycle-to-cycle
- < 1 ps additive RMS phase jitter
- Output Enable for all outputs
- Outputs tristate control via SMBus
- Programmable PLL Bandwidth
- 100 MHz PLL Mode operation
- 100 - 400 MHz Bypass Mode operation
- 3.3V Operation
- Packaging (Pb-free and Green):
 - 28-Pin SSOP (H28)
 - 28-Pin TSSOP (L28)

Description

The PI6C20400B is a PCIe 3.0 compliant high-speed, low-noise differential clock buffer designed to be companion to PCIe 3.0 clock generator. It is backward compatible with PCIe 1.0 and 2.0 specification.

The device distributes the differential SRC clock from PCIe 3.0 clock generator to four differential pairs of clock outputs either with or without PLL. The clock outputs are controlled by input selection of SRC_STOP#, PWRDWN# and SMBus, SCLK and SDA. When input of either SRC_STOP# or PWRDWN# is low, the output clocks are Tristated. When PWRDWN# is low, the SDA and SCLK inputs must be Tri-stated.

Block Diagram

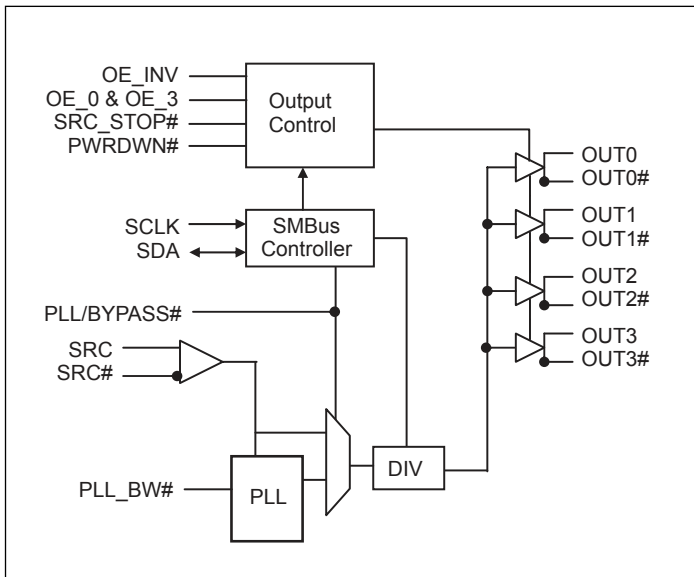

Pin Configuration

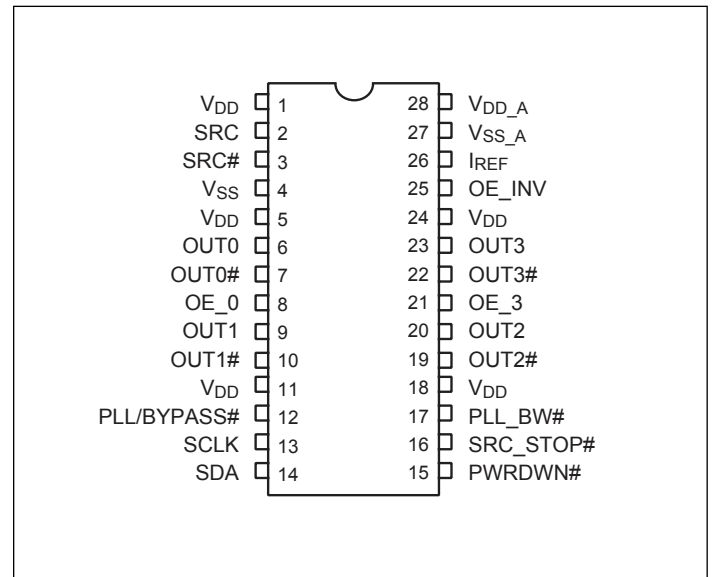

Pinout Table

Pin#	Pin Name	Type	Description
2, 3	SRC & SRC#	Input	0.7V Differential SRC input from PI6C410 clock synthesizer
8, 21	OE_0 & OE_3	Input	3.3V LVTTL input for enabling outputs, active high. OE_0 for OUT0 / OUT0# OE_3 for OUT3 / OUT3#
25	OE_INV	Input	3.3V LVTTL input for inverting the OE, SRC_STOP# and PWRDWN# pins. When 0 = same stage When 1 = OE_0, OE_3, SRC_STOP#, PWRDWN# inverted.
6, 7, 9, 10, 19, 20, 22, 23	OUT[0:3] & OUT[0:3]#	Output	0.7V Differential outputs
12	PLL/BYPASS#	Input	3.3V LVTTL input for selecting fan-out of PLL operation.
13	SCLK	Input	SMBus compatible SCLOCK input
14	SDA	I/O	SMBus compatible SDATA
26	IREF	Input	External resistor connection to set the differential output current
16	SRC_STOP#	Input	3.3V LVTTL input for SRC stop, active low
17	PLL_BW#	Input	3.3V LVTTL input for selecting the PLL bandwidth
15	PWRDWN#	Input	3.3V LVTTL input for Power Down operation, active low
1, 5, 11, 18, 24	V _{DD}	Power	3.3V Power Supply for Outputs
4	VSS	Ground	Ground for Outputs
27	VSS_A	Ground	Ground for PLL
28	VDD_A	Power	3.3V Power Supply for PLL

Serial Data Interface (SMBus)

This part is a slave only SMBus device that supports indexed block read and indexed block write protocol using a single 7-bit address and read/write bit as shown below.

Address Assignment

A6	A5	A4	A3	A2	A1	A0	W/R
1	1	0	1	1	1	0	0/1

Data Protocol

1 bit	7 bits	1	1	8 bits	1	8 bits	1	8 bits	1		8 bits	1	1 bit
Start bit	Slave Addr	R/W	Ack	Register offset	Ack	Byte Count = N	Ack	Data Byte 0	Ack	...	Data Byte N - 1	Ack	Stop bit

Notes:

1. Register offset for indicating the starting register for indexed block write and indexed block read. Byte Count in write mode cannot be 0.

Data Byte 0: Control Register

Bit	Descriptions	Type	Power Up Condition	Output(s) Affected	Source Pin
0	Outputs Mode 0 = Divide by 2 1 = Normal	RW	1 = Normal	OUT[0:3], OUT[0:3]#	NA
1	PLL/BYPASS# 0 = Fanout 1 = PLL	RW	1 = PLL	OUT[0:3], OUT[0:3]#	NA
2	PLL Bandwidth 0 = High Bandwidth, 1 = Low Bandwidth	RW	1 = Low	OUT[0:3], OUT[0:3]#	NA
3	Reserved				NA
4	Reserved				NA
5	Reserved				NA
6	SRC_STOP# 0 = Driven when stopped 1 = Tristate	RW	0 = Driven when stopped	OUT[0:3], OUT[0:3]#	NA
7	PWRDWN# 0 = Driven when stopped 1 = Tristate	RW	0 = Driven when stopped	OUT[0:3], OUT[0:3]#	NA

Data Byte 1: Control Register

Bit	Descriptions	Type	Power Up Condition	Output(s) Affected	Source Pin
0	Reserved				NA
1	OUTPUTS enable	RW	1 = Enabled	OUT0, OUT0#	NA
2	1 = Enabled 0 = Disabled	RW	1 = Enabled	OUT1, OUT1#	NA
3	Reserved				NA
4	Reserved				NA
5	OUTPUTS enable	RW	1 = Enabled	OUT2, OUT2#	NA
6	1 = Enabled 0 = Disabled	RW	1 = Enabled	OUT3, OUT3#	NA
7	Reserved				NA

PI6C20400B

Data Byte 2: Control Register

Bit	Descriptions	Type	Power Up Condition	Output(s) Affected	Source Pin
0	Reserved				NA
1	Allow control of OUTPUTS with assertion of SRC_STOP# 0 = Free running 1 = Stopped with SRC_Stop#	RW	0 = Free running	OUT0, OUT0#	NA
2		RW	0 = Free running	OUT1, OUT1#	NA
3	Reserved				NA
4	Reserved				NA
5	Allow control of OUTPUTS with assertion of SRC_STOP# 0 = Free running 1 = Stopped with SRC_Stop#	RW	0 = Free running	OUT2, OUT2#	NA
6		RW	0 = Free running	OUT3, OUT3#	NA
7	Reserved				NA

Data Byte 3: Control Register

Bit	Descriptions	Type	Power Up Condition	Output(s) Affected	Source Pin
0	Reserved	RW			
1		RW			
2		RW			
3		RW			
4		RW			
5		RW			
6		RW			
7		RW			

Data Byte 3: Control Register

Bit	Descriptions	Type	Power Up Condition	Output(s) Affected	Pin
0	Pericom ID	R	0	NA	NA
1		R	0	NA	NA
2		R	0	NA	NA
3		R	0	NA	NA
4		R	0	NA	NA
5		R	1	NA	NA
6		R	0	NA	NA
7		R	0	NA	NA

Functionality

PWRDWN#	OUT	OUT#	SRC_Stop#	OUT	OUT#
1	Normal	Normal	1	Normal	Normal
0	$I_{REF} \times 2$ or Float	Low	0	$I_{REF} \times 6$ or Float	Low

Power Down (PWRDWN# assertion)

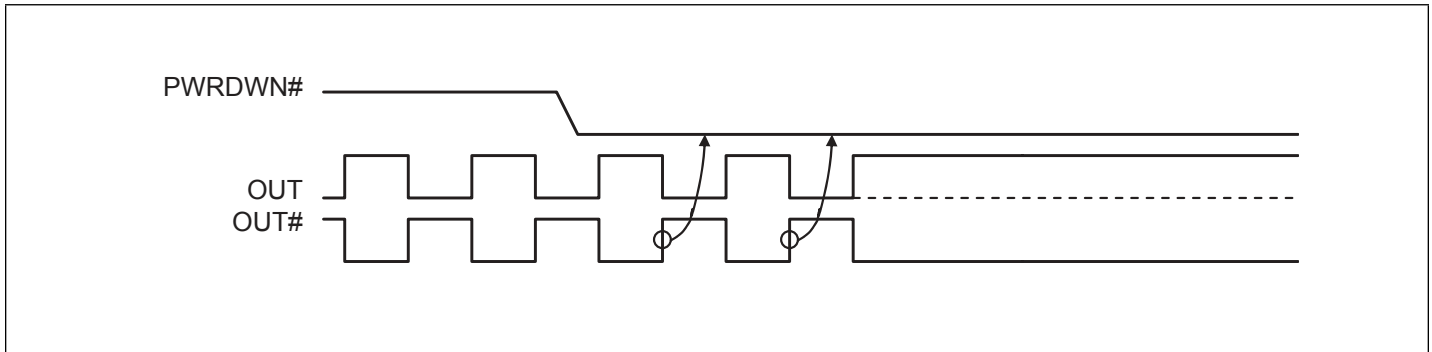

Figure 1. Power down sequence

Power Down (PWRDWN# De-assertion)

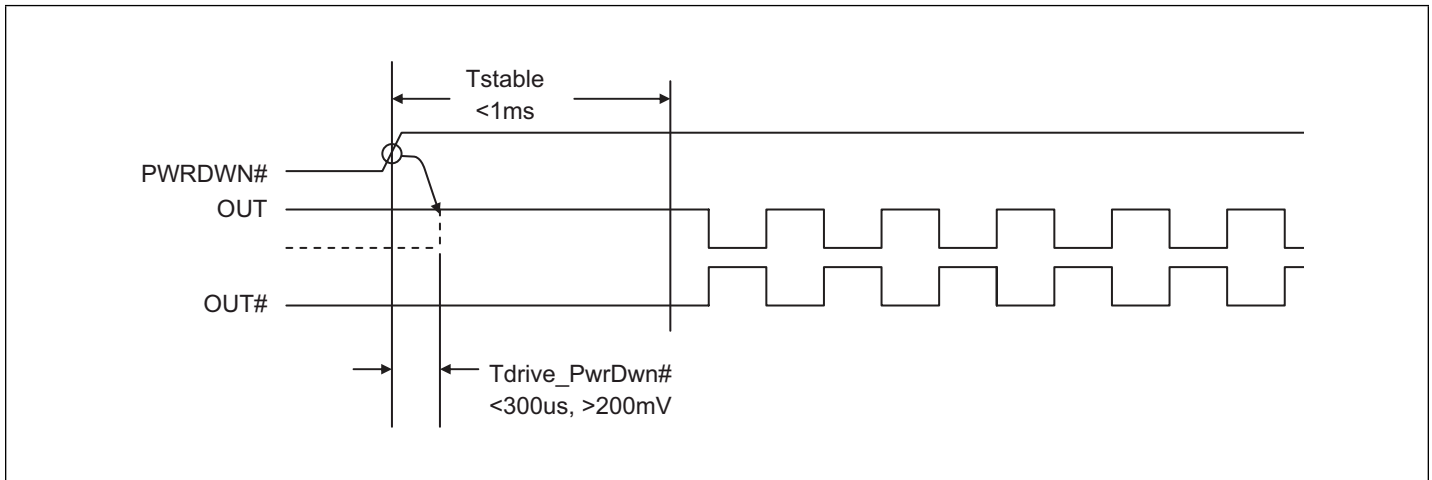
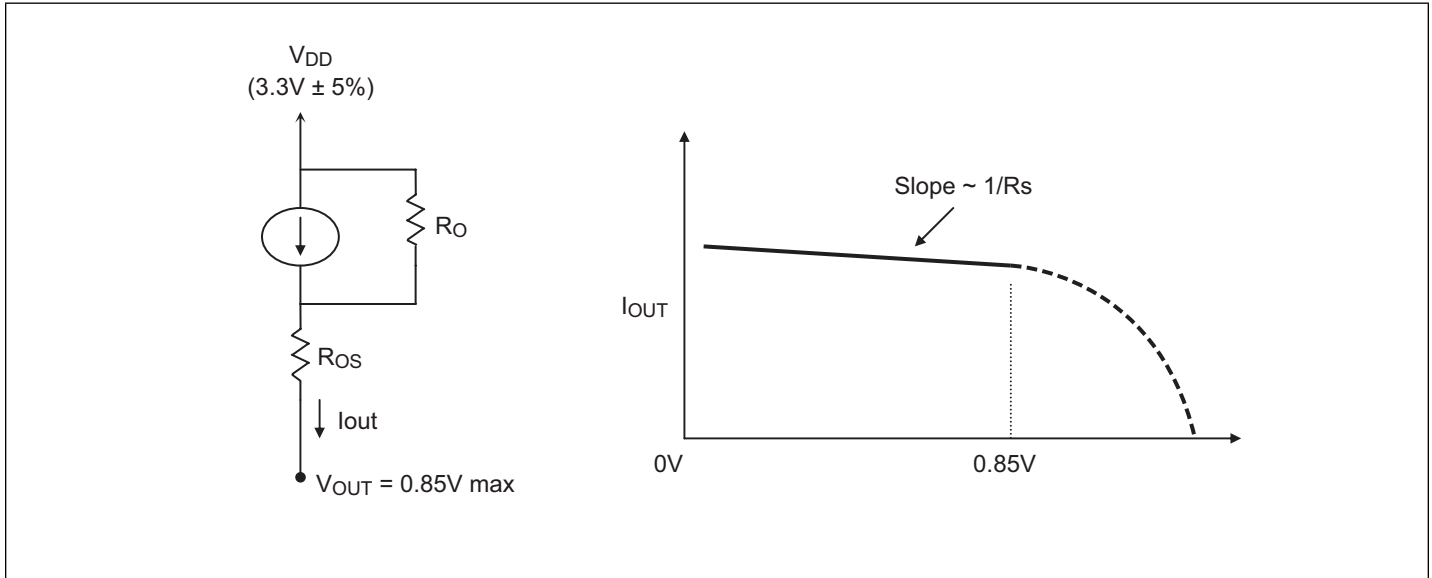

Figure 2. Power down de-assert sequence

Current-mode output buffer characteristics of OUT[0:3], OUT[0:3]#



Differential Clock Buffer characteristics

Symbol	Minimum	Maximum
R_o	3000 Ω	N/A
R_{os}	unspecified	unspecified
V_{OUT}	N/A	850mV

Current Accuracy

Symbol	Conditions	Configuration	Load	Min.	Max.
I_{OUT}	$V_{DD} = 3.30 \pm 5\%$	$R_{REF} = 475\Omega$ 1% $I_{REF} = 2.32mA$	Nominal test load for given configuration	-12% $I_{NOMINAL}$	+12% $I_{NOMINAL}$

Note:

- $I_{NOMINAL}$ refers to the expected current based on the configuration of the device.

Differential Clock Output Current

Board Target Trace/Term Z	Reference R, Iref = $V_{DD}/(3xRr)$	Output Current	V_{OH} @ Z
100 Ω (100 Ω differential \approx 15% coupling ratio)	$R_{REF} = 475\Omega$ 1%, $I_{REF} = 2.32mA$	$I_{OH} = 6 \times I_{REF}$	0.7V @ 50

Absolute Maximum Ratings (Over operating free-air temperature range)

Symbol	Parameters	Min.	Max.	Units
V_{DD_A}	3.3V Core Supply Voltage	-0.5	4.6	V
V_{DD}	3.3V I/O Supply Voltage	-0.5	4.6	
V_{IH}	Input High Voltage		4.6	
V_{IL}	Input Low Voltage	-0.5		
T_s	Storage Temperature	-65	150	°C
V_{ESD}	ESD Protection	2000		V

Note:

1. Stress beyond those listed under “Absolute Maximum Ratings” may cause permanent damage to the device.

DC Electrical Characteristics ($V_{DD} = 3.3 \pm 5\%$, $V_{DD_A} = 3.3 \pm 5\%$)

Symbol	Parameters	Condition	Min.	Max.	Units
V_{DD_A}	3.3V Core Supply Voltage		3.135	3.465	V
V_{DD}	3.3V I/O Supply Voltage		3.135	3.465	
V_{IH}	3.3V Input High Voltage	V_{DD}	2.0	$V_{DD} + 0.3$	
V_{IL}	3.3V Input Low Voltage		$V_{SS} - 0.3$	0.8	
I_{IL}	Input Leakage Current	$0 < V_{IN} < V_{DD}$	-5	+5	μA
V_{OH}	3.3V Output High Voltage	$I_{OH} = -1\text{mA}$	2.4		V
V_{OL}	3.3V Output Low Voltage	$I_{OL} = 1\text{mA}$		0.4	
I_{OH}	Output High Current	$I_{OH} = 6 \times I_{REF}$ $I_{REF} = 2.32\text{mA}$	12.2		mA
				15.6	
C_{IN}	Input Pin Capacitance		3	5	pF
C_{OUT}	Output Pin Capacitance			6	
L_{PIN}	Pin Inductance			7	nH
$I_{DD(BYPASS)}$	Power Supply Current (PLL Bypass)	$V_{DD} = 3.465\text{V}$, $F_{CPU} = 100\text{MHz}$		90	mA
I_{DD}	Power Supply Current	$V_{DD} = 3.465\text{V}$	Bypass mode	100	
		$F_{CPU} = 100\text{MHz}$	PLL mode	130	
I_{SS}	Power Down Current	Driven outputs		40	
I_{SS}	Power Down Current	Tristate outputs		12	
T_A	Ambient Temperature		-40	85	°C

AC Switching Characteristics ($V_{DD} = 3.3 \pm 5\%$, $V_{DD,A} = 3.3 \pm 5\%$)

Symbol	Parameters	Condition	Min.	Typ.	Max.	Units
F_{IN}	PLL Mode		95		105	MHz
	Bypass Mode		100		400	MHz
T_{rise} / T_{fall}^2	Rise and Fall Time (measured between 0.175V to 0.525V)		175		700	ps
DT_{rise} / DT_{fall}^2	Rise and Fall Time Variation				125	ps
T_{pd}	PLL Mode				± 250	ps
	Non-PLL Mode		2.5		6.5	ns
$T_{jitter}^{3,4}$	Cycle – Cycle Jitter				50	ps
V_{HIGH}^2	Voltage High including overshoot		660		1150	mV
V_{LOW}^2	Voltage Low including undershoot		-300			mV
V_{cross}^2	Absolute crossing point voltages		250		550	mV
DV_{cross}^2	Total Variation of Vcross over all edges				140	mV
T_{DC}^3	Duty Cycle		45		55	%
$t_{jphPCIEG1}$	Phase Jitter, PLL Mode	PCIe Gen1		30	86	ps (p-p)
$t_{jphPCIEG2}$		PCIE_2_0_8MHz_1_5M_H3_STEP, Low Freq.	0.7	3	ps (rms)	
		PCIE_2_0_8MHz_1_5M_H3_STEP, High Freq.	2	3.1		
$t_{jphPCIEG3}$		PCIE_3_0_2MHz_5M_H3_FIRST, Low Freq.	2	3		
		PCIE_3_0_2MHz_5M_H3_FIRST, High Freq.	0.47	1		
$t_{jphPCIEG1}$		Additive Phase Jitter, Bypass Mode	PCIe Gen1		0	0.001
$t_{jphPCIEG2}$	PCIE_2_0_8MHz_1_5M_H3_FIRST, Low Freq.			0	0.001	ps (rms)
	PCIE_2_0_8MHz_1_5M_H3_FIRST, High Freq.			0	0.001	
$t_{jphPCIEG3}$	PCIE_3_0_2MHz_5M_H3_FIRST, Low Freq.			0	0.001	
	PCIE_3_0_2MHz_5M_H3_FIRST, High Freq.			0	0.001	

Notes:

1. Test configuration is $R_s = 33.2\Omega$, $R_p = 49.9\Omega$, and 2pF.
2. Measurement taken from Single Ended waveform.
3. Measurement taken from Differential waveform.
4. Measurement taken using M1 data capture analysis tool.
5. Additive jitter is calculated from input and output RMS phase jitter by using PCIe 2.0 filter. ($T_{jadd} = \sqrt{(\text{output jitter})^2 - (\text{input jitter})^2}$)

PI6C20400B

Configuration Test Load Board Termination

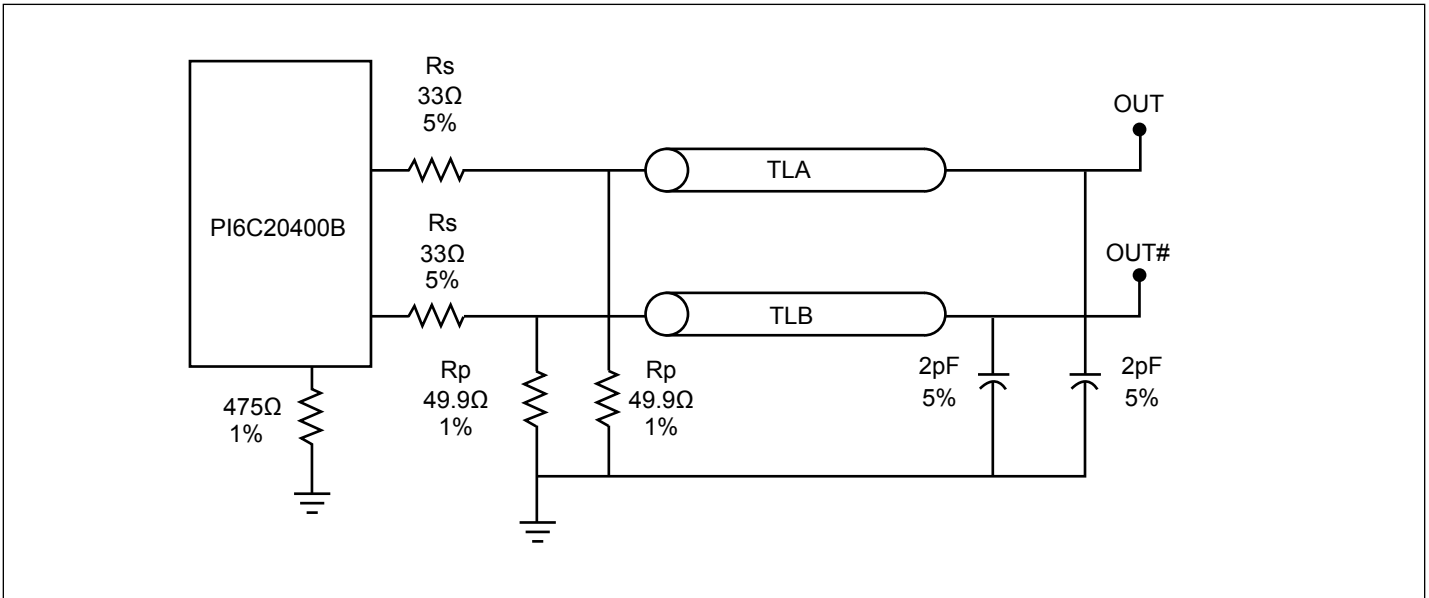

PI6C20400B

Packaging Mechanical: 28-Pin SSOP (H)

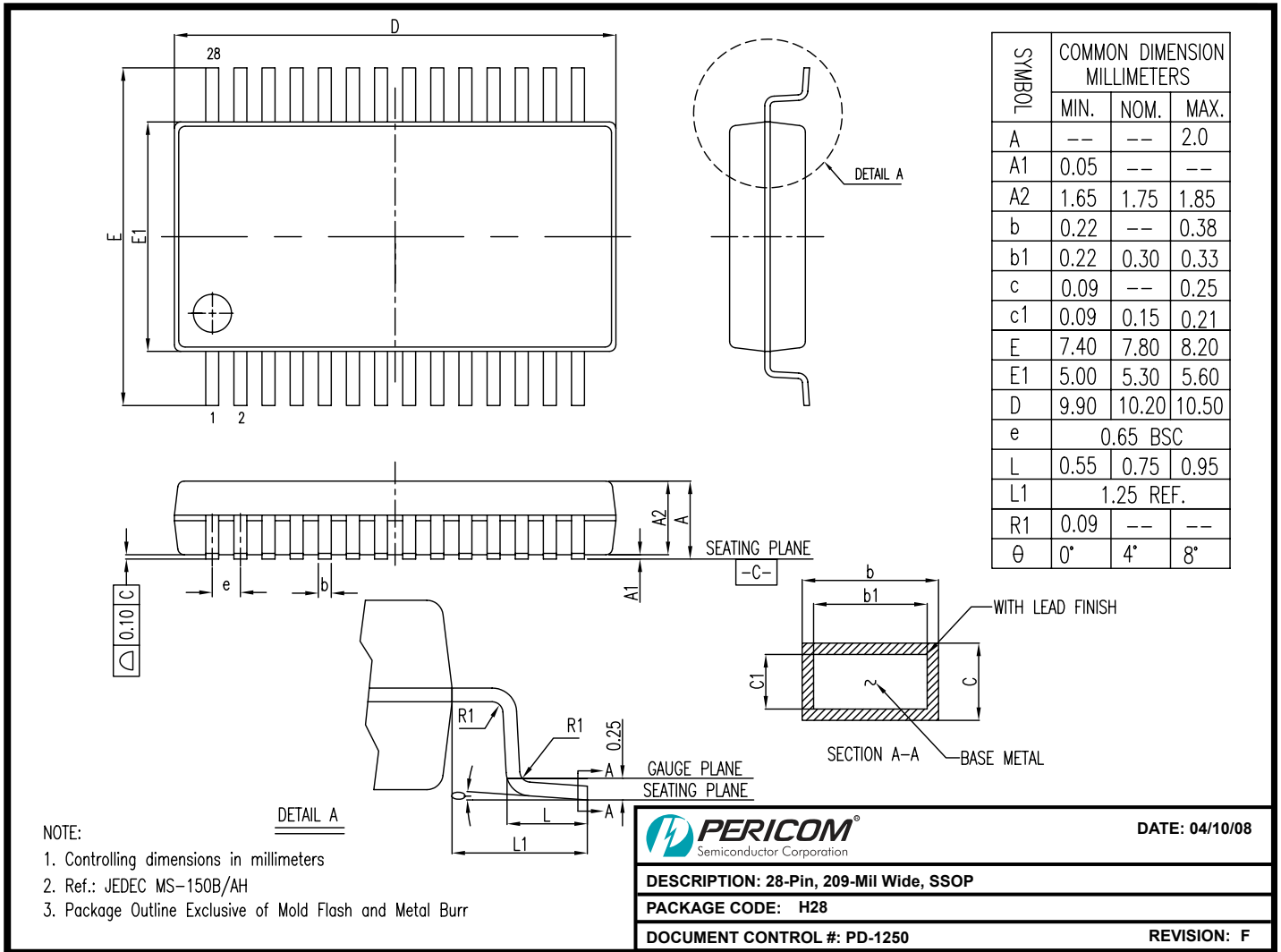

08-0143

PI6C20400B

Packaging Mechanical: 28-Pin TSSOP (L)

SYMBOLS	MIN.	NOM.	MAX.
A	–	–	1.20
A1	0.05	–	0.15
A2	0.80	1.00	1.05
b	0.19	–	0.30
c	0.09	–	0.20
D	9.60	9.70	9.80
E1	4.30	4.40	4.50
E	6.20	6.40	6.60
e	0.65 BSC		
L1	1.00 REF		
L	0.45	0.60	0.75
S	0.20	–	–
θ	0°	–	8°

NOTES:
 1. ALL DIMENSIONS IN MILLIMETERS. ANGLES IN DEGREES.
 2. JEDEC MO-153F
 3. DIMENSIONS DOES NOT INCLUDE MOLD FLASH, PROTRUSIONS OR GATE BURRS.

		DATE: 03/31/16
DESCRIPTION: 28-Pin, 173mil Wide TSSOP		
PACKAGE CODE: L (L28)		
DOCUMENT CONTROL #: PD-1313	REVISION: F	

16-0076

Note: For latest package info, please check: <http://www.pericom.com/support/packaging/packaging-mechanicals-and-thermal-characteristics/>

Ordering Information⁽¹⁻³⁾

Ordering Code	Package Code	Package Description
PI6C20400BHE	H	28-pin, 209-mil wide (SSOP)
PI6C20400BHEX	H	28-pin, 209-mil wide (SSOP), Tape & Reel
PI6C20400BLE	L	28-pin, 173-mil wide (TSSOP)
PI6C20400BLEX	L	28-pin, 173-mil wide (TSSOP), Tape & Reel

Notes:

1. Thermal characteristics can be found on the company web site at www.pericom.com/packaging/
2. E = Pb-free and Green
3. Adding an X suffix = Tape/Reel

IMPORTANT NOTICE

DIODES INCORPORATED MAKES NO WARRANTY OF ANY KIND, EXPRESS OR IMPLIED, WITH REGARDS TO THIS DOCUMENT, INCLUDING, BUT NOT LIMITED TO, THE IMPLIED WARRANTIES OF MERCHANTABILITY AND FITNESS FOR A PARTICULAR PURPOSE (AND THEIR EQUIVALENTS UNDER THE LAWS OF ANY JURISDICTION).

Diodes Incorporated and its subsidiaries reserve the right to make modifications, enhancements, improvements, corrections or other changes without further notice to this document and any product described herein. Diodes Incorporated does not assume any liability arising out of the application or use of this document or any product described herein; neither does Diodes Incorporated convey any license under its patent or trademark rights, nor the rights of others. Any Customer or user of this document or products described herein in such applications shall assume all risks of such use and will agree to hold Diodes Incorporated and all the companies whose products are represented on Diodes Incorporated website, harmless against all damages.

Diodes Incorporated does not warrant or accept any liability whatsoever in respect of any products purchased through unauthorized sales channel.

Should Customers purchase or use Diodes Incorporated products for any unintended or unauthorized application, Customers shall indemnify and hold Diodes Incorporated and its representatives harmless against all claims, damages, expenses, and attorney fees arising out of, directly or indirectly, any claim of personal injury or death associated with such unintended or unauthorized application.

Products described herein may be covered by one or more United States, international or foreign patents pending. Product names and markings noted herein may also be covered by one or more United States, international or foreign trademarks.

This document is written in English but may be translated into multiple languages for reference. Only the English version of this document is the final and definitive format released by Diodes Incorporated.

LIFE SUPPORT

Diodes Incorporated products are specifically not authorized for use as critical components in life support devices or systems without the express written approval of the Chief Executive Officer of Diodes Incorporated. As used herein:

A. Life support devices or systems are devices or systems which:

1. are intended to implant into the body, or

2. support or sustain life and whose failure to perform when properly used in accordance with instructions for use provided in the labeling can be reasonably expected to result in significant injury to the user.

B. A critical component is any component in a life support device or system whose failure to perform can be reasonably expected to cause the failure of the life support device or to affect its safety or effectiveness.

Customers represent that they have all necessary expertise in the safety and regulatory ramifications of their life support devices or systems, and acknowledge and agree that they are solely responsible for all legal, regulatory and safety-related requirements concerning their products and any use of Diodes Incorporated products in such safety-critical, life support devices or systems, notwithstanding any devices- or systems-related information or support that may be provided by Diodes Incorporated. Further, Customers must fully indemnify Diodes Incorporated and its representatives against any damages arising out of the use of Diodes Incorporated products in such safety-critical, life support devices or systems.

Copyright © 2016, Diodes Incorporated

www.diodes.com