



Chipsmall Limited consists of a professional team with an average of over 10 year of expertise in the distribution of electronic components. Based in Hongkong, we have already established firm and mutual-benefit business relationships with customers from,Europe,America and south Asia,supplying obsolete and hard-to-find components to meet their specific needs.

With the principle of “Quality Parts,Customers Priority,Honest Operation,and Considerate Service”,our business mainly focus on the distribution of electronic components. Line cards we deal with include Microchip,ALPS,ROHM,Xilinx,Pulse,ON,Everlight and Freescale. Main products comprise IC,Modules,Potentiometer,IC Socket,Relay,Connector.Our parts cover such applications as commercial,industrial, and automotives areas.

We are looking forward to setting up business relationship with you and hope to provide you with the best service and solution. Let us make a better world for our industry!



Contact us

Tel: +86-755-8981 8866 Fax: +86-755-8427 6832

Email & Skype: info@chipsmall.com Web: www.chipsmall.com

Address: A1208, Overseas Decoration Building, #122 Zhenhua RD., Futian, Shenzhen, China



Phase-Locked Loop Clock Driver

Product Features

- High-Performance Phase-Locked-Loop Clock Distribution for Networking,
- Synchronous DRAM modules for server/workstation/PC applications
- Allows Clock Input to have Spread Spectrum modulation for EMI reduction
- Zero Input-to-Output delay
- Low jitter: Cycle-to-Cycle jitter ± 100 ps max.
- On-chip series damping resistor at clock output drivers for low noise and EMI reduction
- Operates at 3.3V V_{CC}
- Wide range of Clock Frequencies up to 80 MHz
- Package (Pb-Free & Green): Plastic 8-pin SOIC Package (W)

Product Description

The PI6C2502 features a low-skew, low-jitter, phase-locked loop (PLL) clock driver. By connecting the feedback FB_OUT output to the feedback FB_IN input, the propagation delay from the CLK_IN input to any clock output will be nearly zero.

Application

If a system designer needs more than 16 outputs with the features just described, using two or more zero-delay buffers such as PI6C2509Q, and PI6C2510Q, is likely to be impractical. The device-to-device skew introduced can significantly reduce the performance. Pericom recommends the use of a zero-delay buffer and an eighteen output non-zero-delay buffer. As shown in Figure 1, this combination produces a zero-delay buffer with all the signal characteristics of the original zero-delay buffer, but with as many outputs as the non-zero-delay buffer part. For example, when combined with an eighteen output non-zero delay buffer, a system designer can create a seventeen-output zero-delay buffer.

Logic Block Diagram

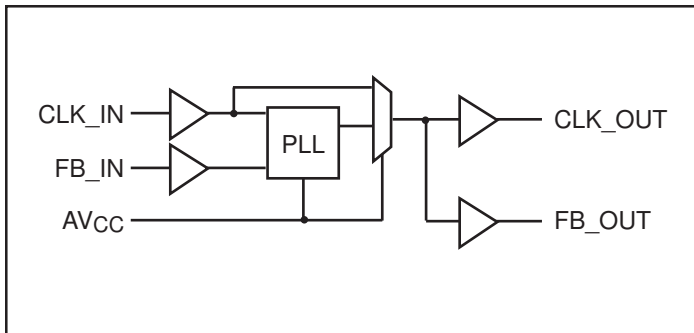

Product Pin Configuration

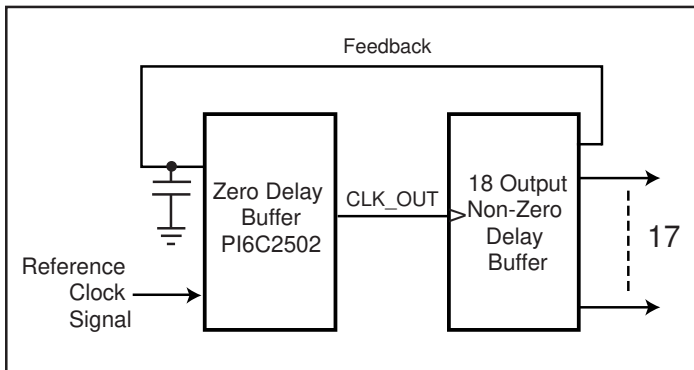
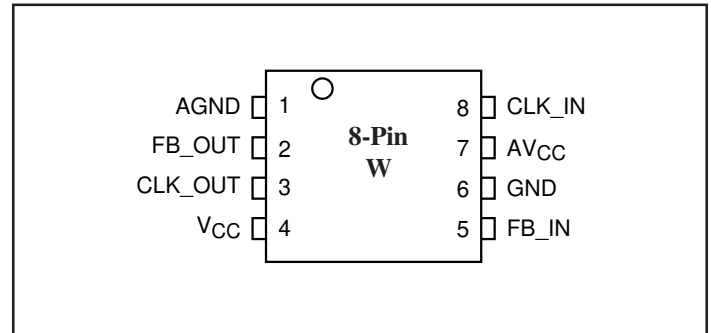

Figure 1. This Combination Provides Zero-Delay Between the Reference Clocks Signal and 17 Outputs

Pin Functions

Pin Name	Pin Number	Type	Description
CLK_IN	8	I	Reference Clock input. CLK_IN allows spread spectrum clock input.
FB_IN	5	I	Feedback input. FB_IN provides the feedback signal to the internal PLL.
FB_OUT	2	O	Feedback output FB_OUT is dedicated for external feedback. FB_OUT has an embedded series-damping resistor of the same value as the clock outputs CLK_OUT.
CLK_OUT	3	O	Clock outputs. These outputs provide low-skew copies of CLK_IN. Each output has an embedded series-damping resistor.
AV _{CC}	7	Power	Analog power supply. AV _{CC} can be also used to bypass the PLL for test purposes. When AV _{CC} is strapped to ground, PLL is bypassed and CLK_IN is buffered directly to the device outputs.
AGND	1	Ground	Analog ground. AGND provides the ground reference for the analog circuitry.
V _{CC}	4	Power	Power supply.
GND	6	Ground	Ground.

DC Specifications (Absolute maximum ratings over operating free-air temperature range)

Symbol	Parameter	Min.	Max.	Units
V _I	Input voltage range	-0.5	V _{CC} +0.5	V
V _O	Output voltage range			
I _{O,DC}	DC output current		100	mA
Power	Maximum power dissipation at T _A = 55°C in still air		1.0	W
T _{STG}	Storage temperature	-65	150	°C

Note: Stress beyond those listed under “absolute maximum ratings” may cause permanent damage to the device.

Parameter	Test Conditions	V _{CC}	Min.	Typ.	Max.	Units
I _{CC}	V _I = V _{CC} or GND; I _O = 0 ⁽¹⁾	3.6V			10	μA
C _I	V _I = V _{CC} or GND	3.3V		4		pF
C _O	V _O = V _{CC} or GND			6		

Note: 1. Continuous Output Current

Recommended Operating Conditions

Symbol	Parameter	Min.	Max.	Units
V _{CC}	Supply voltage	3.0	3.6	V
V _{IH}	High level input voltage	2.0		
V _{IL}	Low level input voltage		0.8	
V _I	Input voltage	0	V _{CC}	
T _A	Operating free-air temperature	0	70	°C

Electrical Characteristics

(Over recommended operating free-air temperature range Pull Up/Down Currents, V_{CC} = 3.0V)

Symbol	Parameter	Condition	Min.	Max.	Units
I _{OH}	Pull-up current	V _{OUT} = 2.4V		-18	mA
		V _{OUT} = 2.0V		-30	
I _{OL}	Pull-down current	V _{OUT} = 0.8V	25		
		V _{OUT} = 0.55V	17		

AC Specifications Timing Requirements

(Over recommended ranges of supply voltage and operating free-air temperature)

Symbol	Parameter	Min.	Max.	Units
F _{CLK}	Clock frequency	25	80	MHz
DC _{VI}	Input clock duty cycle	40	60	%
	Stabilization Time after power up		1	ms

Switching Characteristics

(Over recommended ranges of supply voltage and operating free-air temperature, C_L=30pF)

Parameter	From (Input)	To (Output)	V _{CC} = 3.3V ±0.3V, 0-70°C			Units
			Min.	Typ.	Max.	
t _{phase error without jitter}	CLK_IN↑ at 100MHz and 66MHz	FB_IN↑	-150		+150	ps
Jitter, cycle-to-cycle	At 100 MHz and 66 MHz	CLK_OUT	-100		+100	
Skew at 100 MHz and 66 MHz	CLK_OUT or FB_OUT	CLK_OUT or FB_OUT			200	
Duty cycle		CLK_OUT or FB_OUT	45		55	%
t _r , rise-time, 0.4V to 2.0V					1.0	ns
t _f , fall-time, 2.0V to 0.4V					1.1	

Note: These switching parameters are guaranteed by design.

Package Mechanical Information

Plastic 8-pin SOIC Package

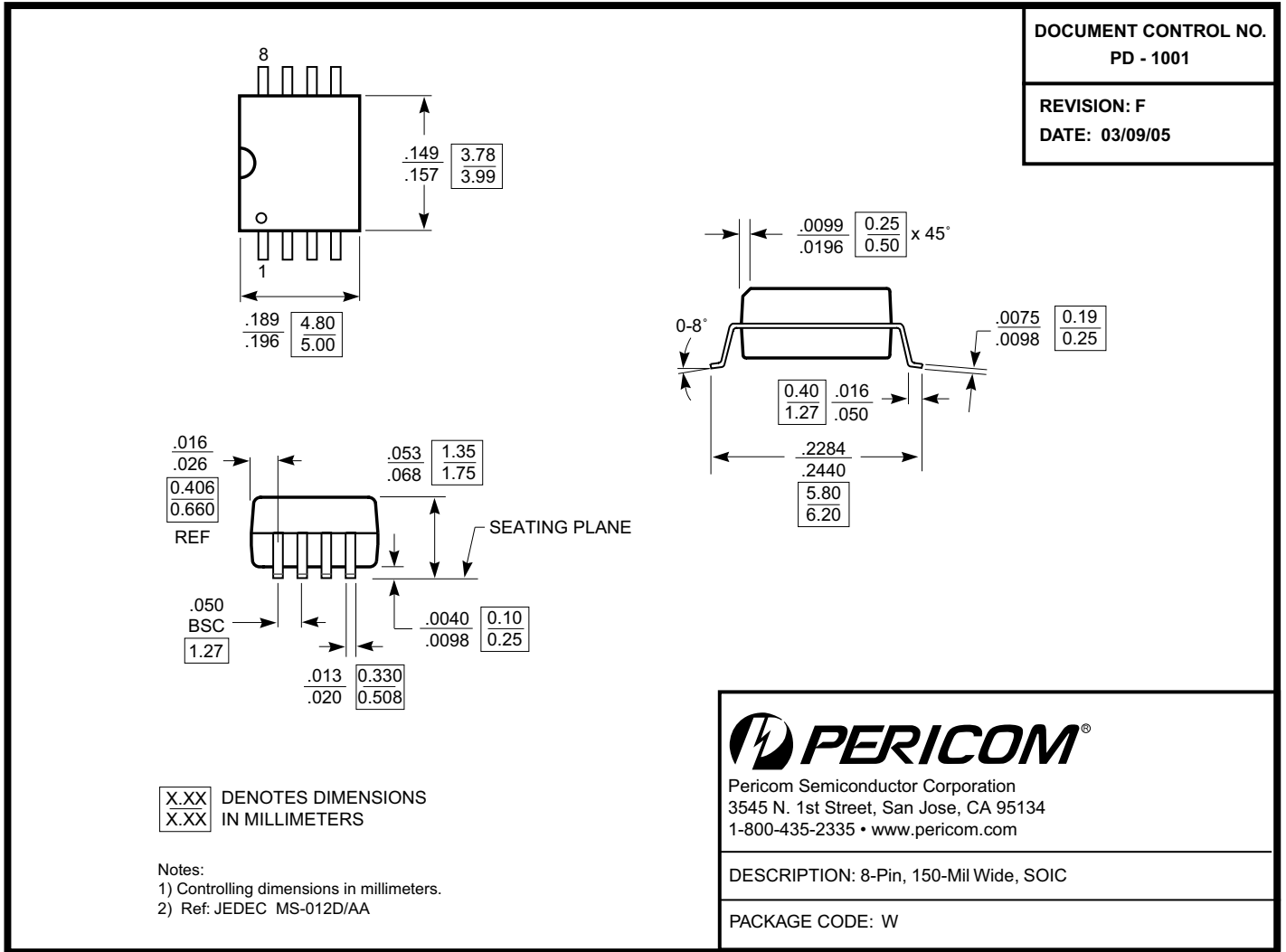

Ordering Information

Ordering Code	Package Name	Package Type	Operating Range
PI6C2502WE	W8	8-pin 150-mil SOIC, Pb-Free & Green	Commercial

Notes:

1. Thermal characteristics can be found on the company website at www.pericom.com/packaging/
2. X = Tape & Reel