



Chipsmall Limited consists of a professional team with an average of over 10 year of expertise in the distribution of electronic components. Based in Hongkong, we have already established firm and mutual-benefit business relationships with customers from,Europe,America and south Asia,supplying obsolete and hard-to-find components to meet their specific needs.

With the principle of “Quality Parts,Customers Priority,Honest Operation,and Considerate Service”,our business mainly focus on the distribution of electronic components. Line cards we deal with include Microchip,ALPS,ROHM,Xilinx,Pulse,ON,Everlight and Freescale. Main products comprise IC,Modules,Potentiometer,IC Socket,Relay,Connector.Our parts cover such applications as commercial,industrial, and automotives areas.

We are looking forward to setting up business relationship with you and hope to provide you with the best service and solution. Let us make a better world for our industry!



Contact us

Tel: +86-755-8981 8866 Fax: +86-755-8427 6832

Email & Skype: info@chipsmall.com Web: www.chipsmall.com

Address: A1208, Overseas Decoration Building, #122 Zhenhua RD., Futian, Shenzhen, China



Low Voltage PLL Clock Driver

Features

- Fully Integrated PLL
- Output Frequency up to 125 MHz
- Compatible with PowerPC and Pentium Microprocessors
- 3.3V_{VCC}
- +100ps Typical Cycle-to-Cycle Jitter
- Packaging (Pb-free & Green available):
-52-pin LQFP (FC)

Pin Configuration

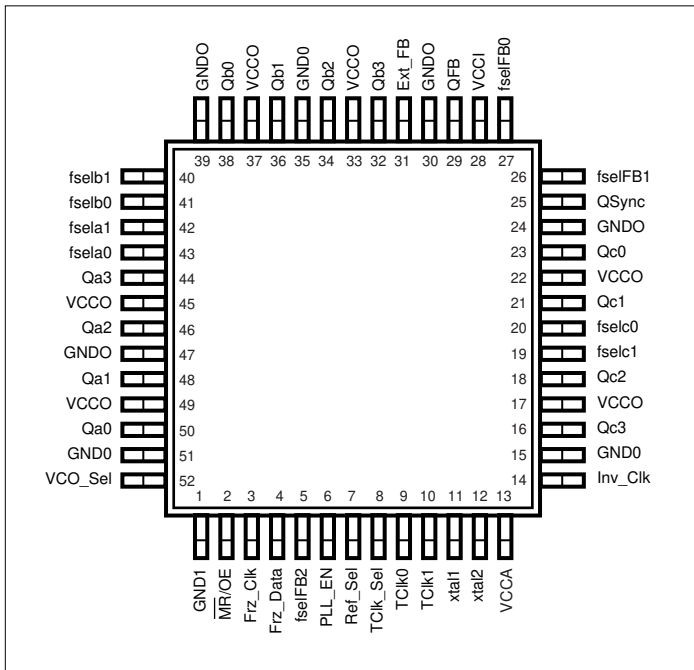

Description

The PI6C2972 are 3.3V compatible, PLL based clock driver devices targeted for high-performance CISC or RISC processor based systems. With output frequencies of up to 125 MHz and skews of 550ps the PI6C2972 are ideally suited for most synchronous systems. The devices offer twelve low skew outputs plus a feedback and sync output for added flexibility and ease of system implementation.

The PI6C2972 features an extensive level of frequency programmability between the 12 outputs as well as the input vs output relationships. Using the select lines output frequency ratios of 1:1, 2:1, 3:1, 3:2, 4:1, 4:3, 5:1, 5:2, 5:3, 6:1 and 6:5 between outputs can be realized by pulsing low one clock edge prior to the coincident edges of the Qa and Qc outputs. The Sync output will indicate when the coincident rising edges of the above relationships will occur. The Power-On Reset ensures proper programming if the frequency select pins are set at power up. If the fselFB2 pin is held high, it may be necessary to apply a reset after power-up to ensure synchronization between the QFB output and the other outputs. The internal power-on reset is designed to provide this function, but with power-up conditions being dependent, it is difficult to guarantee. All other conditions of the fsel pins will automatically synchronize during PLL lock acquisition.

The PI6C2972 offers a very flexible output enable/disable scheme. Note that all of the control inputs on the PI6C2972 have internal pull-up resistors.

The PI6C2972 is fully 3.3V compatible and requires no external loop filter components. All inputs accept LVCMOS/LVTTL compatible levels while the outputs provide LVCMOS levels with the capability to drive 50-ohm transmission lines. For series terminated lines each PI6C2972 output can drive two 50-ohm lines in parallel thus effectively doubling the fanout of the device.

Block Diagram

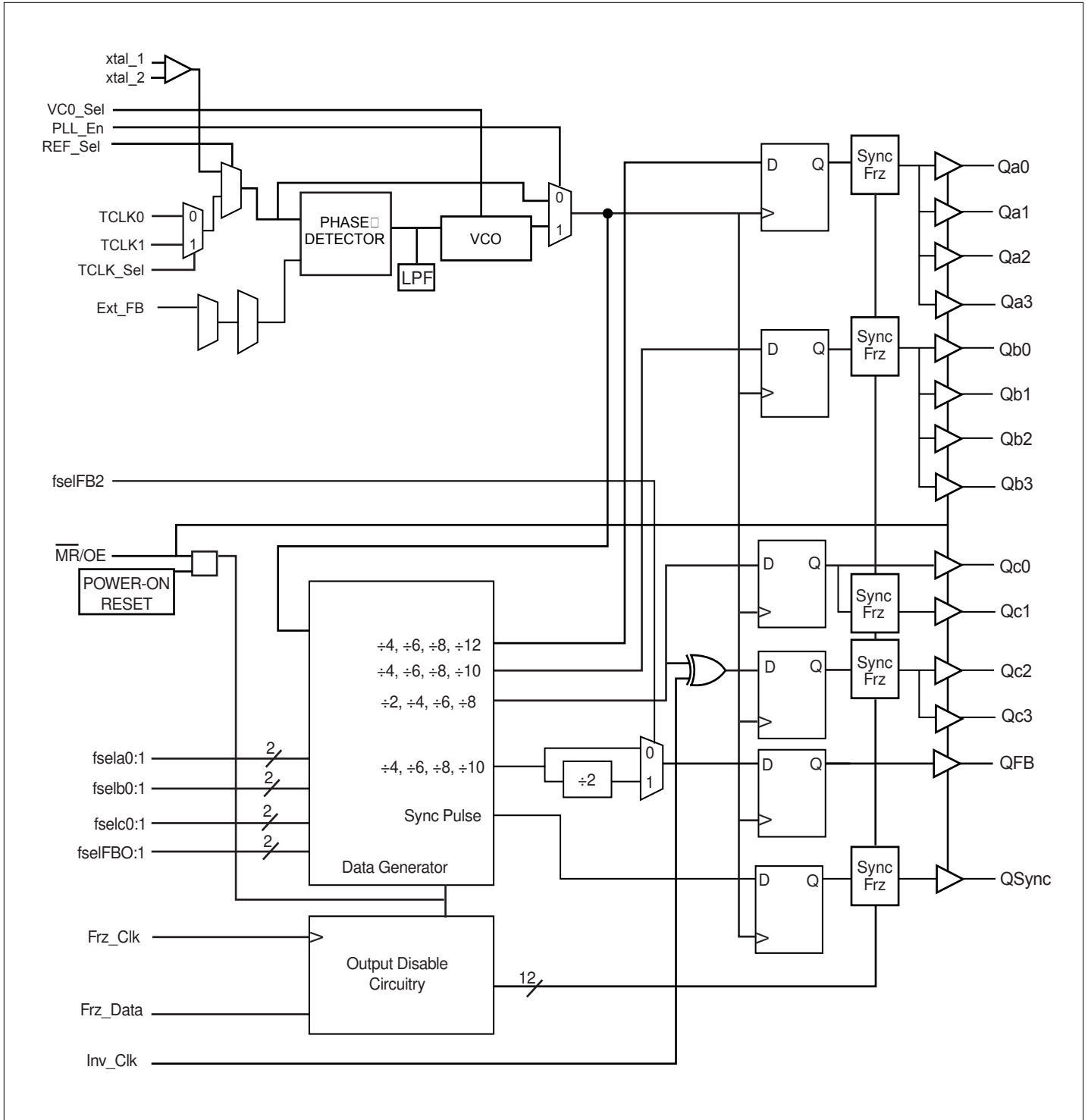

Function Table 1

fsla1	fsla0	Qa	fselb1	fselb0	Qb	fselc1	fselc0	Qc
0	0	÷4	0	0	÷4	0	0	÷2
0	1	÷6	0	1	÷6	0	1	÷4
1	0	÷8	1	0	÷8	1	0	÷6
1	1	÷12	1	1	÷10	1	1	÷8

Function Table 2

fselFB2	fselFB1	fselFB0	QFB
0	0	0	÷4
0	0	1	÷6
0	1	0	÷8
0	1	1	÷10
1	0	0	÷8
1	0	1	÷12
1	1	0	÷16
1	1	1	÷20

Function Table 3

Control Pin	Logic '0'	Logic '1'
VCO_Sel	VCO/2	VCO
Ref_Sel	TCLK	Xtal
TCLK_Sel	TCLK0	TCLK1
PLL_En	Bypass PLL	Enable PLL
MR/OE	Master Reset/Output Hi-Z	Enable Outputs
Inv_CLK	Non-Inverted Qc2, Qc3	Inverted Qc2, Qc3

Crystal Recommendations

Parameters	Value
Crystal Cut	Fundamental AT Cut
Resonance	Parallel Resonance
Freq. Tolernace	±100ppm @ 25°C
Freq. Temp. Stability	±175ppm (0° to 70°C)
Operating Range	0° to 70°C
Shunt Capacitance	< 7pF
ESR	< 40-Ohm
Drive Level	5mW
Aging	5ppm / Year (First 3 years)

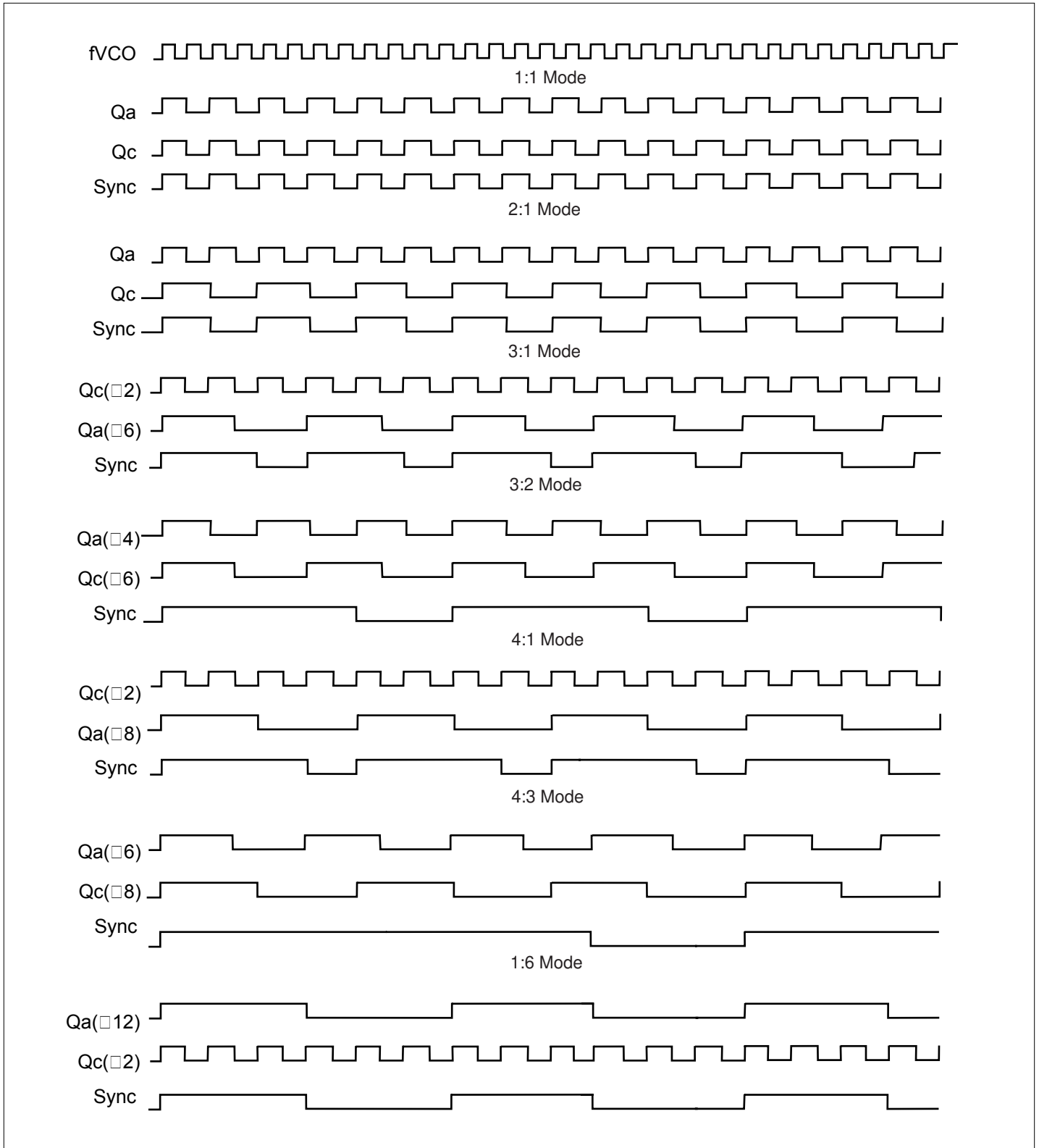
Timing Diagrams

Absolute Maximum Ratings

Symbol	Parameter	Min.	Max.	Units
V _{CC}	Supply Voltage	-0.3	4.6	V
V _I	Input Voltage	-0.3	V _{DD} + 0.3	V
I _{IN}	Input Current		±20	mA
T _{STOR}	Storage Temperature	-40	125	°C

*Absolute maximum continuous ratings are those values beyond which damage to the device may occur. Exposure to these conditions or conditions beyond those indicated may adversely affect device reliability. Functional operation under absolute-maximum-rated conditions is not implied.

DC Characteristics (T_A = 0°C to 70°C, V_{CC} = 3.3V ± 5%)(4)

Symbol	Conditions	Characteristic	Min.	Typ.	Max.	Units
V _{IH}		Input HIGH Voltage	2.0		3.6	V
V _{IL}		Input LOW Voltage			0.8	
V _{OH}	I _{OH} = 20mA ⁽²⁾	Output HIGH Voltage	2.4			
V _{OL}	I _{OL} = 20mA ⁽²⁾	Output LOW Voltage			0.5	
I _{IN}	Note 3	Input Current			±120	µA
I _{CC}		Maximum Quiescent Supply Current		190	215	mA
I _{CCA}		Analog V _{CC} Current		15	20	
C _{IN}		Input Capacitance			4	pF
C _{pd}	Per Output	Power Dissipation Capacitance		25		

Notes:

1. V_{CMR} is the difference from the most positive side of the differential input signal. Normal operation is obtained when the "High" input is within the V_{CMR} range and the input lies within the V_{PP} specification.
2. The PI6C2972 outputs can drive series or parallel terminated 50 Ohm (or 50 Ohm to V_{CC}/2) transmission lines on the incident edge.
3. Inputs have pull-up/pull-down resistors which affect input current.
4. Special thermal handling may be required in some configurations.

PLL Input Reference Characteristic (T_A = 0°C to 70°C)

Symbol	Conditions	Characteristics	Min.	Max.	Units
t _r , t _f		TCLK Input Rise/Falls		3.0	ns
f _{ref}	Note 5	Reference Input Frequency	Note 5	100, Note 5	MHz
f _{refDC}		Reference Input Duty Cycle	25	75	%
txtal		Crystal Oscillator Frequency	10	25	MHz

Notes:

5. Maximum input reference frequency is limited by the VCO lock range and the feedback divider or 100 MHz, minimum input reference frequency is limited by the VCO lock range and the feedback divider.

AC Characteristics (T_A = 0°C to 70°C, V_{CC} = 3.3V ± 5%)

Symbol	Characteristics	Conditions	Min.	Typ.	Max.	Units
t _r , t _f	Output Rise/Fall Time (Note7)	0.8 to 2.0V	0.15		1.2	ns
t _{pw}	Output Duty Cycle (Note7)		t _{CYCLE} /2 -750	t _{CYCLE} /2 ±500	t _{CYCLE} /2 +750	
t _{pd}	Propagation Delay Notes 7, 8, QFB = ÷8	TCLK0 TCLK1	-270 -330	130 70	530 470	ps
t _{os}	Output-to-Output Skew	Note 7			550	
f _{VCO}	VCO Lock Range		200		480	
f _{max}	Maximum Output Frequency Q (÷2) Q (÷4) Q (÷6) Q (÷8)	Note 7			125 120 80 60	MHz
t _{jitter}	Cycle-to-Cycle Jitter (Peak-to-Peak)			±100		ps
t _{PLZ} , t _{PHZ}	Output Disable Time		2		8	ns
t _{PZL} , t _{PZH}	Output ENable Time		2		10	ns
t _{lock}	Maximum PLL Lock Time				10	ms
f _{MAX}	Maximum Frz_Clk Frequency				20	MHz

Notes:

7. 50 Ohm transmission line terminated into V_{CC}/2

8. t_{pd} is specified for a 50 MHz input reference. The window will shrink/grow proportionally from the minimum limit with shorter/longer input reference periods. The t_{pd} does not include jitter.

Start Bit	D0	D1	D2	D3	D4	D5	D6	D7	D8	D9	D10	D11
-----------	----	----	----	----	----	----	----	----	----	----	-----	-----

D0–D3 are the control bits for Qa0–Qa3, respectively
D4–D7 are the control bits for Qb0–Qb3, respectively
D8–D10 are the control bits for Qc1–Qc3, respectively
D11 is the control bit for QSync

Freeze Data Input Protocol

Packaging Mechanical: 52-Pin LQFP (FC)

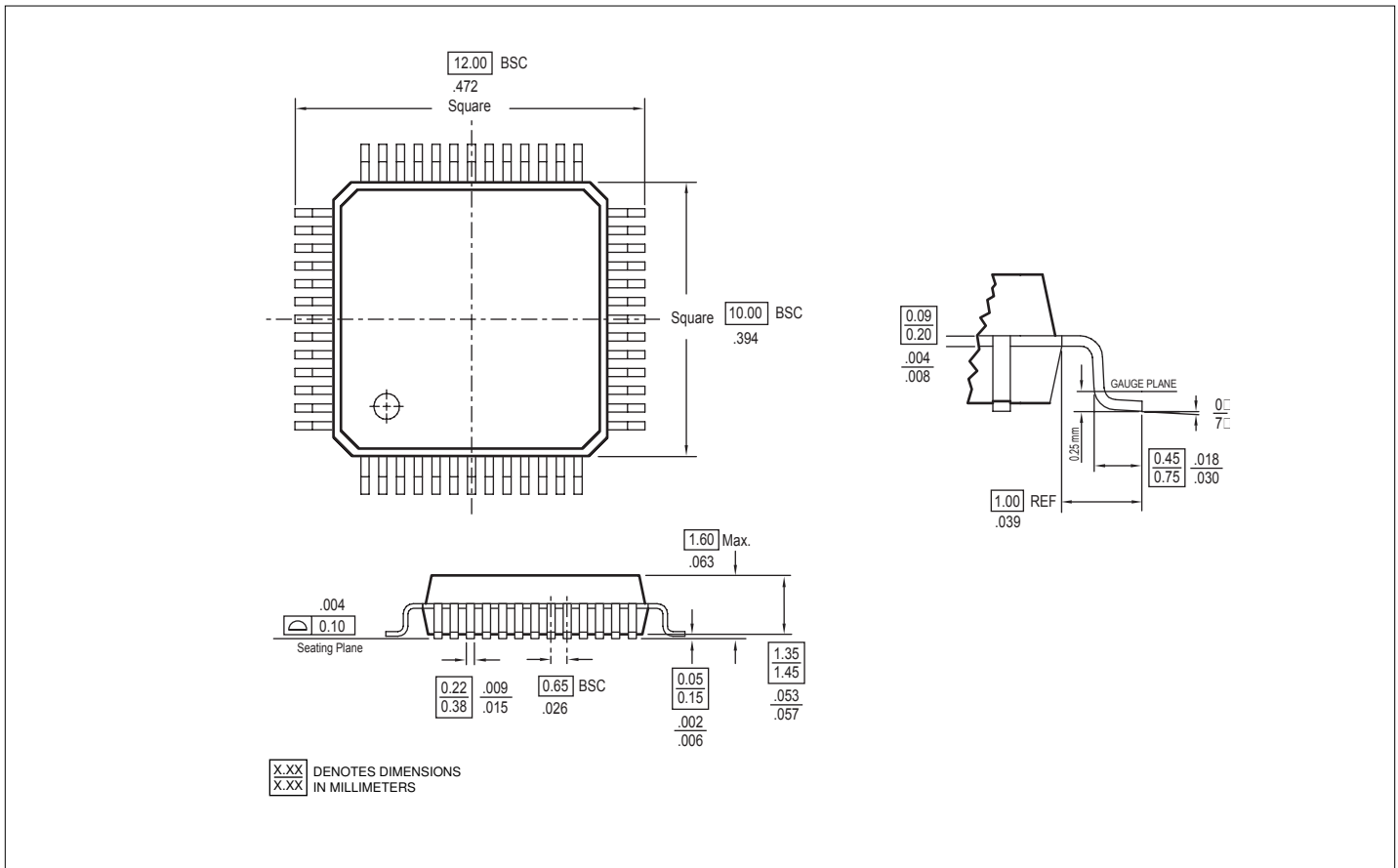

Ordering Information

Ordering Code	Package Code	Package Type
PI6C2972FC	FC	52-pin LQFP
PI6C2972FCE	FC	Pb-free & Green, 52-pin LQFP

Notes:

1. Thermal characteristics can be found on the company web site at www.pericom.com/packaging/