



Chipsmall Limited consists of a professional team with an average of over 10 year of expertise in the distribution of electronic components. Based in Hongkong, we have already established firm and mutual-benefit business relationships with customers from,Europe,America and south Asia,supplying obsolete and hard-to-find components to meet their specific needs.

With the principle of “Quality Parts,Customers Priority,Honest Operation,and Considerate Service”,our business mainly focus on the distribution of electronic components. Line cards we deal with include Microchip,ALPS,ROHM,Xilinx,Pulse,ON,Everlight and Freescale. Main products comprise IC,Modules,Potentiometer,IC Socket,Relay,Connector.Our parts cover such applications as commercial,industrial, and automotives areas.

We are looking forward to setting up business relationship with you and hope to provide you with the best service and solution. Let us make a better world for our industry!



Contact us

Tel: +86-755-8981 8866 Fax: +86-755-8427 6832

Email & Skype: info@chipsmall.com Web: www.chipsmall.com

Address: A1208, Overseas Decoration Building, #122 Zhenhua RD., Futian, Shenzhen, China



Features

- PI6C3Q99x family provides following products:
PI6C3Q991: 32-pin PLCC version
PI6C3Q993: 28-pin QSOP version
- Inputs are 5V Tolerant
- 4 pairs of programmable skew outputs
- Low skew: 200ps same pair; 250ps all outputs
- Selectable positive or negative edge synchronization:
Excellent for DSP applications
- Synchronous output enable
- Input frequency: 3.75 MHz to 85 MHz
- Output frequency: 15 MHz to 85MHz
- 2x, 4x, 1/2, and 1/4 outputs
- 3 skew grades:
PI6C3Q99x: $t_{SKEW0} < 750ps$
PI6C3Q99x-5: $t_{SKEW0} < 500ps$
PI6C3Q99x-2: $t_{SKEW0} < 250ps$
- 3-level inputs for skew and PLL range control
- PLL bypass for DC testing
- External feedback, internal loop filter
- 12mA balanced drive outputs
- Low Jitter: < 200ps peak-to-peak
- Industrial temperature range
- Packaging (Pb-free and Green available):
—32-pin PLCC
—28-pin QSOP

Description

The PI6C3Q99x family is a 3.3V PLL-based clock driver intended for high-performance computing and data-communication applications. A key feature of the programmable skew is the ability of outputs to lead or lag the REF input signal. The PI6C3Q991 has 8 programmable skew outputs in 4 banks of 2, while the PI6C3Q993 has 6 programmable skew outputs and 2 zero skew outputs. Skew is controlled by 3-level input signals that may be hard-wired to appropriate HIGH-MID-LOW levels.

When the GND/sOE pin is held LOW, all outputs are synchronously enabled. However, if GND/sOE is held HIGH, all outputs except 3Q0 and 3Q1 are synchronously disabled. Furthermore, when the VCCQ/PE is held HIGH, all outputs are synchronized with the positive edge of the REF clock input. When VCCQ/PE is held LOW, all outputs are synchronized with the negative edge of REF. Both devices have LVTTTL 12mA balanced drive outputs.

Pin Configurations

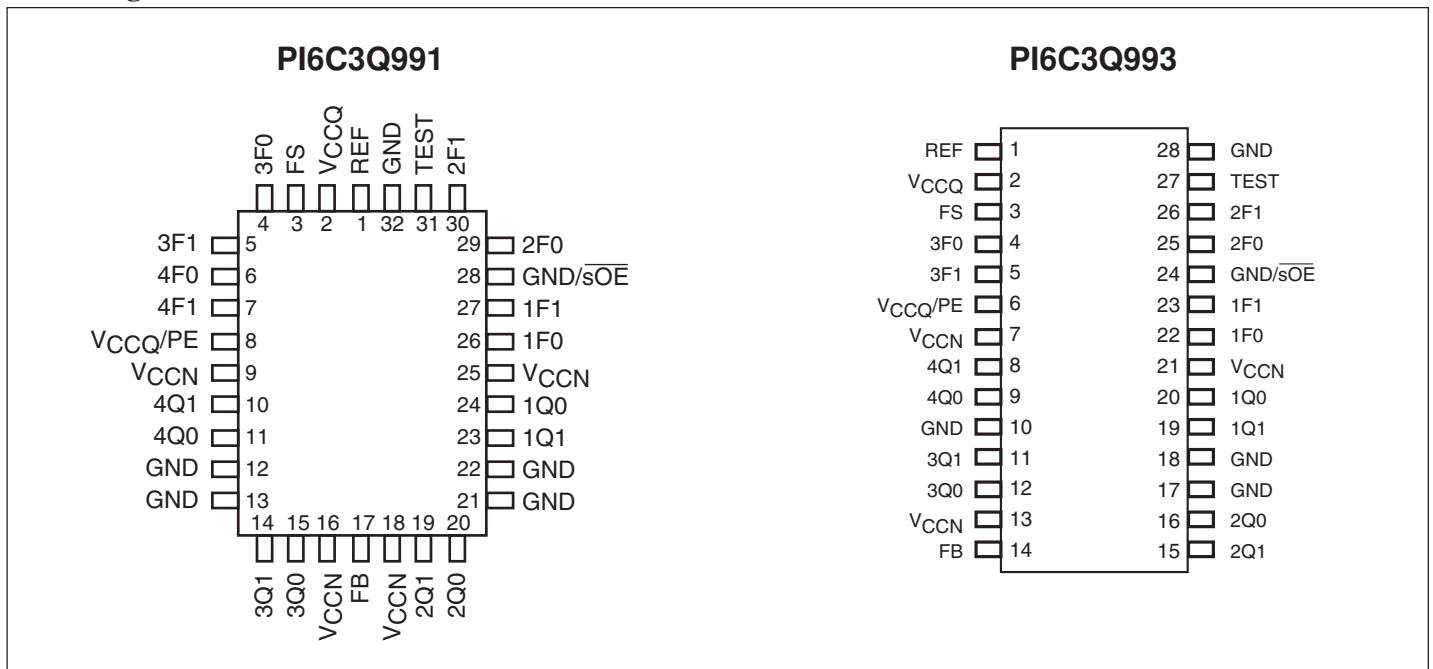

Logic Block Diagrams

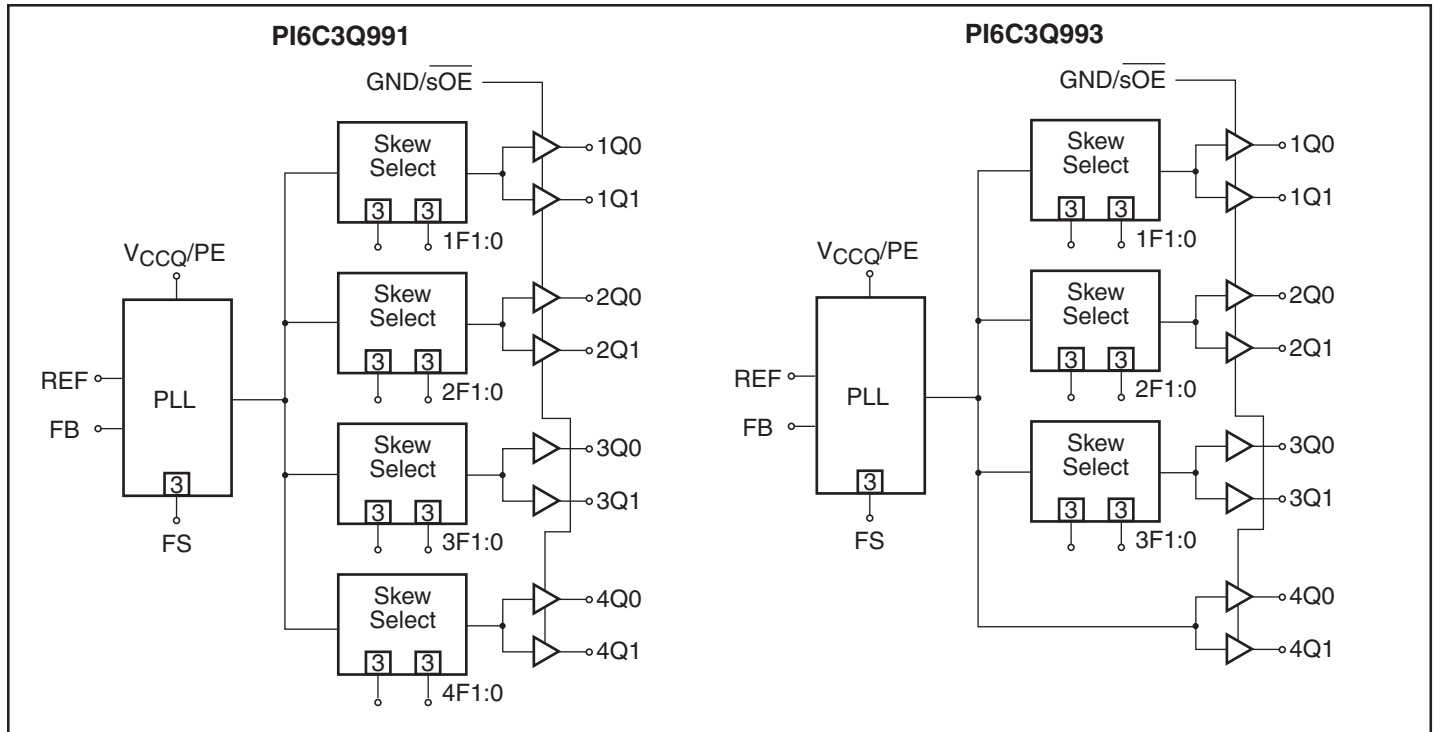

Table 1. Pin Descriptions

Pin Name	Type	Functional Description
REF	IN	Reference clock input
FB	IN	Feedback input
TEST ⁽¹⁾	IN	When TEST is held at MID level or HIGH level, the PLLi is disabled (except for conditions of Note 1). REF goes to all outputs. Skew selections (see table 3) remain in effect. Set LOW for normal operation.
GND/sOE ⁽¹⁾	IN	Synchronous output enable. When HIGH, it stops clock outputs (except 3Q0 and 3Q1) in a LOW state - 3Q0 or 3Q1 may be used as the feedback signal to maintain phase lock. When TEST is held at MID level and GND/sOE is HIGH, the nF [1:0] pins act as output disable controls for individual banks when nF [1:0] = LL. Set GND/sOE LOW for normal operation.
VCCQ/PE	IN	Selectable positive or negative edge control. When LOW/HIGH outputs are synchronized with the negative/positive edge of the reference clock.
nF [1:0]	IN	3-level inputs for selecting 1 of 9 skew taps or frequency range.
FS	IN	Selects appropriate oscillator circuit based on anticipated frequency range. See Table 2
nQ [1:0]	OUT	4 output banks of 2 outputs, with programmable skew. On the PI6C3Q993 4Q[1:0] are fixed zero skew outputs.
VCCN	PWR	Power supply for output buffers
VCCQ	PWR	Power supply for phase locked loop and other internal circuitry
GND	PWR	Ground

Note:

1. When TEST = MID and GND/sOE = HIGH, the PLL remains active with nF[1:0] =LL functioning as an output disable control for the individual output banks. See Table 3 for skew selections.

Programmable Skew

Output skew with respect to the REF input is adjustable to compensate for PCB trace delays, backplane propagation delays or to accommodate requirements for special timing relationships between clocked components. Skew is selectable as a multiple of time units - t_U which is of the order of a nanosecond (see Table 2). There are 9 skew configurations available for each output pair. These configurations are chosen by the nF[1:0] control pins. In order to minimize the number of control pins, 3-level inputs (HIGH-MID-LOW) are used, they are intended for but not restricted to hard-wiring. Undriven 3-level inputs default to the MID level. Where programmable skew is not a requirement, the control pins can be left open for the zero skew default setting. The skew selection Table (Table 3) shows how to select specific skew taps by using the nF[1:0] control pins.

External Feedback

By providing external feedback, the PI6C3Q99X family gives users flexibility with regard to skew adjustment. The FB signal is compared with the input REF signal at the phase detector in order to drive the V_{CO} . Phase differences causes the V_{CO} of the PLL to adjust up or down accordingly. An internal loop filter moderates the response of the V_{CO} to the phase detector. The loop filter transfer function has been chosen to provide minimal jitter (or frequency variation) while still providing accurate responses to input frequency.

Table 2. PLL Programmable Skew Range and Resolution Table

	FS = LOW	FS = MID	FS = HIGH
Timing unit calculation (t_U)	$1/(44 \times F_{NOM})$	$1/(26 \times F_{NOM})$	$1/(16 \times F_{NOM})$
V_{CO} frequency range (F_{NOM}) ^(2,3)	15 to 35 MHz	25 to 60 MHz	40 to 85 MHz
Skew adjustment range ⁽⁴⁾	$\pm 9.09\text{ns}$	$\pm 9.23\text{ns}$	$\pm 9.38\text{ns}$
Max. adjustment	$\pm 49^\circ$ $\pm 14\%$	$\pm 83^\circ$ $\pm 23\%$	$\pm 135^\circ$ $\pm 37\%$
Example 1, $F_{NOM} = 15$ MHz	$t_U = 1.52\text{ns}$		
Example 2, $F_{NOM} = 25$ MHz	$t_U = 0.91\text{ns}$	$t_U = 1.54\text{ns}$	
Example 3, $F_{NOM} = 30$ MHz	$t_U = 0.76\text{ns}$	$t_U = 1.28\text{ns}$	
Example 4, $F_{NOM} = 40$ MHz		$t_U = 0.96\text{ns}$	$t_U = 1.56\text{ns}$
Example 5, $F_{NOM} = 50$ MHz		$t_U = 0.77\text{ns}$	$t_U = 1.25\text{ns}$
Example 6, $F_{NOM} = 80$ MHz			$t_U = 0.78\text{ns}$

Notes:

2. The device may be operated outside recommended frequency ranges without damage, but functional operation is not guaranteed. Selecting the appropriate FS value based on input frequency range allows the PLL to operate in its 'sweet spot' where jitter is lowest.
3. The level on FS is determined by the nominal operating frequency of the V_{CO} and Time Unit Generator. The V_{CO} frequency appears at 1Q[1:0], 2Q[1:0], and the higher outputs when they are operated in undivided modes. The frequency appearing at REF and FB inputs are the same as the V_{CO} when the output is connected to FB undivided. The frequency of the REF and FB inputs are 1/2 or 1/4 the V_{CO} frequency when the part is configured for frequency multiplication by using a divided output as the FB input.
4. Skew adjustment range assumes that a zero skew output is used for feedback. If a skewed Q output is used for feedback, then adjustment range greater. For example if a $4t_U$ skewed output is used, all other outputs will be skewed by $-4t_U$ in addition to whatever skew value is programmed for those outputs. Max adjustment range applies to output pairs 3 and 4 where $\pm 6t_U$ skew adjustment is possible and at the lowest F_{NOM} value.

Table 3. Skew Selection Table for Output Pairs

nF1:0	Skew (Pair #1, #2)	Skew (Pair #3)	Skew (Pair #4) ⁽⁵⁾
LL ⁽⁶⁾	-4t _U	Divide by 2	Divide by 2
LM	-3t _U	-6t _U	-6t _U
LH	-2t _U	-4t _U	-4t _U
ML	-1t _U	-2t _U	-2t _U
MM	Zero skew	Zero skew	Zero skew
MH	+1t _U	+2t _U	+2t _U
HL	+2t _U	+4t _U	+4t _U
HM	+3t _U	+6t _U	+6t _U
HH	+4t _U	Divide by 4	Inverted ⁽⁷⁾

Notes:

5. Programmable skew on pair #4 is not applicable for the PI6C3Q993.
6. LL disables outputs if TEST = MID level and GND/sOE = HIGH.
7. When pair #4 is set to HH (inverted), GND/sOE disables pair #4 HIGH when V_{CCQ}/PE = HIGH, GND/sOE disables pair #4 LOW when V_{CCQ}/PE = LOW

Table 4. Absolute Maximum Ratings

Supply Voltage to Ground	-0.5V to 7.0V
Input Voltage	-0.5V to 7.0V
Maximum Power Dissipation at T _A = 85°C, PLCC	0.80 watts
QSOP	0.66 watts
T _{STG} Storage Temperature	-65°C to 150°C

Stresses above those listed under *Absolute Maximum Ratings* may cause permanent damage to the device. These ratings are stress specifications only and functional operation of the device at these or any other conditions above those listed in the operational sections of the specifications is not implied. Exposure to absolute maximum rating conditions for extended periods may affect product reliability.

Table 5. Recommended Operating Range

Symbol	Description	PI6C3Q99X/PI6C3Q99X-5 (Industrial)		PI6C3Q99X, PI6C3Q99X-2, PI6C3Q99X-5 (Commercial)		Units
		Min.	Max.	Min.	Max.	
V _{CC}	Power Supply Voltage	3.0	3.6	3.0	3.6	V
T _A	Ambient Operating Temperature	-40	85	0	70	°C

Table 6. DC Characteristics Over Operating Range

Symbol	Parameter	Test Condition	Min.	Max.	Units
V _{IH}	Input HIGH Voltage	Guaranteed Logic HIGH (REF, FB inputs only)	2.0	5.5	V
V _{IL}	Input LOW Voltage	Guaranteed Logic LOW (REF, FB inputs only)	-0.5	0.8	
V _{IHH}	Input HIGH Voltage ⁽⁸⁾	3-Level Inputs only	V _{CC} -0.6		
V _{IMM}	Input MID Voltage ⁽⁸⁾	3-Level Inputs only	V _{CC} /2-0.3	V _{CC} /2+0.3	
V _{ILL}	Input LOW Voltage ⁽⁸⁾	3-Level Inputs only		0.6	
I _{IN}	Input Leakage Current (REF, FB inputs only)	V _{IN} = V _{CC} or GND, V _{CC} = Max.		5	uA
I ₃	3-Level Input DC Current (TEST, FS, nF1:0)	V _{IN} = V _{CC} or GND, V _{CC} = Max.	HIGH level MID Level LOW Level	200 50 200	
I _{PU}	Input Pull-Up Current (V _{CCQ} /PE)	V _{CC} = Max, V _{IN} = GND		100	
I _{PD}	Input Pull-Down Current (GND/s \overline{OE})	V _{CC} = Max, V _{IN} = V _{CC}		100	
V _{OH}	Output HIGH Voltage	V _{CC} = Min, I _{OH} = -12mA	2.2		
V _{OL}	Output LOW Voltage	V _{CC} = Min, I _{OL} = 12mA		0.55	

Table 7. Power Supply Characteristics

Symbol	Parameter	Test Conditions	Typ.	Max.	Units
I _{CCQ}	Quiescent Power Supply Current	V _{CC} = Max, TEST = Mid., REF = LOW, GND/s \overline{OE} = LOW, All outputs unloaded	8.0	15	mA
ΔI _{CCN}	Power Supply Current per Input HIGH ⁽⁹⁾	V _{CC} = Max V _{IN} = 3.0V	1.0	30	μA
I _{CCD}	Dynamic Power Supply Current per Output ⁽⁹⁾	V _{CC} = Max C _L = 0pF	55	125	μA/ MHz
I _C	Total Power Supply Current ⁽⁹⁾	V _{CC} = 3.3V, F _{REF} = 20MHz, C _L = 160pF ⁽¹⁰⁾	29		mA
I _C	Total Power Supply Current ⁽⁹⁾	V _{CC} = 3.3V, F _{REF} = 33MHz, C _L = 160pF ⁽¹⁰⁾	42		
I _C	Total Power Supply Current ⁽⁹⁾	V _{CC} = 3.3V, F _{REF} = 66MHz, C _L = 160pF ⁽¹⁰⁾	76		

Notes:

8. Inputs are wired to V_{CC}, GND, or unconnected. Internal termination resistors bias unconnected inputs to V_{CC}/2. If inputs are switched, the function and timing of the outputs may glitched, and the PLL may require additional time before datasheet specifications are achieved.
9. Guaranteed by characterization but not production tested.
10. For 8 outputs each loaded with C_L = 20pF.

Table 8. Capacitance ($T_A = 25^\circ\text{C}$, $f = 1\text{ MHz}$, $V_{IN} = 0\text{V}$)

	QSOP		PLCC		Units
	Typ.	Max.	Typ.	Max.	
C_N	4	6	5	7	pF

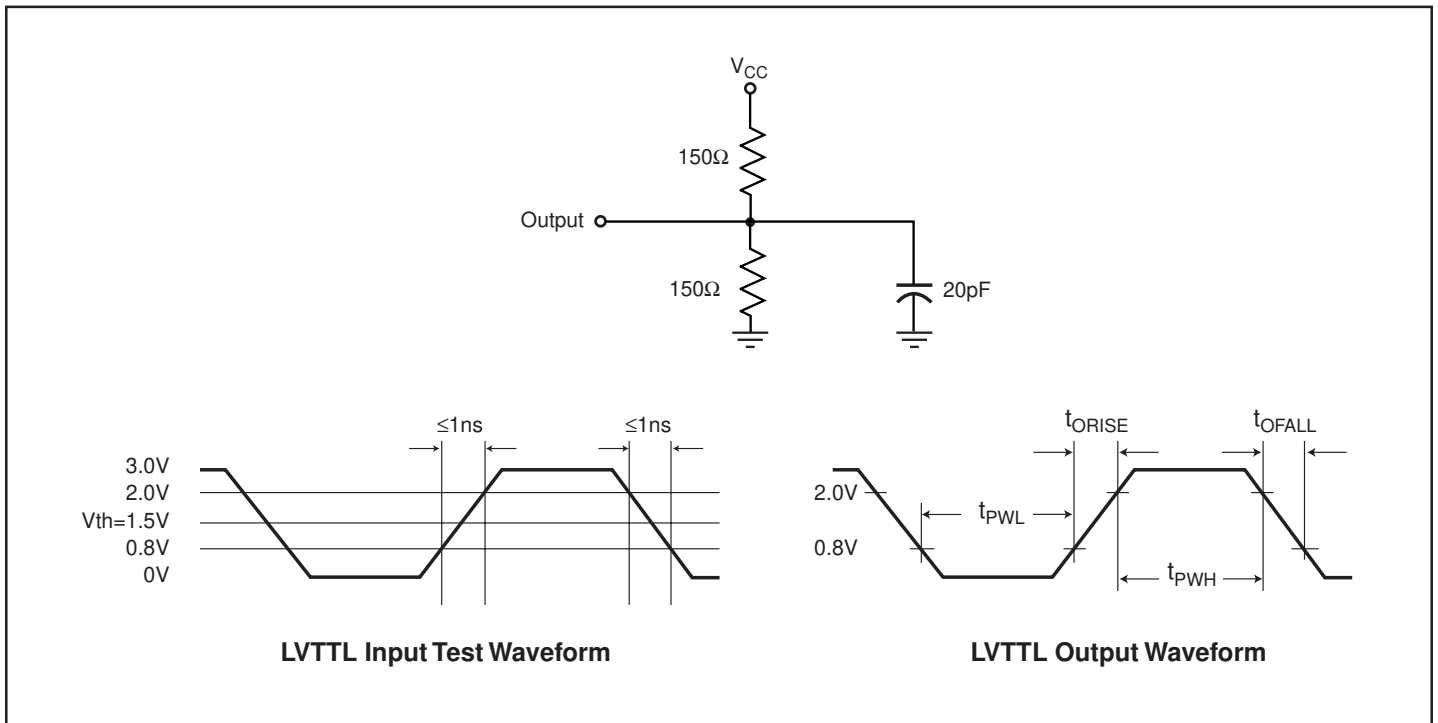

Table 9. Switching Characteristics Over Operating Range

Symbol	Description	PI6C3Q991-2 PI6C3Q993-2			PI6C3Q991-5 PI6C3Q993-5			PI6C3Q991 PI6C3Q993			Unit
		Min.	Typ.	Max.	Min.	Typ.	Max.	Min.	Typ.	Max.	
F _{NOM}	V _{CO} frequency range	see Table 2			see Table 2			see Table 2			
t _{RPWH}	REF pulse width HIGH ⁽²¹⁾	3.0			3.0			3.0			ns
t _{RPWL}	REF pulse width LOW ⁽²¹⁾	3.0			3.0			3.0			
t _U	Programmable skew time unit	see Table 3			see Table 3			see Table 3			
t _{SKEWPR}	Zero output matched-pair skew (xQ0, xQ1) ^(11,12,13)		0.05	0.20		0.1	0.25		0.1	0.25	ns
t _{SKEW0}	Zero output skew (all outputs) C _L = 0pF ^(11,14)		0.1	0.25		0.25	0.5		0.3	0.75	
t _{SKEW1}	Output skew (rise-rise, fall-fall, same class outputs) ^(11,15)		0.25	0.50		0.6	0.7		0.6	1.0	
t _{SKEW2}	Output skew (rise-fall, nominal-inverted, divided-divided) ^(11,15)		0.30	1.2		0.5	1.2		1.0	1.5	
t _{SKEW3}	Output skew (rise-rise, fall-fall, different class outputs) ^(11,15)		0.25	0.50		0.5	0.7		0.7	1.2	
t _{SKEW4}	Output skew (rise-fall, nominal-divided, divided inverted) ^(11,15)		0.50	0.90		0.5	1.0		1.2	1.7	
t _{DEV}	Device-to-device skew ^(11,12,16)			0.75			1.25			1.65	
t _{PD}	REF input to FB propagation delay ^(11,18)	-0.25	0	0.25	-0.5	0	0.5	-0.7	0	0.7	
t _{ODCV}	Output duty cycle variation from 50% ⁽¹¹⁾	-1.2	0	1.2	-1.2	0	1.2	-1.2	0	1.2	
t _{PWH}	Output HIGH time deviation from 50% ^(11,19)			2.0			2.5			3.0	
t _{PWL}	Output LOW time deviation from 50% ^(11,20)			1.5			3.0			3.5	
t _{ORISE}	Output rise time ⁽¹¹⁾	0.15	1.0	1.5	0.15	1.0	1.5	0.15	1.5	2.5	
t _{OFALL}	Output fall time ⁽¹¹⁾	0.15	1.0	1.5	0.15	1.0	1.5	0.15	1.5	2.5	
t _{LOCK}	PLL lock time ^(11,17)			0.5			0.5			0.5	ms
t _{JR}	Cycle-to-cycle output jitter ⁽¹¹⁾	RMS		25			40			40	ps
		Peak-to-peak		200			200			200	

Notes:

11. All timing tolerances apply for F_{NOM} ≥ 25MHz. Guaranteed by design and characterization.
12. Skew is the time between the earliest and the latest output transition among all outputs for which the same t_U delay has been selected when all are loaded with the specified load.
13. t_{SKEWPR} is the skew between a pair of outputs (xQ0 and xQ1) when all eight outputs are selected for 0t_U.
14. t_{SKEW0} is the skew between outputs when they are selected for 0t_U.
15. There are 3 classes of outputs: Nominal (multiple of t_U delay), Inverted (4Q0 and 4Q1 only with 4F0 = 4F1 = HIGH), and Divided (3Qx and 4Qx only in Divide-by-2 or Divide-by-4 mode).
16. t_{DEV} is output-to-output skew between any two devices operating under the same conditions (V_{CC}, ambient temperature, air flow, etc.)
17. t_{LOCK} is time required before synchronization is achieved. This specification is valid only after V_{CC} is stable & within normal operating limits. This parameter is measured from the application of a new signal or frequency at REF or FB until t_{PD} is within specified limits.
18. t_{PD} is measured with REF input rise and fall times (from 0.8V to 2.0V) of 1.0ns.
19. Measured at 2.0V.
20. Measured at 0.8V.
21. Refer to Table10 for more detail.

Table 10. Input Timing Requirements⁽²²⁾

Symbol	Description	Min.	Max.	Units
t_R, t_F	Maximum input rise and fall times, 0.8V to 2.0V		10	ns/V
t_{PWC}	Input clock pulse, HIGH or LOW	3		ns
D_H	Input duty cycle	10	90	%

Notes:

22. Input timing requirements are guaranteed by design. Where pulse width implied by D_H is less than t_{PWC} limit, t_{PWC} limit applies.

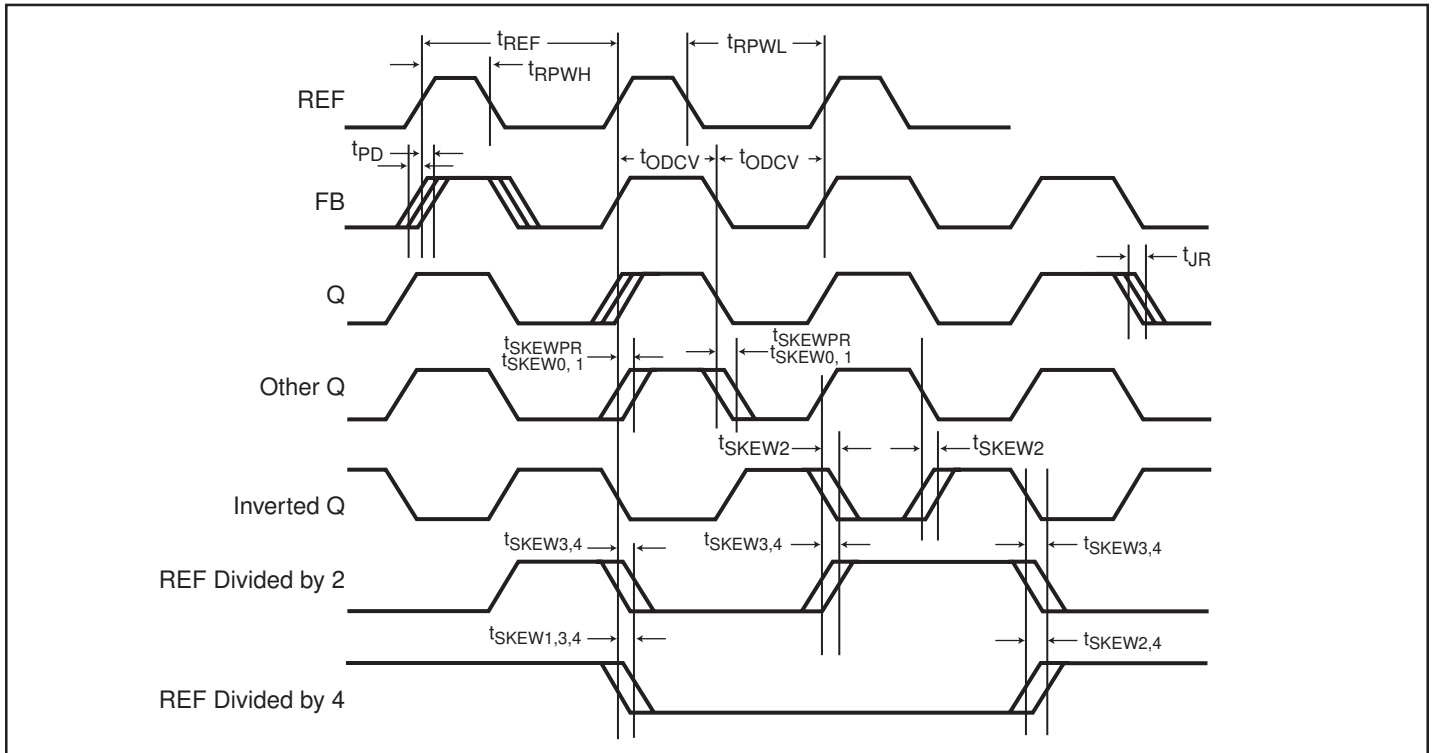
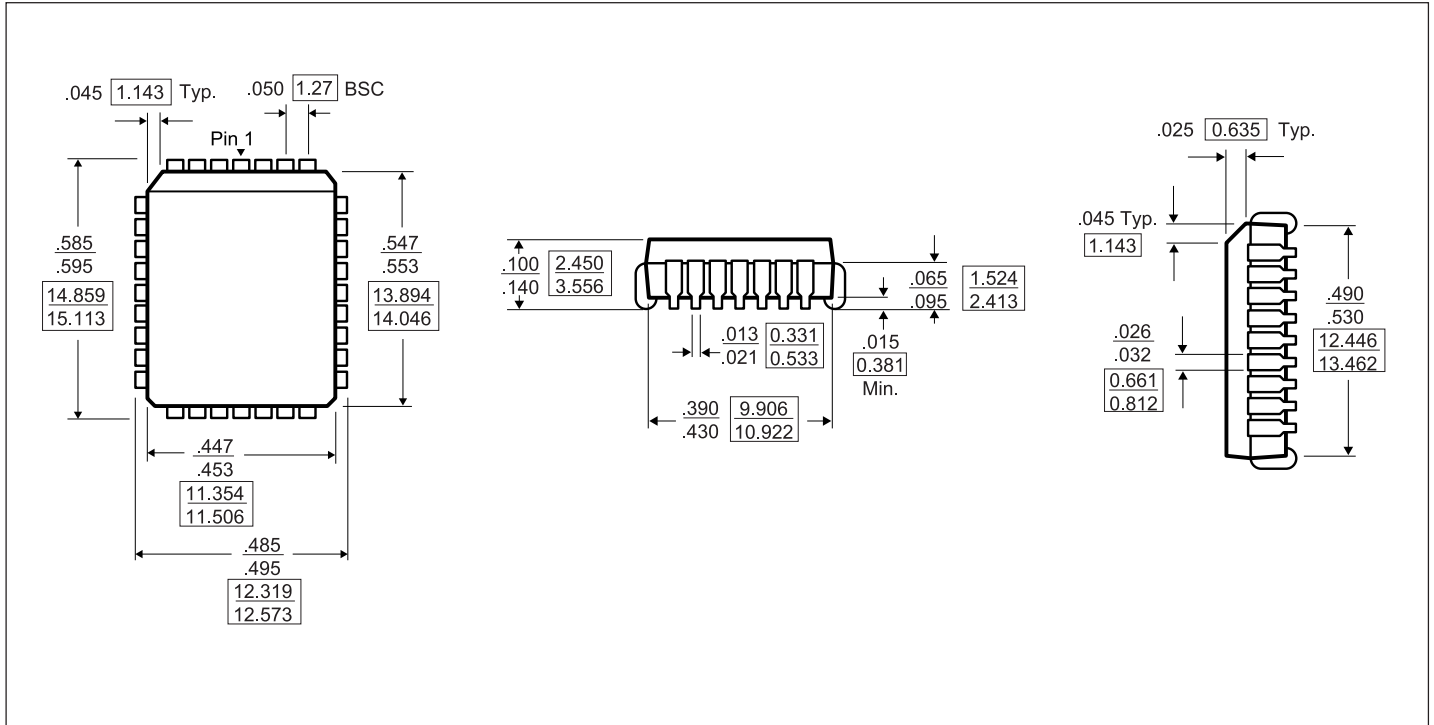

Figure 2. AC Timing Diagram

Notes:

- $V_{CCQ/PE}$:** The AC timing diagram above applies to $V_{CCQ/PE}=V_{CC}$. For $V_{CCQ/PE}=GND$, the negative edge of FB aligns with the negative edge of REF, divided outputs change on the negative edge of REF, and the positive edges of the divide-by-2 and the divide-by-4 signals align.
- Skew:** The time between the earliest and the latest output transition among all outputs for which the same t_U delay has been selected when all are loaded with 20pF and terminated with 75ohms to $V_{CC}/2$.
- t_{SKEWPR} :** The skew between a pair of outputs (xQ0 and xQ1) when all eight outputs are selected for 0t_U.
- t_{SKEW0} :** The skew between outputs when they are selected for 0t_U.
- tDEV:** The output-to-output skew between any two devices operating under the same conditions (V_{CC} , ambient temperature, air flow, etc.)
- tODCV:** The deviation of the output from a 50% duty cycle. Output pulse width variations are included in t_{SKEW2} and t_{SKEW4} specifications.
- tLOCK:** The time that is required before synchronization is achieved. This specification is valid only after V_{CC} is stable and within normal operating limits. This parameter is measured from the application of a new signal or frequency at REF or FB until t_{PD} is within specified limits.
- tPWH** is measured at 2.0V.
- tPWL** is measured at 0.8V.
- tORISE & tOFALL** are measured between 0.8V and 2.0V.

Packaging Mechanical: 32-Pin PLCC



Packaging Mechanical: 28-Pin QSOP

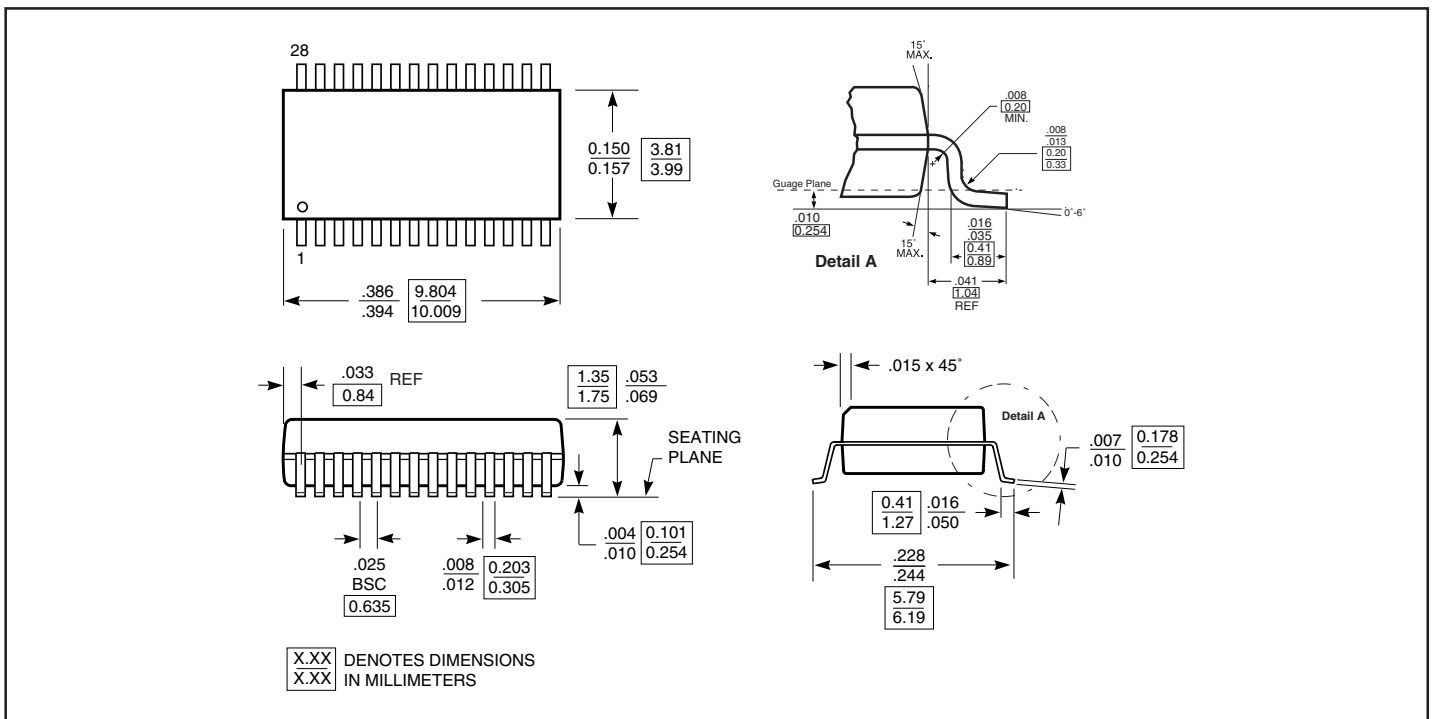



Ordering Information

Ordering Code	Package Code	Package Type	Operating Range
PI6C3Q991J	J	32-Pin PLCC	Commercial
PI6C3Q991-2J	J	32-Pin PLCC	
PI6C3Q991-5J	J	32-Pin PLCC	
PI6C3Q991-IJ	J	32-Pin PLCC	Industrial
PI6C3Q991-5IJ	J	32-Pin PLCC	
PI6C3Q991-5IJE	J	Pb-free & Green 32-Pin PLCC	
PI6C3Q993-2Q	Q	28-Pin QSOP	Commercial
PI6C3Q993-5QE	Q	Pb-free & Green 28-Pin QSOP	
PI6C3Q993-IQ	Q	28-Pin QSOP	Industrial
PI6C3Q993-5IQ	Q	28-Pin QSOP	

Notes:

- Thermal characteristics can be found on the company web site at www.pericom.com/packaging/
- E = Pb-free & Green
- X suffix = Tape/Reel