



Chipsmall Limited consists of a professional team with an average of over 10 year of expertise in the distribution of electronic components. Based in Hongkong, we have already established firm and mutual-benefit business relationships with customers from,Europe,America and south Asia,supplying obsolete and hard-to-find components to meet their specific needs.

With the principle of "Quality Parts,Customers Priority,Honest Operation,and Considerate Service",our business mainly focus on the distribution of electronic components. Line cards we deal with include Microchip,ALPS,ROHM,Xilinx,Pulse,ON,Everlight and Freescale. Main products comprise IC,Modules,Potentiometer,IC Socket,Relay,Connector.Our parts cover such applications as commercial,industrial, and automotives areas.

We are looking forward to setting up business relationship with you and hope to provide you with the best service and solution. Let us make a better world for our industry!



Contact us

Tel: +86-755-8981 8866 Fax: +86-755-8427 6832

Email & Skype: info@chipsmall.com Web: www.chipsmall.com

Address: A1208, Overseas Decoration Building, #122 Zhenhua RD., Futian, Shenzhen, China



3.3V Low Skew 1-to-4 Crystal/LVCMOS to LVPECL Fanout Buffer

Features

- Maximum operation frequency: 500MHz
- 4 pair of differential LVPECL outputs
- Selectable CLK and crystal inputs
- CLK accepts LVCMOS, LVTTTL input level
- Output Skew: 30ps (maximum)
- Part-to-part skew: 150ps (maximum)
- Propagation delay: 1.5ns (maximum)
- 3.3V power supply
- Pin-to-pin compatible to ICS8535-11
- Operating Temperature: -40°C to 85°C
- Packaging (Pb-free & Green available):
- 20-pin TSSOP (L)

Description

The PI6C48535-11 is a high-performance low-skew LVPECL fanout buffer. PI6C48535-11 features selectable of single-ended clock or crystal inputs and translates to four LVPECL outputs. The CLK input accepts LVCMOS or LVTTTL signals. The outputs are synchronized with input clock during asynchronous assertion /deassertion of CLK_EN pin. PI6C48535-11 is ideal for crystal or LVCMOS/LVTTTL to LVPECL translation. Typical clock translation and distribution applications are data-communications and telecommunications.

Block Diagram

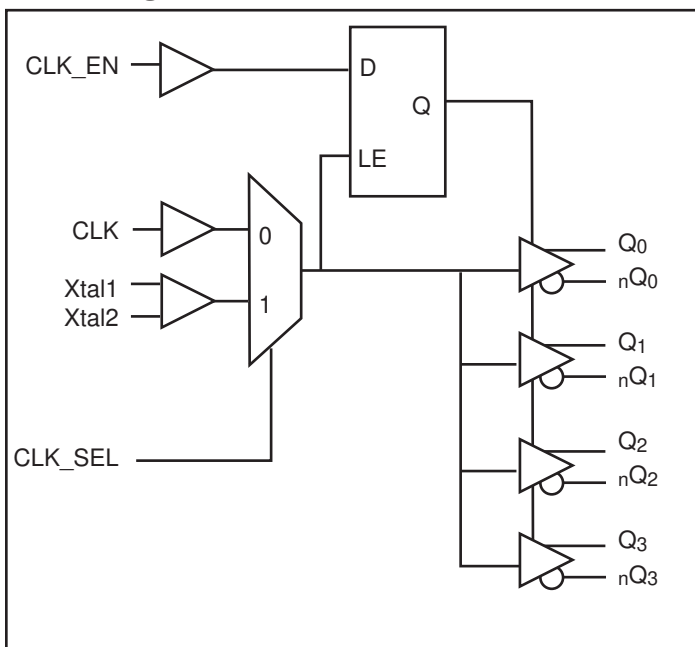

Pin Diagram

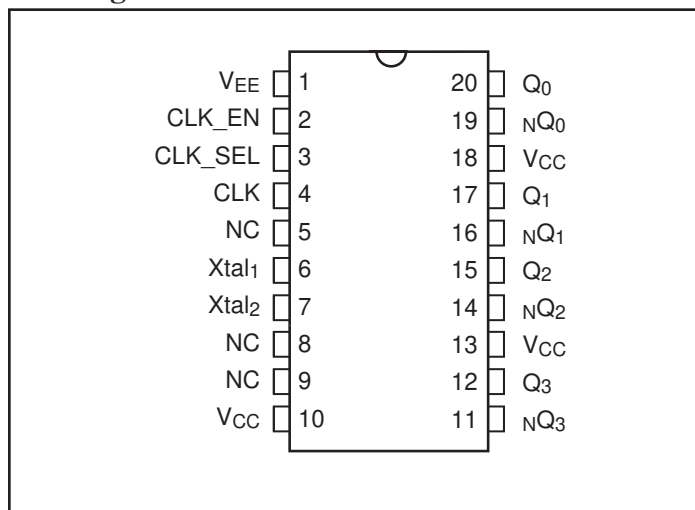

Pin Description

Name	Pin #	Type	Description
V _{EE}	1	P	Connect to Negative power supply
CLK_EN	2	I_PU	Synchronizing clock enable. When high, clock outputs follow clock input. When low, Q _x outputs are forced low, nQ _x outputs are forced high. LVCMOS/LVTTL level with 50KΩ pull up.
CLK_SEL	3	I_PD	Clock select input. When high, selects Xtal (Xtal1, Xtal2) inputs. When low, selects CLK input. LVCMOS/LVTTL level with 50KΩ pull down.
CLK	4	I_PD	LVCMOS / LVTTL clock input
Xtal1, Xtal2	6, 7		Crystal input and output
NC	5, 8, 9		No internal connection.
V _{CC}	10, 13, 18	P	Connect to 3.3V
Q ₃ , nQ ₃	11, 12	O	Differential output pair, LVPECL interface level.
Q ₂ , nQ ₂	14, 15	O	Differential output pair, LVPECL interface level.
Q ₁ , nQ ₁	16, 17	O	Differential output pair, LVPECL interface level.
Q ₀ , nQ ₀	19, 20	O	Differential output pair, LVPECL interface level.

Notes:

1. I = Input, O = Output, P = Power supply connection, I_PD = Input with pull down, I_PU = Input with pull up

Pin Characteristics

Symbol	Parameter	Conditions	Min.	Typ.	Max.	Units
C _{IN}	Input Capacitance				4	pF
R _{pullup}	Input Pullup Resistance			50		KΩ
R _{pulldown}	Input Pulldown Resistance			50		KΩ

Control Input Function Table

Inputs			Outputs	
CLK_EN	CLK_SEL	Selected Source	Q ₀ :Q ₃	nQ ₀ :nQ ₃
0	0	CLK	Diabld: Low	Diabld: High
0	1	Xtal1, Xtal2	Diabld: Low	Diabld: High
1	0	CLK	Enabled	Enabled
1	1	Xtal1, Xtal2	Enabled	Enabled

Notes:

1. After CLK_EN switches, the clock outputs are disabled or enabled following a rising and falling input clock edge as show below.

Figure 1. CLK_EN Timing Diagram

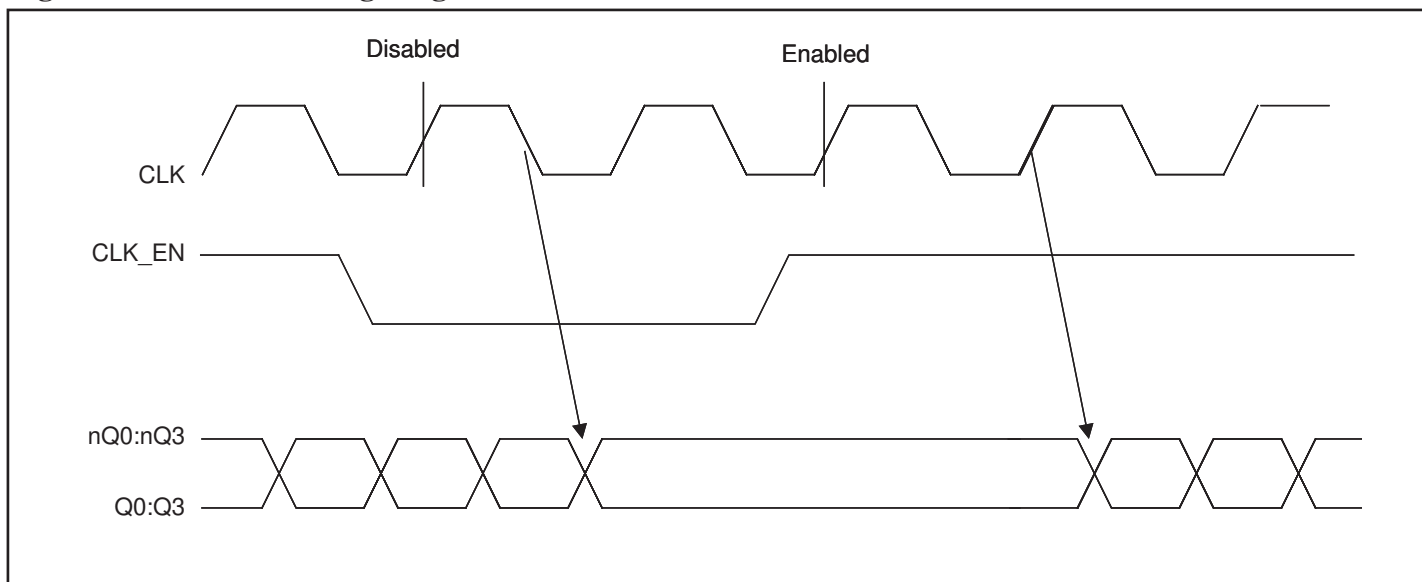

Clock Input Function Table

Inputs	Outputs	
CLK	Q0:Q3	nQ0:nQ3
0	LOW	HIGH
1	HIGH	LOW

Absolute Maximum Ratings

Symbol	Parameter	Conditions	Min.	Typ.	Max.	Units
V _{CC}	Supply voltage	Referenced to GND			4.6	V
V _{IN}	Input voltage	Referenced to GND	-0.5		V _{CC} +0.5V	
V _{OUT}	Output voltage	Referenced to GND	-0.5		V _{CC} +0.5V	
T _{STG}	Storage temperature		-65		150	°C

Notes:

1. Stresses above those listed under Absolute Maximum Ratings may cause permanent damage to the device. These ratings are stress specifications only and correct functional operation of the device at these or any other conditions above those listed in the operational sections of the specifications is not implied. Exposure to absolute maximum rating conditions for extended periods may affect product reliability.

Operating Conditions

Symbol	Parameter	Conditions	Min.	Typ.	Max.	Units
V _{CC}	Power Supply Voltage		3.0	3.3	3.6	V
T _A	Ambient Temperature		-40		85	°C
I _{EE}	Power Supply Current				60	mA

LVCMOS/LVTTL DC Characteristics ($T_A = -40^{\circ}\text{C}$ to 85°C , $V_{CC} = 3.0\text{V}$ to 3.6V unless otherwise stated below.)

Symbol	Parameter	Conditions	Min	Typ	Max	Units
V_{IH}	Input High Voltage		2		$V_{CC}+0.3$	V
V_{IL}	Input Low Voltage		-0.3		0.8	
I_{IH}	Input High Current	CLK, CLK_SEL	$V_{IN} = V_{CC} = 3.6\text{V}$		150	μA
		CLK_EN	$V_{IN} = V_{CC} = 3.6\text{V}$		5	
I_{IL}	Input Low Current	CLK, CLK_SEL	$V_{IN} = 0\text{V}, V_{CC} = 3.6\text{V}$	-5		
		CLK_EN	$V_{IN} = 0\text{V}, V_{CC} = 3.6\text{V}$	-150		

LVPECL DC Characteristics ($T_A = -40^{\circ}\text{C}$ to 85°C , $V_{CC} = 3.0\text{V}$ to 3.6V unless otherwise stated below.)

Symbol	Parameter	Conditions	Min.	Typ.	Max.	Units
V_{OH}	Output High Voltage ⁽¹⁾		$V_{CC}-1.4$		$V_{CC}-0.9$	V
V_{OL}	Output Low Voltage ⁽¹⁾		$V_{CC}-2.0$		$V_{CC}-1.7$	
V_{SWING}	Peak-to-peak Output Voltage Swing		0.6		1.0	

Notes:

1. Outputs terminated with 50Ω to $V_{CC}-2.0\text{V}$

Crystal Characteristics

Parameter	Min.	Typ.	Max.	Units
Mode of Oscillation	Fundamental			
Frequency Range	12		40	MHz
Equivalent Series Resistance (ESR)			70	Ω
Shunt Capacitance			7	pF

AC Characteristics ($T_A = -40^{\circ}\text{C}$ to 85°C , $V_{CC} = 3.0\text{V}$ to 3.6V)

Symbol	Parameter	Conditions	Min.	Typ.	Max.	Units
f_{max}	Output Frequency				500	MHz
t_{pd}	Propagation Delay ⁽¹⁾		1.0		1.5	ns
$T_{sk(o)}$	Output-to-output Skew ⁽²⁾				30	ps
$T_{sk(pp)}$	Part-to-part Skew ⁽³⁾				150	
t_r/t_f	Output Rise/Fall time	20% - 80%	100		400	
odc	Output duty cycle		48		52	%
Osc	Crystal Tolerance				1000	ppm

Notes:

1. Measured from the $V_{CC}/2$ of the input to the differential output crossing point
2. Defined as skew between outputs at the same supply voltage and with equal load condition. Measured at the outputs differential crossing point.
3. Defined as skew between outputs on different parts operating at the same supply voltage and with equal load condition. Measured at the outputs differential crossing point.
4. All parameters are measured at 500MHz unless noted otherwise

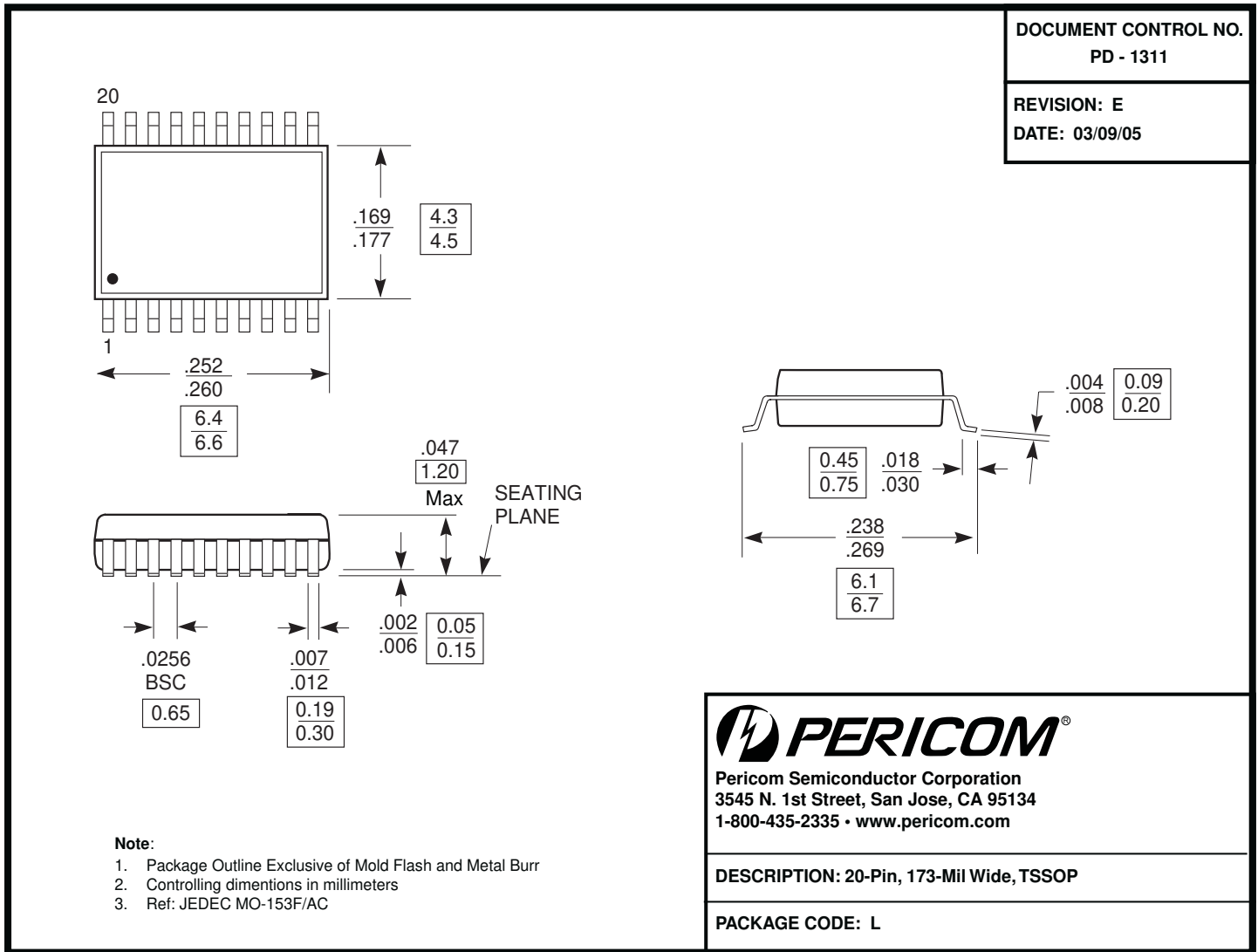
Packaging Mechanical: 20-Pin TSSOP (L)

Ordering Information

Ordering Code	Package Code	Package Description
PI6C48535-11LE	L	Pb-free & Green 20-pin 173-mil wide TSSOP

Notes:

- Thermal characteristics can be found on the company web site at www.pericom.com/packaging/