



Chipsmall Limited consists of a professional team with an average of over 10 year of expertise in the distribution of electronic components. Based in Hongkong, we have already established firm and mutual-benefit business relationships with customers from,Europe,America and south Asia,supplying obsolete and hard-to-find components to meet their specific needs.

With the principle of "Quality Parts,Customers Priority,Honest Operation,and Considerate Service",our business mainly focus on the distribution of electronic components. Line cards we deal with include Microchip,ALPS,ROHM,Xilinx,Pulse,ON,Everlight and Freescale. Main products comprise IC,Modules,Potentiometer,IC Socket,Relay,Connector.Our parts cover such applications as commercial,industrial, and automotives areas.

We are looking forward to setting up business relationship with you and hope to provide you with the best service and solution. Let us make a better world for our industry!



Contact us

Tel: +86-755-8981 8866 Fax: +86-755-8427 6832

Email & Skype: info@chipsmall.com Web: www.chipsmall.com

Address: A1208, Overseas Decoration Building, #122 Zhenhua RD., Futian, Shenzhen, China



Features

- Low skew outputs (250 ps)
- Packaged in 8-pin SOIC
- Low power CMOS technology
- Operating Voltages of 1.5 V to 3.3 V
- Output Enable pin tri-states outputs
- 3.6 V tolerant input clock
- Industrial temperature ranges

Description

The PI6C49X0204C is a low skew, single input to four output, clock buffer. Perfect for fanning out multiple clock outputs.

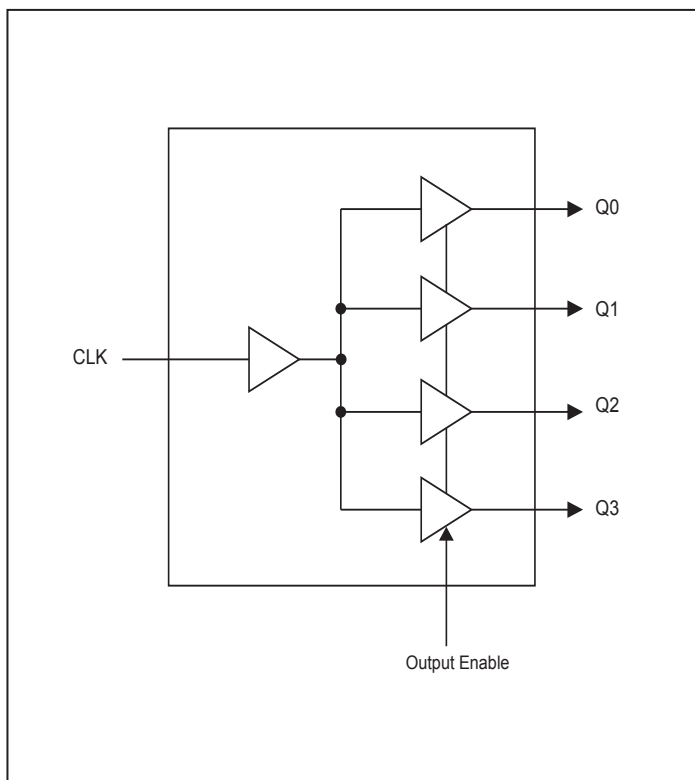
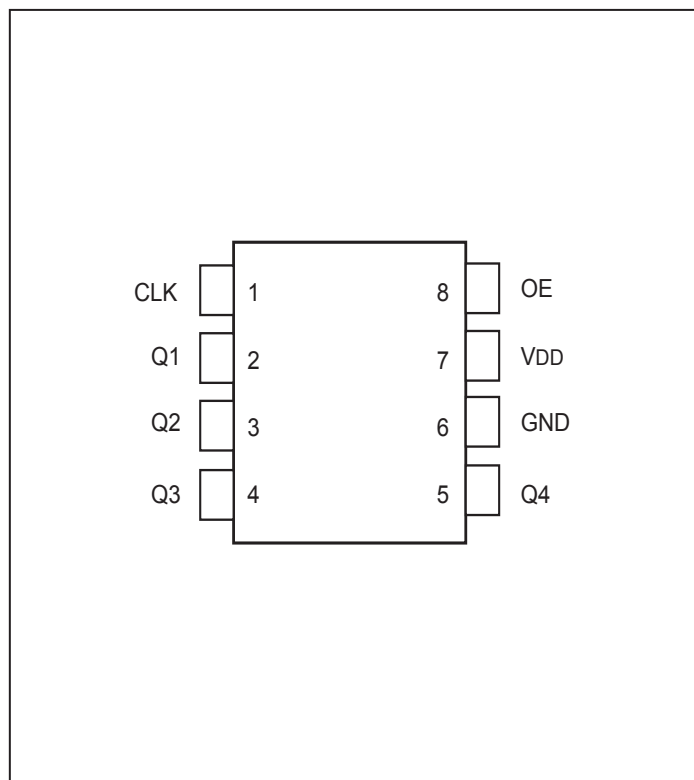
Block Diagram

Pin Assignment

Pin Descriptions

Pin#	Pin Name	Pin Type	Pin Description
1	CLK	Input	Clock Input. 3.3 V tolerant input.
2	Q1	Output	Clock Output 1.
3	Q2	Output	Clock Output 2.
4	Q3	Output	Clock Output 3.
5	Q4	Output	Clock Output 4.
6	GND	Power	Connect to ground.
7	VDD	Power	Connect to 1.5 V, 1.8V, 2.5V or 3.3V.
8	OE	Input	Output Enable. Tri-states outputs when low. Internal 125K Ω pull up resistor. Default on

External Components

A minimum number of external components are required for proper operation. A decoupling capacitor of 0.01 μ F should be connected between VDD on pin 7 and GND on pin 6, as close to the device as possible. A 33 Ω series terminating resistor may be used on each clock output if the trace is longer than 1 inch.

Maximum Ratings

Supply Voltage, VDD	4.6V
Output Enable and All Outputs	-0.5 V to VDD+0.5 V
CLK	-0.5 V to 3.6 V (VDD > 0V)
Ambient Operating Temperature (industrial)	-40 to +85 °C
Storage Temperature	-65 to +150°C
ESD Protection (HBM)	2000 V

Note:

Stresses above the ratings listed below can cause permanent damage to the PI6C49X0204C. Functional operation of the device at these or any other conditions above those indicated in the operational sections of the specifications is not implied.

Exposure to absolute maximum rating conditions for extended periods can affect product reliability. Electrical parameters are guaranteed only over the recommended operating temperature range.

Recommended Operation Conditions

Parameter	Min.	Typ.	Max.	Units
Ambient Operating Temperature (industrial)	-40		+85	°C
Power Supply Voltage (measured in respect to GND)	+1.425		+3.6	V

DC ELECTRICAL CHARACTERISTICS

VDD=1.5 V ±5%, Ambient temperature -40 to +85° C, unless stated otherwise

Symbol	Parameter	Conditions	Min.	Typ.	Max.	Units
VDD	Operating Voltage		1.425	1.5	1.575	V
V _{IH}	Input High Voltage	Note 1, CLK	1.17		3.6	V
V _{IL}	Input Low Voltage	Note 1, CLK			0.575	V
I _{IH}	Input High Current	Note 1, CLK			40	μA
I _{IL}	Input Low Current	Note 1, CLK			1	μA
I _{IH}	Input High Current	Note 1, OE			1	μA
I _{IL}	Input Low Current	Note 1, OE			40	μA
V _{OH}	Output High Voltage	I _{OH} = -6 mA	0.95			V
V _{OL}	Output Low Voltage	I _{OL} = 6 mA			0.45	V
IDD	Operating Supply Current	No load, 133 MHz			9	mA
Z _O	Nominal Output Impedance			20		Ω
C _{IN}	Input Capacitance	CLK, OE pin		5		pF
I _{OS}	Short Circuit Current			±12		mA

Notes: 1. Nominal switching threshold is VDD/2

VDD=1.8 V ±5%, Ambient temperature -40 to +85° C, unless stated otherwise

Symbol	Parameter	Conditions	Min.	Typ.	Max.	Units
VDD	Operating Voltage		1.71	1.8	1.89	V
V _{IH}	Input High Voltage	Note 1, CLK	1.7		3.6	V
V _{IL}	Input Low Voltage	Note 1, CLK			0.6	V
I _{IH}	Input High Current	Note 1, CLK			50	μA
I _{IL}	Input Low Current	Note 1, CLK			1	μA
I _{IH}	Input High Current	Note 1, OE			1	μA
I _{IL}	Input Low Current	Note 1, OE			50	μA
V _{OH}	Output High Voltage	I _{OH} = -8 mA	1.4			V
V _{OL}	Output Low Voltage	I _{OL} = 8 mA			0.4	V
IDD	Operating Supply Current	No load, 133 MHz			11	mA
Z _O	Nominal Output Impedance			20		Ω
C _{IN}	Input Capacitance	CLK, OE pin		5		pF
I _{OS}	Short Circuit Current			±20		mA

Notes: 1. Nominal switching threshold is VDD/2

VDD=2.5 V ±5%, Ambient temperature -40 to +85° C, unless stated otherwise

Symbol	Parameter	Conditions	Min.	Typ.	Max.	Units
VDD	Operating Voltage		2.375	2.5	2.625	V
V _{IH}	Input High Voltage	Note 1, CLK	1.7		3.6	V
V _{IL}	Input Low Voltage	Note 1, CLK			0.7	V
I _{IH}	Input High Current	Note 1, CLK			60	μA
I _{IL}	Input Low Current	Note 1, CLK			3	μA
I _{IH}	Input High Current	Note 1, OE			3	μA
I _{IL}	Input Low Current	Note 1, OE			60	μA
V _{OH}	Output High Voltage	I _{OH} = -8 mA	2			V
V _{OL}	Output Low Voltage	I _{OL} = 8 mA			0.4	V
IDD	Operating Supply Current	No load, 133 MHz			15	mA
Z _O	Nominal Output Impedance			20		Ω
C _{IN}	Input Capacitance	CLK, OE pin		5		pF
I _{OS}	Short Circuit Current			±50		mA

Notes: 1. Nominal switching threshold is VDD/2

VDD=3.3 V ±10%, Ambient temperature -40 to +85° C, unless stated otherwise

Symbol	Parameter	Conditions	Min.	Typ.	Max.	Units
VDD	Operating Voltage		3.0	3.3	3.6	V
V _{IH}	Input High Voltage	Note 1, CLK	2.1		3.6	V
V _{IL}	Input Low Voltage	Note 1, CLK			0.7	V
I _{IH}	Input High Current	Note 1, CLK			85	μA
I _{IL}	Input Low Current	Note 1, CLK			1	μA
I _{IH}	Input High Current	Note 1, OE			1	μA
I _{IL}	Input Low Current	Note 1, OE			85	μA
V _{OH}	Output High Voltage	I _{OH} = -8 mA	2.8			V
V _{OL}	Output Low Voltage	I _{OL} = 8 mA			0.2	V
IDD	Operating Supply Current	No load, 133 MHz			21	mA
Z _O	Nominal Output Impedance			20		Ω
C _{IN}	Input Capacitance	CLK, OE pin		5		pF
I _{OS}	Short Circuit Current			±50		mA

Notes: 1. Nominal switching threshold is VDD/2

AC ELECTRICAL CHARACTERISTICS

VDD=1.5 V ±5%, Ambient temperature -40 to +85° C, unless stated otherwise

Symbol	Parameter	Conditions	Min.	Typ.	Max.	Units
F _{OUT}	Output Frequency		0		166	MHz
t _{OR}	Output Rise Time	20% to 80%		1.0	1.5	ns
t _{OF}	Output Fall Time	20% to 80%		1.0	1.5	ns
T _{PD}	Propagation Delay (Note1)		2	3	5	ns
T _{SK}	Output to Output Skew (Note2)	Rising edges at VDD/2		0	±250	ps

AC ELECTRICAL CHARACTERISTICS

VDD=1.8 V ±5%, Ambient temperature -40 to +85° C, unless stated otherwise

Symbol	Parameter	Conditions	Min.	Typ.	Max.	Units
F _{OUT}	Output Frequency		0		166	MHz
t _{OR}	Output Rise Time	20% to 80%		1.0	1.5	ns
t _{OF}	Output Fall Time	20% to 80%		1.0	1.5	ns
T _{PD}	Propagation Delay (Note1)		1.3	2	4	ns
T _{SK}	Output to Output Skew (Note2)	Rising edges at VDD/2		0	±250	ps
J _{ADD}	Additive Jitter	@156.25MHz, 12k to 20MHz		0.1		ps

VDD=2.5 V ±5%, Ambient temperature -40 to +85° C, unless stated otherwise

Symbol	Parameter	Conditions	Min.	Typ.	Max.	Units
F _{OUT}	Output Frequency		0		200	MHz
t _{OR}	Output Rise Time	20% TO 80%		1.0	1.5	ns
t _{OF}	Output Fall Time	20% TO 80%		1.0	1.5	ns
T _{PD}	Propagation Delay (Note1)		0.8	1.5	3	ns
T _{SK}	Output to Output Skew (Note2)	Rising edges at VDD/2		0	±250	ps
J _{ADD}	Additive Jitter	@156.25MHz, 12k to 20MHz		0.05		ps

Notes:

1. With rail to rail input clock
2. Between any 2 outputs with equal loading.

VDD=3.3 V ±10%, Ambient temperature -40 to +85° C, unless stated otherwise

Symbol	Parameter	Conditions	Min.	Typ.	Max.	Units
F _{OUT}	Output Frequency		0		200	MHz
t _{OR}	Output Rise Time	20% TO 80%		1.0	1.5	ns
t _{OF}	Output Fall Time	20% TO 80%		1.0	1.5	ns
T _{PD}	Propagation Delay (Note1)		0.8	1.0	2.5	ns
T _{SK}	Output to Output Skew (Note2)	Rising edges at VDD/2		0	±250	ps
J _{ADD}	Additive Jitter	@156.25MHz, 12k to 20MHz		0.05		ps

Notes:

1. With rail to rail input clock
2. Between any 2 outputs with equal loading.

THERMAL CHARACTERISTICS

Symbol	Parameter	Typ.	Units
θ _{JA}	Thermal Resistance Junction to Ambient	157	°C/W
θ _{JC}	Thermal Resistance Junction to Case	42	°C/W

Phase Noise Plot

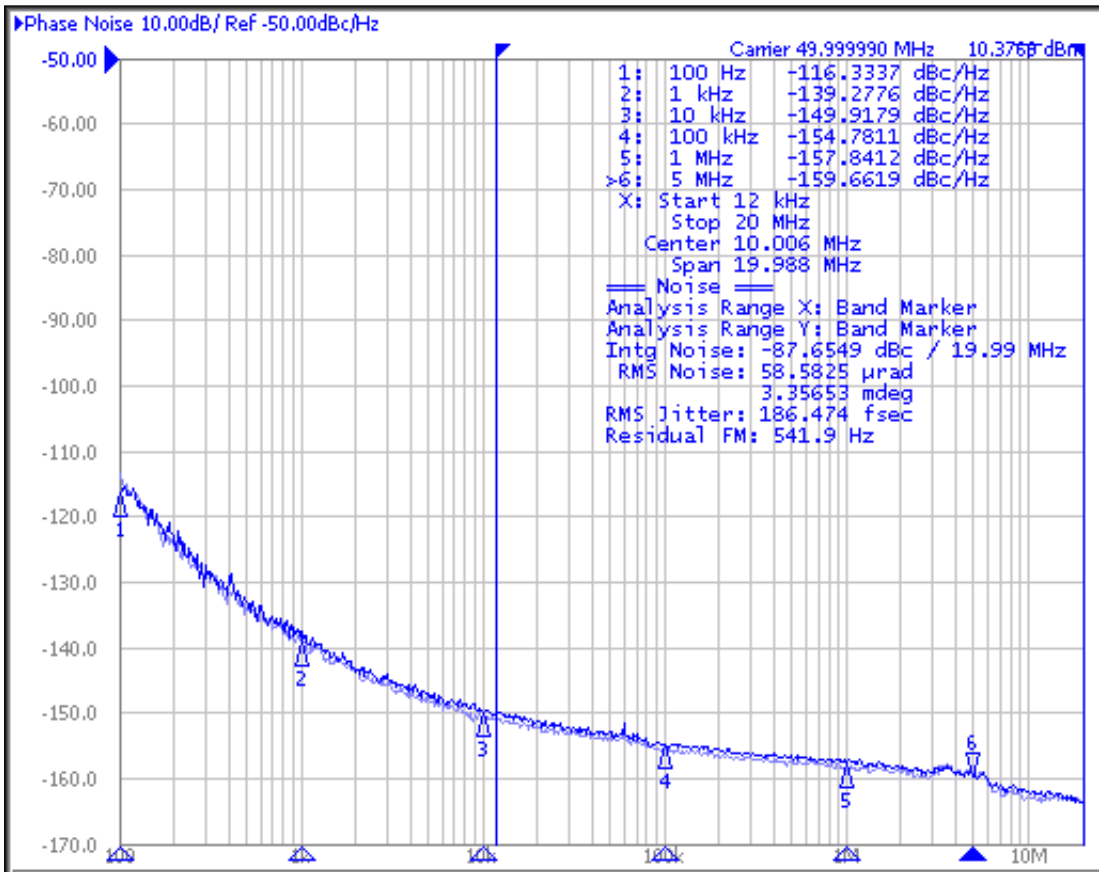

Application information

Suggest for Unused Inputs and Outputs

LVC MOS Input Control Pins

It is suggested to add pull-up=4.7k and pull-down=1k for LVC-MOS pins even though they have internal pull-up/down but with much higher value (>=50k) for higher design reliability.

Outputs

All unused outputs are suggested to be left open and not connected to any trace. This can lower the IC power consumption.

Power Decoupling & Routing

VDD Pin Decoupling

Each VDD pin must have a 0.1uF decoupling capacitor. For better decoupling, 1uF can be used. Locating the decoupling capacitor on the component side has better decoupling filter result as shown.

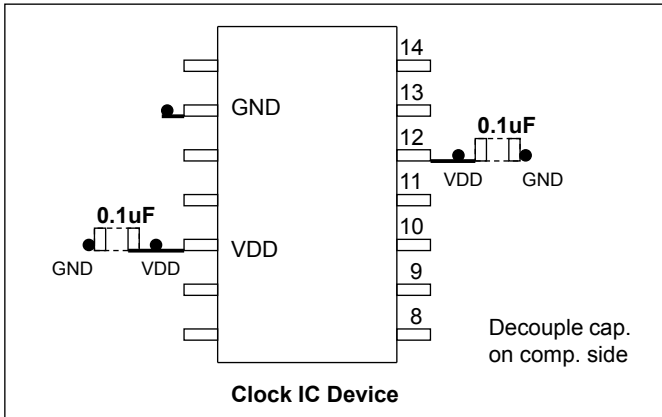

Placement of Decoupling caps

CMOS Clock Trace Routing

Please ensure that there is a sufficient keep-out area to the adjacent trace (>20mil.). In an example using a 125MHz XO driving a buffer IC, it is better to route the clock trace on the component side with a 33 ohm termination resistor.

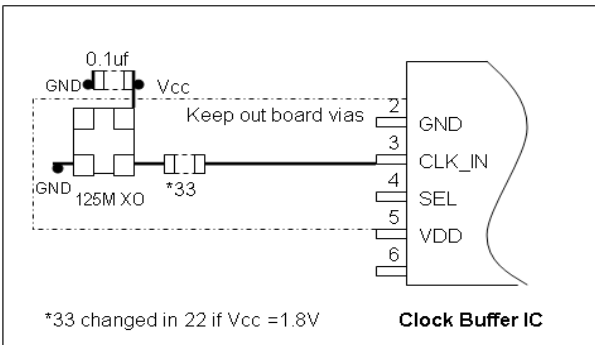

CMOS Output Termination

Popular CMOS Output Termination

The most popular CMOS termination is a serial resistor close to the output pin (<=200mil). It is simple and balances the drive strength. The resistor's value can be fine tuned for best performance during board bring-up based on VDDO voltage used.

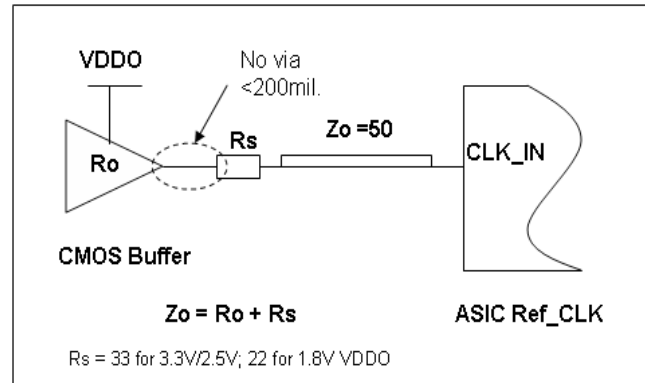

Combining Serial and Parallel Termination

Designers can also use a parallel termination for CMOS outputs. For example, a 50 ohm pull-down resistor can be used at the Rx side to reduce signal reflection, but it reduces the signals V_swing in half. This pull-down can be combined with a serial resistor to form a smaller clock voltage difference. The following diagram shows how to transition a 2.5V clock into 1.8V clock.

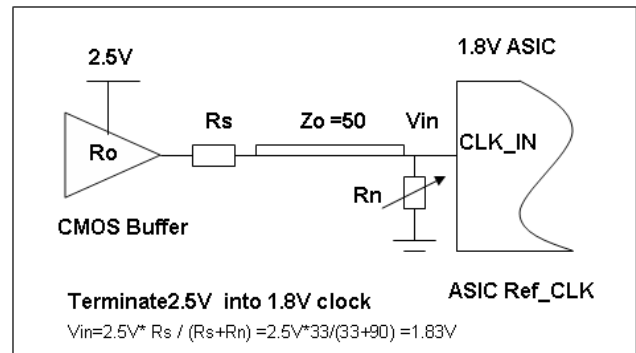

Rs = 33 ohm with Rn = 100 ohm, to transition 3.3V CMOS to 2.5V

Rs= 43 ohm with Rn =70 ohm to transition 3.3V CMOS to 1.8V

Clock Jitter Definitions

Total jitter= RJ + DJ

Random Jitter (RJ) is unpredictable and unbounded timing noise that can fit in a Gaussian math distribution in RMS. RJ test values are directly related with how long or how many test samples are available. Deterministic Jitter (DJ) is timing jitter that is predictable and periodic in fixed interference frequency. Total Jitter (TJ) is the combination of random jitter and deterministic jitter: $TJ = \sqrt{RJ^2 + DJ^2}$, where K is a factor based on total test sample count. JEDEC std. specifies digital clock TJ in 10k random samples.

Phase Jitter

Phase noise is short-term random noise attached on the clock carrier and it is a function of the clock offset from the carrier, for example dBc/Hz@10kHz which is phase noise power in 1-Hz normalized bandwidth vs. the carrier power @10kHz offset. Integration of phase noise in plot over a given frequency band yields RMS phase jitter, for example, to specify phase jitter ≤ 1 ps at 12k to 20MHz offset band as SONET standard specification.

Device Thermal Calculation

The JEDEC thermal model in a 4-layer PCB is shown below.

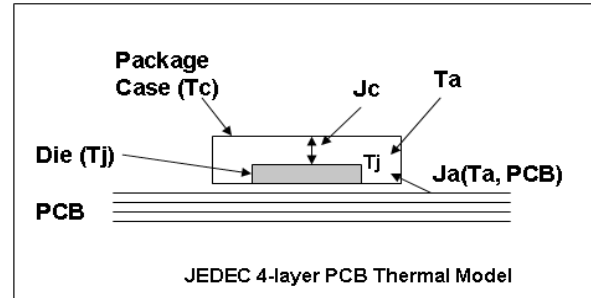

JEDEC IC Thermal Model

Important factors to influence device operating temperature are:

- 1) The power dissipation from the chip (P_{chip}) is after subtracting power dissipation from external loads. Generally it can be the no-load device I_{dd}
- 2) Package type and PCB stack-up structure, for example, 1oz 4 layer board. PCB with more layers and are thicker has better heat dissipation
- 3) Chassis air flow and cooling mechanism. More air flow M/s and adding heat sink on device can reduce device final die junction temperature T_j

The individual device thermal calculation formula:

$$T_j = T_a + P_{chip} \times J_a$$

$$T_c = T_j - P_{chip} \times J_c$$

J_a ___ Package thermal resistance from die to the ambient air in C/W unit; This data is provided in JEDEC model simulation. An air flow of 1m/s will reduce J_a (still air) by 20~30%

J_c ___ Package thermal resistance from die to the package case in C/W unit

T_j ___ Die junction temperature in C (industry limit <125C max.)

T_a ___ Ambient air temperature in C

T_c ___ Package case temperature in C

P_{chip} ___ IC actually consumes power through I_{ee}/GND current

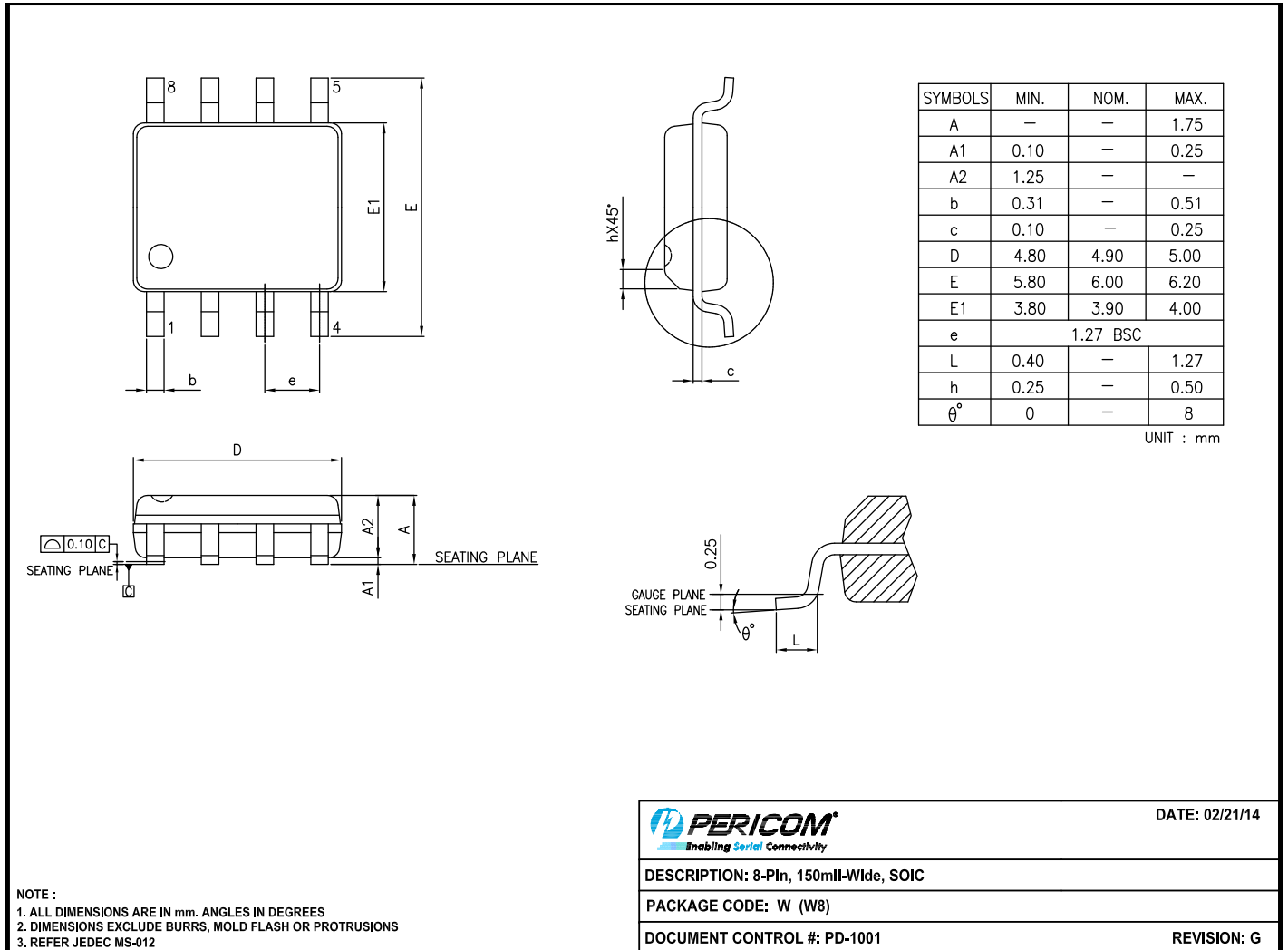

15-0103

Note:
 • For latest package info, please check: <http://www.pericom.com/products/packaging/mechanicals.php>

Ordering Information⁽¹⁻³⁾

Ordering Code	Package Code	Package Description
PI6C49X0204CWIE	W	8-pin, Pb-free & Green, SOIC
PI6C49X0204CWIEX	W	8-pin, Pb-free & Green, SOIC, Tape & Reel

Notes:

1. Thermal characteristics can be found on the company web site at www.pericom.com/packaging/
2. E = Pb-free and Green
3. Adding an X suffix = Tape/Reel