



Chipsmall Limited consists of a professional team with an average of over 10 year of expertise in the distribution of electronic components. Based in Hongkong, we have already established firm and mutual-benefit business relationships with customers from,Europe,America and south Asia,supplying obsolete and hard-to-find components to meet their specific needs.

With the principle of “Quality Parts,Customers Priority,Honest Operation,and Considerate Service”,our business mainly focus on the distribution of electronic components. Line cards we deal with include Microchip,ALPS,ROHM,Xilinx,Pulse,ON,Everlight and Freescale. Main products comprise IC,Modules,Potentiometer,IC Socket,Relay,Connector.Our parts cover such applications as commercial,industrial, and automotives areas.

We are looking forward to setting up business relationship with you and hope to provide you with the best service and solution. Let us make a better world for our industry!



Contact us

Tel: +86-755-8981 8866 Fax: +86-755-8427 6832

Email & Skype: info@chipsmall.com Web: www.chipsmall.com

Address: A1208, Overseas Decoration Building, #122 Zhenhua RD., Futian, Shenzhen, China



Ultra Low Power 4-Output PCIe Clock Generator With On-chip Termination

Features

- 1.5V supply voltage
- Crystal/CMOS input: 25 MHz
- 4 differential low power HCSL outputs with on-chip termination
- Individual output enable
- Reference CMOS output
- Programmable Slew rate and output amplitude for each output
- Differential outputs blocked until PLL is locked
- Selectable 0%, -0.25% or -0.5% spread on differential outputs
- Strapping pins or SMBus for configuration;
- 3.3V tolerant SMBus interface support
- Very low jitter outputs
 - Differential cycle-to-cycle jitter <50ps
 - Differential output-to-output skew <50ps
 - PCIe Gen1/Gen2/Gen3/ Gen4 compliant
 - CMOS REFOUT phase jitter is < 1.5ps RMS
- Packaging (Pb-free & Green): 32-lead 5x5mm TQFN

Description

The PI6CG15401 is an 4-output ultra low power PCIe Gen1/ Gen2/Gen3/ Gen4 clock generator. It uses 25MHz crystal or CMOS reference as an input to generate the 100MHz low power differential HCSL outputs with on-chip terminations. The on-chip termination can save 16 external resistors and make layout easier. An additional buffered reference output is provided to serve as a low noise reference for other circuitry.

It uses Diodes proprietary PLL design to achieve very low jitter that meets PCIe Gen1/Gen2/Gen3 requirements. It also provides various options such as different slew rate and amplitude through strapping pins or SMBUS so that users can configure the device easily to get the optimized performance for their individual boards. The device also supports selectable spread-spectrum options to reduce EMI for various applications.

Pin Configuration

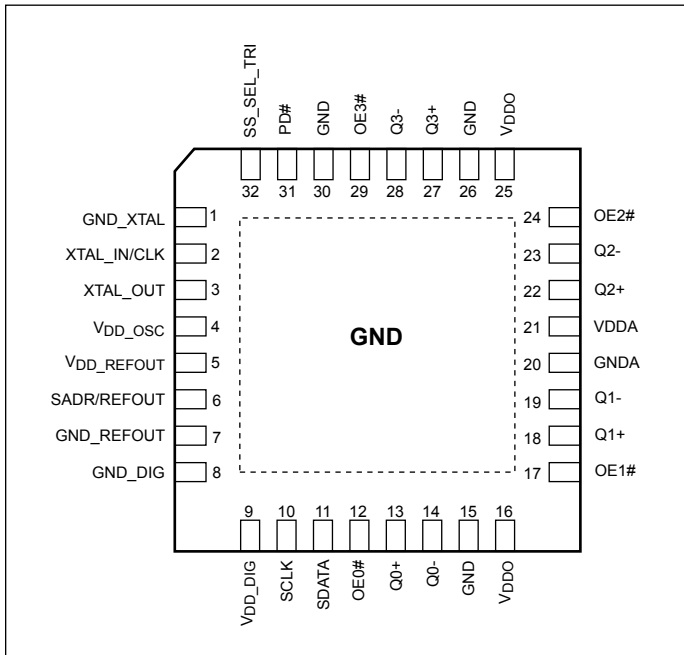

Block Diagram

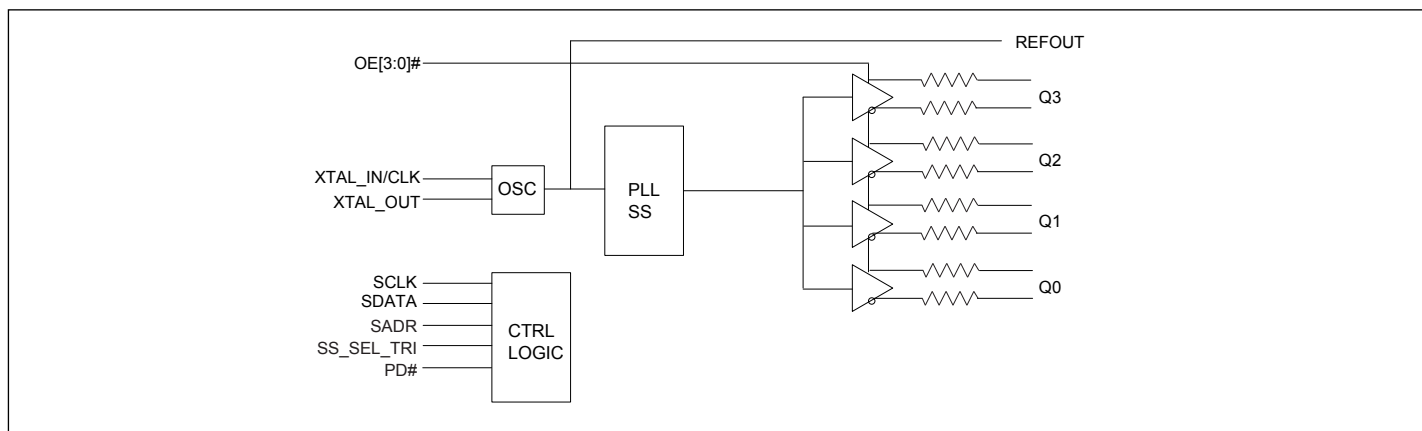

Pin Description

| Pin # | Pin Name | Type | | Description |
|------------|-------------------------|------------------|------|---|
| 1 | GND_XTAL | Power | | Ground for oscillator circuit |
| 2 | XTAL_IN/CLK | Input | | Crystal input or CMOS reference input |
| 3 | XTAL_OUT | Output | | Crystal output |
| 4 | V _{DD} _OSC | Power | | Power supply for oscillator circuitry, nominal 1.5V |
| 5 | V _{DD} _REFOUT | Power | | Power supply for buffered CMOS output |
| 6 | SADR/REFOUT | Input/ Output | CMOS | Latch to select SMBus Address or 1.5V LVCMOS REFOUT. This pin has internal pull-down. |
| 7 | GND_REFOUT | Power | | Ground for REFOUT |
| 8 | GND_DIG | Power | | Ground for digital circuitry |
| 9 | V _{DD} _DIG | Power | | Power supply for digital circuitry, nominal 1.5V |
| 10 | SCLK | Input | CMOS | SMBUS clock input, 3.3V tolerant |
| 11 | SDATA | Input/ Output | CMOS | SMBUS Data line, 3.3V tolerant |
| 12 | OE0# | Input | CMOS | Active low input for enabling Q0 pair. This pin has an internal pull-down. 1 =disable outputs, 0 = enable outputs |
| 13 | Q0+ | Output | HCSL | Differential true clock output |
| 14 | Q0- | Output | HCSL | Differential complementary clock output |
| 15, 26, 30 | GND | Power | | Ground |
| 16, 25 | V _{DDO} | Power | | Power supply for differential outputs |
| 17 | OE1# | Input | CMOS | Active low input for enabling Q1 pair. This pin has an internal pull-down. 1 =disable outputs, 0 = enable outputs |
| 18 | Q1+ | Output | HCSL | Differential true clock output |
| 19 | Q1- | Output | HCSL | Differential complementary clock output |
| 20 | GNDA | Power | | Ground for analog circuitry |

Pin Description (cont.)

| Pin # | Pin Name | Type | | Description |
|-------|------------------|--------|-----------|---|
| 21 | V _{DDA} | Power | | Power supply for analog circuitry |
| 22 | Q2+ | Output | HCSL | Differential true clock output |
| 23 | Q2- | Output | HCSL | Differential complementary clock output |
| 24 | OE2# | Input | CMOS | Active low input for enabling Q2 pair. This pin has an internal pull-down. 1 =disable outputs, 0 = enable outputs |
| 27 | Q3+ | Output | HCSL | Differential true clock output |
| 28 | Q3- | Output | HCSL | Differential complementary clock output |
| 29 | OE3# | Input | CMOS | Active low input for enabling Q3 pair. This pin has an internal pull-down. 1 =disable outputs, 0 = enable outputs |
| 31 | PD# | Input | CMOS | Input notifies device to sample latched inputs and start up on first high assertion. Low enters Power Down Mode, subsequent high assertions exit Power Down Mode. This pin has internal pull-up resistor. |
| 32 | SS_SEL_TRI | Input | Tri-level | Latched select input to select spread spectrum amount at initial power up 1 = -0.5% spread, M = -0.25%, 0 = Spread Off |

SMBus Address Selection Table

| | SADR | Address | +Read/Write Bit |
|---|------|---------|-----------------|
| State of SADR on first application of PD# | 0 | 1101000 | X |
| | 1 | 1101010 | X |

Power Management Table

| PD# | SMBus OE bit | OEn# | Qn+ | Qn- | REFOUT |
|-----|--------------|------|---------|---------|---------|
| 0 | X | X | Low | Low | HiZ |
| 1 | 1 | 0 | Running | Running | Running |
| 1 | 1 | 1 | Low | Low | Low |
| 1 | 0 | X | Low | Low | Low |

Maximum Ratings

(Above which useful life may be impaired. For user guidelines, not tested.)

| | |
|--|--|
| Storage Temperature..... | -65°C to +150°C |
| Junction Temperature..... | up to +125°C |
| Supply Voltage to Ground Potential, V_{DDxx} | -0.5V to +2.0V |
| Input Voltage | -0.5V to $V_{DD}+0.5V$, not exceed 2.0V |
| SMBus, Input High Voltage | 3.3V |
| ESD Protection (HBM) | 2000 V |

Note: Stresses greater than those listed under MAXIMUM RATINGS may cause permanent damage to the device. This is a stress rating only and functional operation of the device at these or any other conditions above those indicated in the operational sections of this specification is not implied. Exposure to absolute maximum rating conditions for extended periods may affect reliability.

Operating Conditions

Temperature = T_A ; Supply voltages per normal operation conditions; See test circuits for the load conditions

| Symbol | Parameters | Conditions | Min. | Typ. | Max. | Units |
|---|---|---|-------|------|-------|-------|
| $V_{DD}, V_{DDA}, V_{DD_OSC}, V_{DD_REFOUT}, V_{DD_DIG}$ | Power Supply Voltage | | 1.425 | 1.5 | 1.575 | V |
| V_{DDO} | Output Power Supply Voltage | | 1.425 | 1.5 | 1.575 | V |
| I_{DDA} | Analog Power Supply Current | All outputs active @100MHz | | 6 | 9 | mA |
| I_{DD} | Power Supply Current | All V_{DD} , except V_{DDA} and V_{DDO} , All outputs active @100MHz | | 21 | 27 | mA |
| I_{DDO} | Power Supply Current for Outputs | All outputs active @100MHz | | 21 | 25 | mA |
| I_{DDA_WL} | Analog Power Supply Wake-on-LAN ¹ Current | Q outputs off, REF output running | | 0.4 | 1 | mA |
| I_{DD_WL} | Power Supply Wake-on-LAN ¹ Current | All V_{DD} , except V_{DDA} and V_{DDO} , Q outputs off, REF output running | | 4.5 | 6.5 | mA |
| I_{DDO_WL} | Power Supply Wake-on-LAN ¹ Current for Outputs | Q outputs off, REF output running | | 0.04 | 0.1 | mA |
| I_{DDA_PD} | Analog Power Supply Power Down ² Current | All outputs off | | 0.4 | 1 | mA |
| I_{DD_PD} | Power Supply Power Down ² Current | All outputs off | | 0.4 | 1 | mA |
| I_{DDO_PD} | Power Supply Current Power Down ² for Outputs | All outputs off | | | 0.1 | mA |
| T_A | Ambient Temperature | Industrial grade | -40 | | 85 | °C |

Note:

1. Wake-on-LAN mode: PD# = '0' Byte 3, bit 5 = '1'
2. Power down mode: PD# = '0' Byte 3, bit 5 = '0'

Input Electrical Characteristics

| Symbol | Parameters | Conditions | Min. | Typ. | Max. | Units |
|-------------------|---|------------|------|------|------|-------|
| R _{pu} | Internal pull up resistance | | | 120 | | KΩ |
| R _{dn} | Internal pull down resistance | | | 120 | | KΩ |
| C _{XTAL} | Internal capacitance on X_IN and X_OUT pins | | | 5 | | pF |
| L _{PIN} | Pin inductance | | | | 7 | nH |

Crystal Characteristic

| Parameters | Description | Min. | Typ | Max. | Units |
|--------------------|------------------------------|-------------|-----|------|-------|
| OSCmode | Mode of Oscillation | Fundamental | | | |
| FREQ | Frequency | | 25 | | MHz |
| ESR ¹ | Equivalent Series Resistance | | | 50 | Ω |
| C _{load} | Load Capacitance | | 8 | | pF |
| C _{shunt} | Shunt Capacitance | | | 7 | pF |
| | Drive Level | | | 300 | uW |

Note:

1. ESR value is dependent upon frequency of oscillation

SMBus Electrical Characteristics

Temperature = T_A; Supply voltages per normal operation conditions; See test circuits for the load conditions

| Symbol | Parameters | Conditions | Min. | Typ. | Max. | Units |
|----------------------|---------------------------|--|----------------------------|------|------|-------|
| V _{DDSMB} | Nominal bus voltage | | 1.425 | | 3.3 | V |
| V _{IHSMB} | SMBus Input High Voltage | SMBus, V _{DDSMB} = 3.3V | 2.1 | | 3.3 | V |
| | | SMBus, V _{DDSMB} < 3.3V | 0.65 V _{DDSMB} | | | |
| V _{ILSMB} | SMBus Input Low Voltage | SMBus, V _{DDSMB} = 3.3V | | | 0.6 | V |
| | | SMBus, V _{DDSMB} < 3.3V | | | 0.6 | |
| I _{SMBSINK} | SMBus sink current | SMBus, at V _{OLSMB} | 4 | | | mA |
| V _{OLSMB} | SMBus Output Low Voltage | SMBus, at I _{SMBSINK} | | | 0.4 | V |
| f _{MAXSMB} | SMBus operating frequency | Maximum frequency | | | 400 | kHz |
| t _{RMSB} | SMBus rise time | (Max V _{IL} - 0.15) to (Min V _{IH} + 0.15) | | | 1000 | ns |
| t _{FMSB} | SMBus fall time | (Min V _{IH} + 0.15) to (Max V _{IL} - 0.15) | | | 300 | ns |

Spread Spectrum Characteristic

Temperature = T_A; Supply voltages per normal operation conditions; See test circuits for the load conditions

| Symbol | Parameters | Conditions | Min. | Typ. | Max. | Units |
|------------------|-------------------------|-----------------------|------|------|------|-------|
| f _{MOD} | SS Modulation Frequency | Triangular modulation | 30 | 31.6 | 33 | kHz |

LVC MOS DC Electrical Characteristics

Temperature = T_A ; Supply voltages per normal operation conditions; See test circuits for the load conditions

| Symbol | Parameters | Conditions | Min. | Typ. | Max. | Units |
|-----------|-----------------------|--|-------------------|-------------|------------------|----------|
| V_{IH} | Input High Voltage | Single-ended inputs, except SMBus | 0.75 V_{DD} | | V_{DD} +0.3 | V |
| V_{IM} | Input Mid Voltage | SS_SEL_TRI | $0.4V_{DD}$ | $0.5V_{DD}$ | $0.6V_{DD}$ | V |
| V_{IL} | Input Low Voltage | Single-ended inputs, except SMBus | -0.3 | | 0.25 V_{DD} | V |
| I_{IH} | Input High Current | Single-ended inputs, $V_{IN} = V_{DD}$ | | | 20 | μA |
| I_{IL} | Input Low Current | Single-ended inputs, $V_{IN} = 0V$ | -20 | | | μA |
| I_{IH} | Input High Current | Single-ended inputs with pull up / pull down resistor, $V_{IN} = V_{DD}$ | | | 220 | μA |
| I_{IL} | Input Low Current | Single-ended inputs with pull up / pull down resistor, $V_{IN} = 0V$ | -220 | | | μA |
| V_{OH} | Output High Voltage | REFOUT, except SMBus; $I_{OH} = -2mA$ | V_{DD} -0.45 | | | V |
| V_{OL} | Output Low Voltage | REFOUT, except SMBus; $I_{OH} = 2mA$ | | | 0.45 | V |
| R_{OUT} | CMOS Output impedance | | | 20 | | Ω |
| C_{IN} | Input Capacitance | | 1.5 | | 5 | pF |

LVC MOS AC Characteristics

Temperature = T_A ; Supply voltages per normal operation conditions; See test circuits for the load conditions

| Symbol | Parameters | Conditions | Min. | Typ. | Max. | Units |
|--------------|--|---|------|------|------|--------|
| f_{INPUT} | Input Frequency | XTAL_IN/CLK | 23 | 25 | 27 | MHz |
| t_{RIN} | Input rise time | Single-ended inputs | | | 5 | ns |
| t_{FIN} | Input fall time | Single-ended inputs | | | 5 | ns |
| t_{STAB} | Clock stabilization | From Power-Up and after input clock stabilization or de-assertion of PD# to 1st clock | | | 1.8 | ms |
| t_{OELAT} | Output enable latency | Q start after OE# assertion Q stop after OE# deassertion | 1 | | 3 | clocks |
| t_{PDLAT} | PD# de-assertion | Differential outputs enable after PD# de-assertion | | 20 | 300 | us |
| t_{PERIOD} | REFOUT clock period | REFOUT, assume input is at 25MHz | | 40 | | ns |
| f_{ACC} | REFOUT frequency accuracy ¹ | REFOUT, long term accuracy to input | | 0 | | ppm |
| t_{SLEW} | REFOUT slew rate ¹ | Byte 3 = 1F, 20% to 80% of V_{DDREF} | 0.3 | 0.7 | 1.1 | V/ns |
| | | Byte 3 = 5F, 20% to 80% of V_{DDREF} | 0.5 | 1.0 | 1.6 | V/ns |
| | | Byte 3 = 9F, 20% to 80% of V_{DDREF} | 0.6 | 1.3 | 1.9 | V/ns |
| | | Byte 3 = DF, 20% to 80% of V_{DDREF} | 0.84 | 1.4 | 2.0 | V/ns |
| t_{DC} | REFOUT Duty Cycle ¹ | $V_T = V_{DD} / 2$ V, driven by a Xtal | 45 | 50 | 55 | % |

LVCMOS AC Characteristics (Cont.)

| Symbol | Parameters | Condition | Min. | Typ. | Max. | Units |
|--------------------|------------------------------|--|------|------|------|-------|
| t _{DCDIS} | REFOUT Duty Cycle Distortion | V _T = V _{DD} / 2 V, driven by an external source | 0 | 2 | 4 | % |
| t _{JITCC} | REFOUT cycle-cycle jitter | V _T = V _{DD} / 2 V, driven by a Xtal | | 51 | 250 | ps |
| t _{JITPH} | REFOUT phase jitter | 12kHz to 5MHz, RMS, driven by a Xtal | | 1 | 3 | ps |
| t _{JITN} | Noise floor | 1kHz offset, driven by a Xtal | | -126 | -105 | dBc |
| | | 10kHz offset to Nyquist, driven by a Xtal | | -140 | -110 | dBc |

Note:

1. Guaranteed by design and characterization, not 100% tested in production

HCSL Output Characteristics

 Temperature = T_A; Supply voltages per normal operation conditions; See test circuits for the load conditions

| Symbol | Parameters | Condition | Min. | Typ. | Max. | Units |
|---------------------|---|---|------|------|------|-------|
| V _{OH} | Output Voltage High ¹ | Statistical measurement on single-ended signal using oscilloscope math function | 600 | 750 | 900 | mV |
| V _{OL} | Output Voltage Low ¹ | | -150 | | 150 | mV |
| V _{OMAX} | Output Voltage Maximum ¹ | Measurement on single ended signal using absolute value | | 760 | 1150 | mV |
| V _{OMIN} | Output Voltage Minimum ¹ | | -300 | 20 | | mV |
| V _{OSWING} | Output Swing Voltage ^{1,2,3} | Scope averaging off | 300 | 1450 | | mV |
| V _{OC} | Output Cross Voltage ^{1,2,4} | | 250 | 400 | 550 | mV |
| DV _{OC} | V _{OC} Magnitude Change ^{1,2,5} | | | 14 | 140 | mV |

Note:

1. At default SMBUS amplitude settings

2. Guaranteed by design and characterization, not 100% tested in production

3. Measured from differential waveform

4. This one is defined as voltage where Q+ = Q- measured on a component test board and only applied to the differential rising edge

 5. The total variation of all V_{cross} measurements in any particular system. This is a subset of V_{cross_min/max} allowed.

HCSL Output AC Characteristics

 Temperature = T_A; Supply voltages per normal operation conditions; See test circuits for the load conditions

| Symbol | Parameters | Condition | Min. | Typ. | Max. | Units |
|----------------------|--------------------------------------|------------------------------------|------|------|------|-------|
| f _{OUT} | Output Frequency | | | 100 | | MHz |
| t _{RF} | Slew rate ^{1,2,3} | Scope averaging on fast setting | 1.2 | 2.4 | 3.6 | V/ns |
| | | Scope averaging on slow setting | 0.8 | 1.7 | 3.0 | V/ns |
| D _{tRF} | Slew rate matching ^{1,2,4} | Scope averaging on | | 3 | 20 | % |
| t _{DC} | Duty Cycle ^{1,2} | Measured differentially, PLL Mode | 45 | 50 | 55 | % |
| t _{SKEW} | Output Skew ^{1,2} | Averaging on, V _T = 50% | | 34 | 50 | ps |
| t _{j-c-c} | Cycle to cycle jitter ^{1,2} | | | 15 | 50 | ps |
| t _{STARTUP} | Start up time | | | | 10 | ms |
| t _{LOCK} | PLL lock time | | | | 20 | ms |

HC SL Output AC Characteristics (continued)

| Symbol | Parameters | Condition | Min. | Typ. | Max. | Units |
|---------------------|--|---|------|------|------|-------|
| t _{JPHASE} | Integrated phase jitter (RMS) 1,5,6 | PCIe Gen 1 | 27 | 40 | 86 | ps |
| | | PCIe Gen 2 Low Band, 10kHz < f < 1.5MHz | 1.0 | 1.3 | 3.0 | ps |
| | | PCIe Gen 2 High Band, 1.5MHz < f < Nyquist (50MHz) | 1.9 | 2.2 | 3.1 | ps |
| | | PCIe Gen 3 Common Clock Architecture (PLL BW of 2-4 or 2-5MHz, CDR =10MHz) | 0.4 | 0.6 | 1.0 | ps |
| | | PCIe Gen 3 Separate Reference No Spread (PLL BW of 2-4 or 2-5MHz, CDR =10MHz) | 0.4 | 0.7 | 0.7 | ps |
| | | PCIe Gen 4 (PLL BW of 2-4 or 2-5MHz, CDR =10MHz) | 0.3 | 0.4 | 0.5 | ps |

Note:

1. Guaranteed by design and characterization, not 100% tested in production
2. Measured from differential waveform
3. Slew rate is measured through the V_{swing} voltage range centered around differential 0V, within +/-150mV window
4. Slew rate matching is measured using a +/-75mV window centered at differential zero
5. See <http://www.pcisig.com> for complete specs
6. Sample size of at least 100k cycles. This can be extrapolated to 108ps pk-pk @ 1M cycles for a BER of 10⁻¹²

Differential Output Clock Periods - Spread Spectrum Disabled ^{1, 2}

| Center Freq. MHz | Measurement Window | | | | | | | Units |
|------------------|------------------------|---------------------------|-------------------------|----------------------|-------------------------|---------------------------|------------------------|-------|
| | 1 clock | 1 us | 0.1 s | 0.1 s | 0.1 s | 1 us | 1 clock | |
| | -c2c jitter AbsPer Min | - SSC Short-term Avg. Min | -ppm Long-term Avg. min | 0 ppm Period Nominal | +ppm Long-term Avg. max | + SSC Short-term Avg. Max | -c2c jitter AbsPer Max | |
| 100.00 | 9.94900 | | 9.99900 | 10.00000 | 10.00100 | | 10.05100 | ns |

Differential Output Clock Periods - Spread Spectrum Enabled ^{1, 2}

| Center Freq. MHz | Measurement Window | | | | | | | Units |
|------------------|------------------------|---------------------------|-------------------------|----------------------|-------------------------|---------------------------|------------------------|-------|
| | 1 clock | 1 us | 0.1 s | 0.1 s | 0.1 s | 1 us | 1 clock | |
| | -c2c jitter AbsPer Min | - SSC Short-term Avg. Min | -ppm Long-term Avg. min | 0 ppm Period Nominal | +ppm Long-term Avg. max | + SSC Short-term Avg. Max | -c2c jitter AbsPer Max | |
| 99.75 | 9.94906 | 9.99906 | 10.02406 | 10.02506 | 10.02607 | 10.05107 | 10.10107 | ns |

Note:

1. Guaranteed by design and characterization, not 100% tested in production
2. All long term accuracy and clock period specifications are guaranteed assuming REF is trimmed to 25.00MHz

SMBus Serial Data Interface

PI6CG15401 is a slave only device that supports block read and block write protocol using a single 7-bit address and read/write bit as shown below.

Read and write block transfers can be stopped after any complete byte transfer.

Address Assignment

| A6 | A5 | A4 | A3 | A2 | A1 | A0 | R/W |
|----|----|----|----|----|------|----|-----|
| 1 | 1 | 0 | 1 | 0 | SADR | 0 | 1/0 |

Note: SMBus address is latched on SADR pin

How to Write

| 1 bit | 7 bits | 1 bit | 1 bit | 8 bits | 1 bit | 8 bits | 1 bit | 8 bits | 1 bit | | 8 bits | 1 bit | 1 bit |
|-----------|--------|-------|-------|-----------------------------|-------|---------------------|-------|-------------------------|-------|-------|-------------------|-------|----------|
| Start bit | Add. | W(0) | Ack | Beginning Byte location = N | Ack | Data Byte count = X | Ack | Beginning Data Byte (N) | Ack | | Data Byte (N+X-1) | Ack | Stop bit |

How to Read

| 1 bit | 7 bits | 1 bit | 1 bit | 8 bits | 1 bit | 1 bit | 7 bits | 1 bit | 1 bit | 8 bits | 1 bit | 8 bits | 1 bit |
|-----------|---------|-------|-------|-----------------------------|-------|------------------|---------|-------|-------|---------------------|-------|-------------------------|-------|
| Start bit | Address | W(0) | Ack | Beginning Byte location = N | Ack | Repeat Start bit | Address | R(1) | Ack | Data Byte count = X | Ack | Beginning Data Byte (N) | Ack |

| | 8 bits | 1 bit | 1 bit |
|-------|-------------------|-------|----------|
| | Data Byte (N+X-1) | NAck | Stop bit |

Byte 0: Output Enable Register ¹

| Bit | Control Function | Description | Type | Power Up Condition | 0 | 1 |
|-----|------------------|------------------|------|--------------------|---------|---------|
| 7 | Reserved | | | 1 | | |
| 6 | Reserved | | | 1 | | |
| 5 | Reserved | | | 1 | | |
| 4 | Reserved | | | 1 | | |
| 3 | Q3_OE | Q3 output enable | RW | 1 | Low/Low | Enabled |
| 2 | Q2_OE | Q2 output enable | RW | 1 | Low/Low | Enabled |
| 1 | Q1_OE | Q1 output enable | RW | 1 | Low/Low | Enabled |
| 0 | Q0_OE | Q0 output enable | RW | 1 | Low/Low | Enabled |

Note:

1. A low on these bits will override the OE# pins and force the differential outputs to Low/Low states

Byte 1: SS Readback and Control Register

| Bit | Control Function | Description | Type | Power Up Condition | 0 | 1 |
|-----|------------------|---------------------------|-----------------|--------------------|---|-------------------------------------|
| 7 | SSENRB1 | SS Enable Readback Bit1 | R | Latch | '00' for SS_SEL_TRI = '0', '01' for SS_SEL_TRI = 'M', '11' for SS_SEL_TRI = 'I' | |
| 6 | SSENRB0 | SS Enable Readback Bit0 | R | Latch | | |
| 5 | SSEN_SWCTR | Enable SW control of SS | RW | 0 | Values in B1[7:6] control SS amount | Values in B1[4:3] control SS amount |
| 4 | SSENSW1 | SS enable SW control Bit1 | RW ¹ | 0 | '00' = SS off, '01' = -0.25% SS, '10' = Reserved, '11' = -0.5% SS | |
| 3 | SSENSW0 | SS enable SW control Bit0 | RW ¹ | 0 | | |
| 2 | Reserved | | | 1 | | |
| 1 | Amplitude1 | Control output amplitude | RW | 1 | '00' = 0.55V, '01' = 0.65V, '10' = 0.7V, '11' = 0.8V | |
| 0 | Amplitude0 | | RW | 0 | | |

Note:

1. B1[5] must be set to a 1 for these bits to have any effect on the part.

Byte 2: Differential Output Slew Rate Control Register

| Bit | Control Function | Description | Type | Power Up Condition | 0 | 1 |
|-----|------------------|-------------------------|------|--------------------|--------------|--------------|
| 7 | Reserved | | | 1 | | |
| 6 | Reserved | | | 1 | | |
| 5 | Reserved | | | 1 | | |
| 4 | Reserved | | | 1 | | |
| 3 | SLEWRATECTR_Q3 | Control slew rate of Q3 | RW | 1 | Slow setting | Fast setting |
| 2 | SLEWRATECTR_Q2 | Control slew rate of Q2 | RW | 1 | Slow setting | Fast setting |
| 1 | SLEWRATECTR_Q1 | Control slew rate of Q1 | RW | 1 | Slow setting | Fast setting |
| 0 | SLEWRATECTR_Q0 | Control slew rate of Q0 | RW | 1 | Slow setting | Fast setting |

Byte 3: REF Control Register

| Bit | Control Function | Description | Type | Power Up Condition | 0 | 1 |
|-----|------------------|----------------------------|------|--------------------|----------------------------|---------------|
| 7 | REFSLEWRATE | Slew rate control for REF | RW | 0 | '00' = Slowest '01' = Slow | |
| 6 | | | RW | 1 | '10' = Fast, '11' = Faster | |
| 5 | REF_PDSTATE | Wake-on-Lan enable for REF | RW | 0 | REF = 'Low' | REF = running |
| 4 | REF_OE | Output enable for REF | RW | 1 | REF = "Low" | REF = running |
| 3 | Reserved | | | 1 | | |
| 2 | Reserved | | | 1 | | |
| 1 | Reserved | | | 1 | | |
| 0 | Reserved | | | 1 | | |

Byte 4: Reserved

| Bit | Control Function | Description | Type | Power Up Condition | 0 | 1 |
|-----|------------------|-------------|------|--------------------|---|---|
| 7:0 | Reserved | | | | | |

Byte 5: Revision and Vendor ID Register

| Bit | Control Function | Description | Type | Power Up Condition | 0 | 1 |
|-----|------------------|-------------|------|--------------------|---------------|---|
| 7 | RID3 | Revision ID | R | 0 | rev = 0000 | |
| 6 | RID2 | | R | 0 | | |
| 5 | RID1 | | R | 0 | | |
| 4 | RID0 | | R | 0 | | |
| 3 | PVID3 | Vendor ID | R | 0 | Diodes = 0011 | |
| 2 | PVID3 | | R | 0 | | |
| 1 | PVID3 | | R | 1 | | |
| 0 | PVID3 | | R | 1 | | |

Byte 6: Device Type/Device ID Register

| Bit | Control Function | Description | Type | Power Up Condition | 0 | 1 |
|-----|------------------|-------------|------|--------------------|--|---|
| 7 | DTYPE1 | Device type | R | 0 | '00' = CG, '01' = ZDB, '10' = Reserve, '11' = ZDB | |
| 6 | DTYPE0 | | R | 0 | | |
| 5 | DID5 | Device ID | R | 0 | 000100 binary, 04Hex | |
| 4 | DID4 | | R | 0 | | |
| 3 | DID3 | | R | 0 | | |
| 2 | DID2 | | R | 1 | | |
| 1 | DID1 | | R | 0 | | |
| 0 | DID0 | | R | 0 | | |

Byte 7: Byte Count Register

| Bit | Control Function | Description | Type | Power Up Condition | 0 | 1 |
|-----|------------------|------------------------|------|--------------------|--|---|
| 7 | Reserved | | | 0 | | |
| 6 | Reserved | | | 0 | | |
| 5 | Reserved | | | 0 | | |
| 4 | BC4 | Byte count programming | RW | 0 | Writing to this register will configure how many bytes will be read back, default is 8 bytes | |
| 3 | BC3 | | RW | 1 | | |
| 2 | BC2 | | RW | 0 | | |
| 1 | BC1 | | RW | 0 | | |
| 0 | BC0 | | RW | 0 | | |

Plots

100MHz HCSL Clock

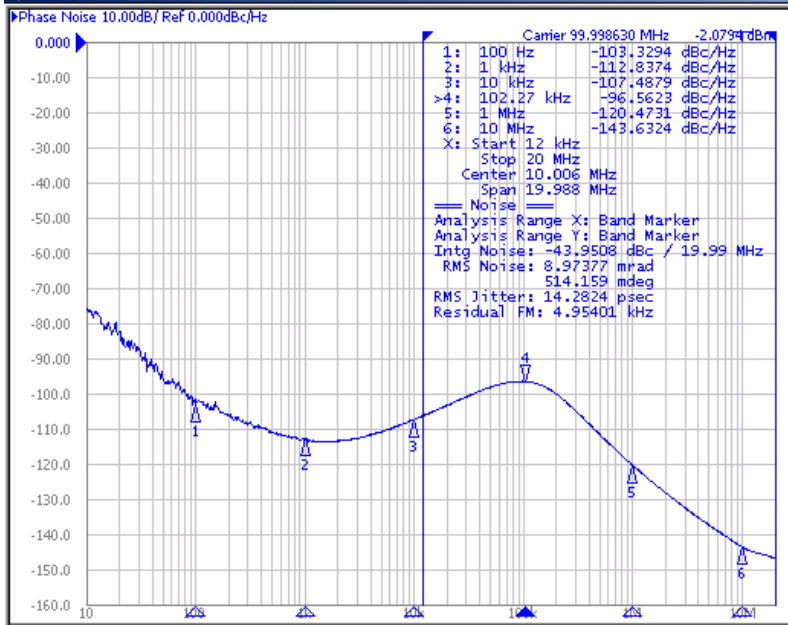

25MHz CMOS Clock

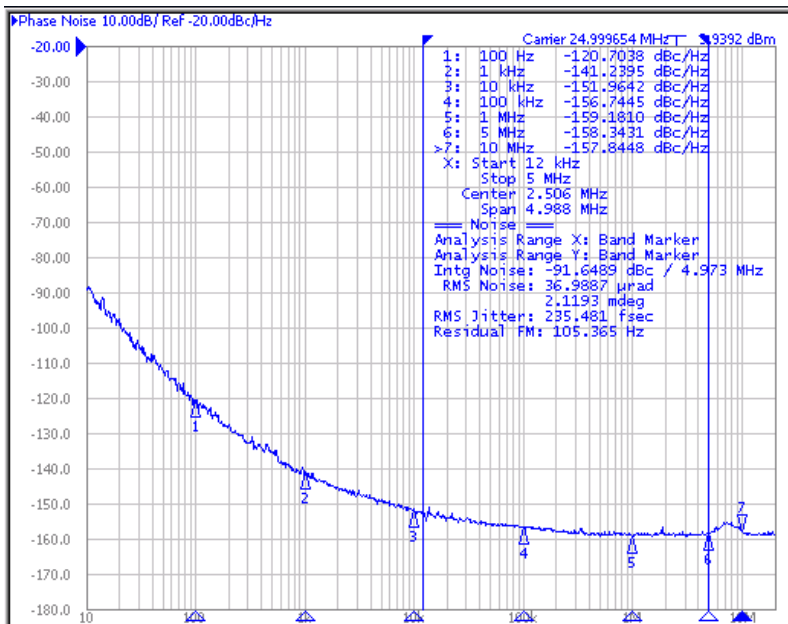

Low-Power HCSL Differential Output Test Load

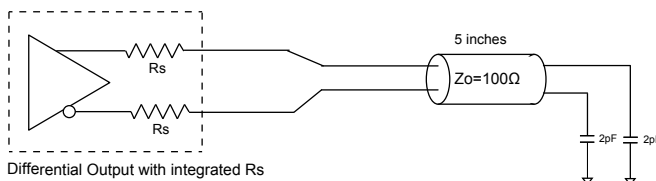

Figure 1. Low Power HCSL Test Circuit

REF Output Test Load

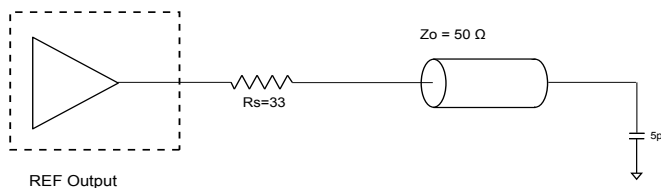

Figure 2. CMOS REF Test Circuit

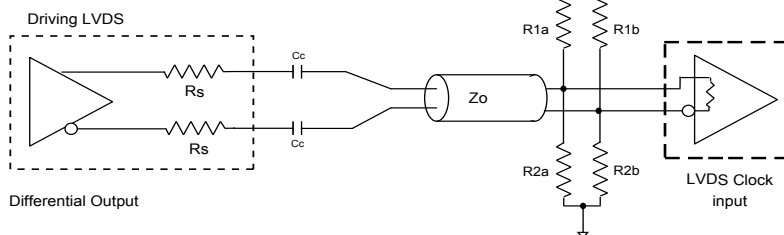

Figure 3. Differential Output driving LVDS

Alternate Differential Output Terminations

| Component | Receiver with termination | Receiver without termination | Unit |
|-----------|---------------------------|------------------------------|------|
| R1a, R1b | 10,000 | 140 | Ω |
| R2a, R2b | 5,600 | 75 | Ω |
| Cc | 0.1 | 0.1 | μF |
| VCM | 1.2 | 1.2 | V |

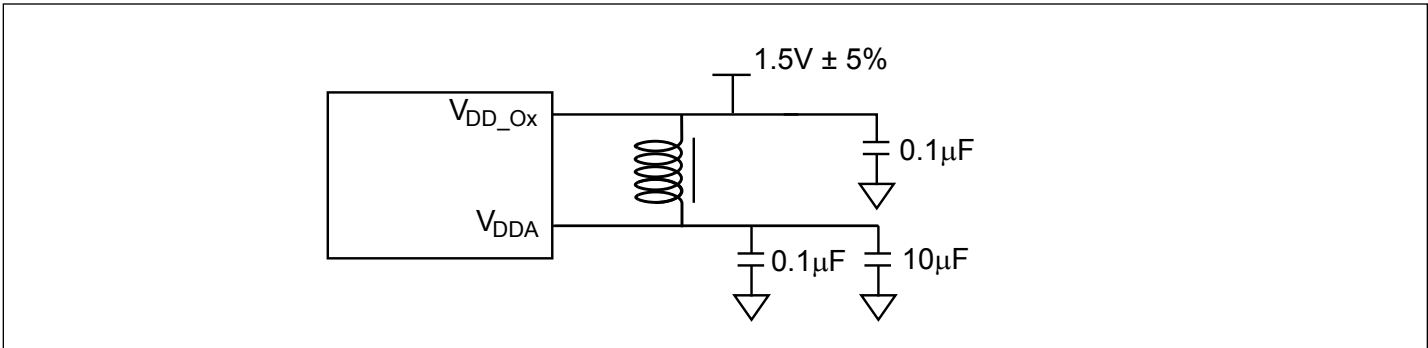
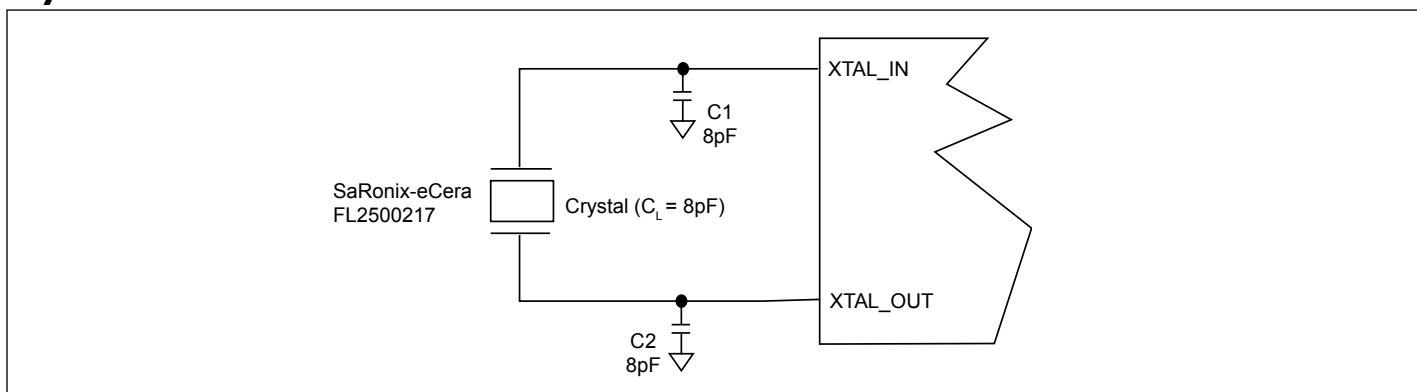

Figure 4. Power Supply Filter

Crystal circuit connection

The following diagram shows PI6CG15401 crystal circuit connection with a parallel crystal. For the $CL=8\text{pF}$ crystal, it is suggested to use $C1=8\text{pF}$, $C2=8\text{pF}$. $C1$ and $C2$ can be adjusted to fine tune to the target ppm of crystal oscillator according to different board layouts based on the following formular in the Crystal Capacitor Calculation diagram.

Crystal Oscillator Circuit



Crystal Capacitor Calculation

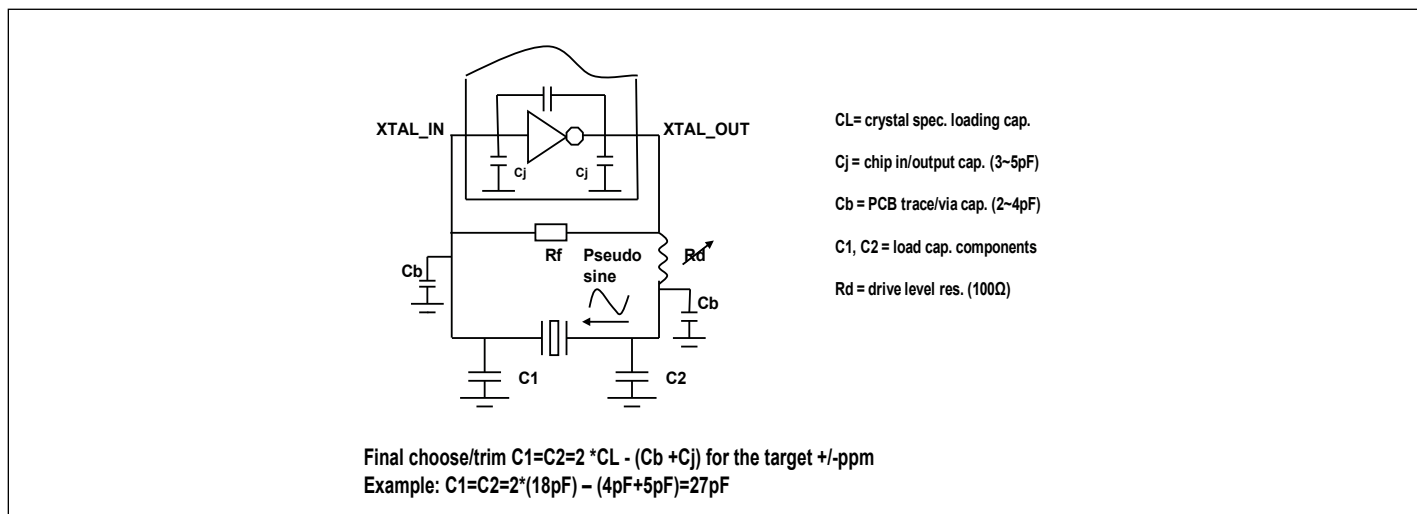

Recommended Crystal Specification

Diodes recommends:

- FL2500217, SMD 3.2x2.5(4P), 25MHz, $CL=8\text{pF}$, +/-20ppm, <http://www.Diodes.com/pdf/datasheets/se/FL.pdf>

Packaging Mechanical: 32-Pin TQFN (ZH)

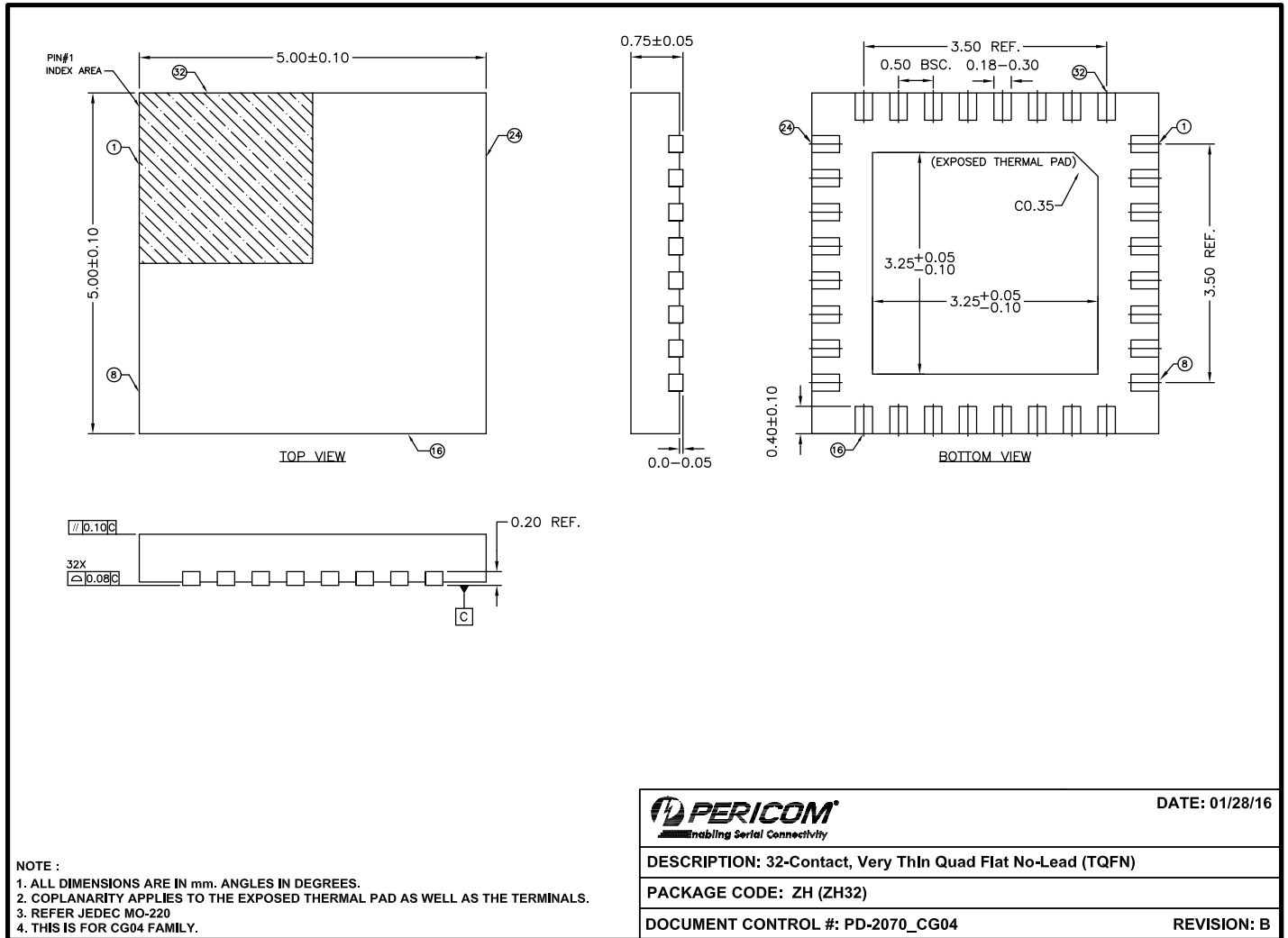

Note: For latest package info, please check: <http://www.Diodes.com/support/packaging/packaging-mechanicals-and-thermal-characteristics/>

Ordering Information⁽¹⁻³⁾

| Ordering Code | Package Code | Package Description | Operating Temperature |
|-----------------|--------------|---|-----------------------|
| PI6CG15401ZHIE | ZH | 32-Contact, Very Thin Quad Flat No-Lead (TQFN) | Industrial |
| PI6CG15401ZHIEX | ZH | 32-Contact, Very Thin Quad Flat No-Lead (TQFN), Tape & Reel | Industrial |

Notes:

1. Thermal characteristics can be found on the company web site at www.Diodes.com/packaging/
2. E = Pb-free and Green
3. Adding an X suffix = Tape/Reel

IMPORTANT NOTICE

DIODES INCORPORATED MAKES NO WARRANTY OF ANY KIND, EXPRESS OR IMPLIED, WITH REGARDS TO THIS DOCUMENT, INCLUDING, BUT NOT LIMITED TO, THE IMPLIED WARRANTIES OF MERCHANTABILITY AND FITNESS FOR A PARTICULAR PURPOSE (AND THEIR EQUIVALENTS UNDER THE LAWS OF ANY JURISDICTION).

Diodes Incorporated and its subsidiaries reserve the right to make modifications, enhancements, improvements, corrections or other changes without further notice to this document and any product described herein. Diodes Incorporated does not assume any liability arising out of the application or use of this document or any product described herein; neither does Diodes Incorporated convey any license under its patent or trademark rights, nor the rights of others. Any Customer or user of this document or products described herein in such applications shall assume all risks of such use and will agree to hold Diodes Incorporated and all the companies whose products are represented on Diodes Incorporated website, harmless against all damages.

Diodes Incorporated does not warrant or accept any liability whatsoever in respect of any products purchased through unauthorized sales channel.

Should Customers purchase or use Diodes Incorporated products for any unintended or unauthorized application, Customers shall indemnify and hold Diodes Incorporated and its representatives harmless against all claims, damages, expenses, and attorney fees arising out of, directly or indirectly, any claim of personal injury or death associated with such unintended or unauthorized application.

Products described herein may be covered by one or more United States, international or foreign patents pending. Product names and markings noted herein may also be covered by one or more United States, international or foreign trademarks.

This document is written in English but may be translated into multiple languages for reference. Only the English version of this document is the final and determinative format released by Diodes Incorporated.

LIFE SUPPORT

Diodes Incorporated products are specifically not authorized for use as critical components in life support devices or systems without the express written approval of the Chief Executive Officer of Diodes Incorporated. As used herein:

A. Life support devices or systems are devices or systems which:

1. are intended to implant into the body, or

2. support or sustain life and whose failure to perform when properly used in accordance with instructions for use provided in the labeling can be reasonably expected to result in significant injury to the user.

B. A critical component is any component in a life support device or system whose failure to perform can be reasonably expected to cause the failure of the life support device or to affect its safety or effectiveness.

Customers represent that they have all necessary expertise in the safety and regulatory ramifications of their life support devices or systems, and acknowledge and agree that they are solely responsible for all legal, regulatory and safety-related requirements concerning their products and any use of Diodes Incorporated products in such safety-critical, life support devices or systems, notwithstanding any devices- or systems-related information or support that may be provided by Diodes Incorporated. Further, Customers must fully indemnify Diodes Incorporated and its representatives against any damages arising out of the use of Diodes Incorporated products in such safety-critical, life support devices or systems.

Copyright © 2016, Diodes Incorporated

www.diodes.com