



Chipsmall Limited consists of a professional team with an average of over 10 year of expertise in the distribution of electronic components. Based in Hongkong, we have already established firm and mutual-benefit business relationships with customers from,Europe,America and south Asia,supplying obsolete and hard-to-find components to meet their specific needs.

With the principle of “Quality Parts,Customers Priority,Honest Operation,and Considerate Service”,our business mainly focus on the distribution of electronic components. Line cards we deal with include Microchip,ALPS,ROHM,Xilinx,Pulse,ON,Everlight and Freescale. Main products comprise IC,Modules,Potentiometer,IC Socket,Relay,Connector.Our parts cover such applications as commercial,industrial, and automotives areas.

We are looking forward to setting up business relationship with you and hope to provide you with the best service and solution. Let us make a better world for our industry!



Contact us

Tel: +86-755-8981 8866 Fax: +86-755-8427 6832

Email & Skype: info@chipsmall.com Web: www.chipsmall.com

Address: A1208, Overseas Decoration Building, #122 Zhenhua RD., Futian, Shenzhen, China



16-Bit 1.8-2.5V to 3.3V Level Shifting Transceiver with 3-State Outputs

Product Features

- PI74AVC164245 is designed for low voltage operation: 1.8V-2.5V to 3.3V
- Industrial operation at -40°C to $+85^{\circ}\text{C}$
- Packages available:
 - 48-pin plastic 300 mil SSOP (V)
 - 48-pin plastic 240 mil TSSOP (A)
 - 48-pin plastic 173 mil TVSOP (K)

Truth Table (each 8-bit section)

Inputs		Operation
$\overline{\text{OE}}$	DIR	
L	L	B data to A bus
L	H	A data to B bus
H	X	Isolation

Product Description

Pericom Semiconductor's AVC series of logic circuits are produced using the Company's advanced 0.35 micron CMOS technology, achieving industry leading performance.

Pericom Semiconductor's PI74AVC164245, a 16-bit (dual-octal) noninverting bus transceiver, contains two separate supply rails: B port (V_{CCB}), set at 3.3V, and A port (V_{CCA}), set to operate at 1.8-2.5V. This arrangement permits translation from a 1.8-2.5V to 3.3V environment and vice versa.

The PI74AVC164245 is designed for asynchronous communication between data buses.

To ensure the high impedance state during power up or power down, the output-enable (OE) input should be tied to V_{CC} through a pullup resistor: the minimum value of the resistor is determined by the current-sinking capability of the driver.

Logic Block Diagram

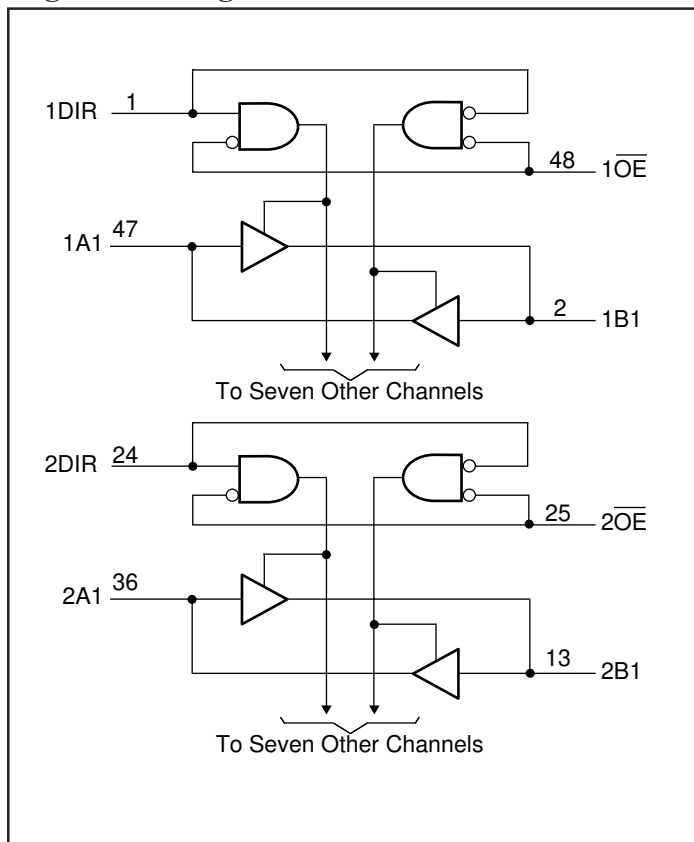

Product Pin Configuration

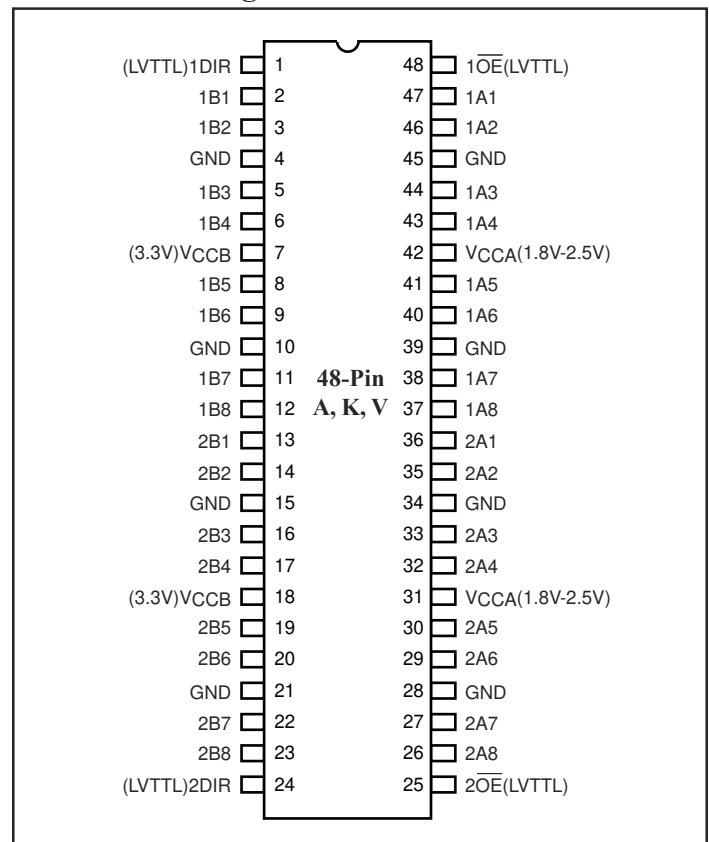

Maximum Ratings

(Absolute maximum ratings over operating free-air temperature range from V_{CCB} at 3.3V & V_{CCA} at 1.5 - 2.5V, unless otherwise noted)

Supply voltage range: V_{CCA}	-0.5V to 3.8V	Continuous output current, I_O	$\pm 50\text{mA}$
V_{CCB}	-0.5V to 4.6V	Continuous current through each V_{CC} or GND	$\pm 100\text{mA}$
Input Voltage Range, V_I Except I/O ports ⁽¹⁾	-0.5V to 4.6V	Package thermal impedance, θ_{JA} ⁽³⁾ : A package	89°C/W
I/O port A ⁽²⁾ ...	-0.5V to $V_{CCA}+0.5\text{V}$	K package	58°C/W
I/O port B ⁽¹⁾	-0.5V to $V_{CCB}+0.5\text{V}$	V package	94°C/W
Input clamp current, I_{IK} ($V_I < 0$)	-50mA	Storage temperature range, T_{STG}	-65°C to 150°C
Output clamp current, I_{OK} ($V_O < 0$)	-50mA		

Note:

Stresses greater than those listed under MAXIMUM RATINGS may cause permanent damage to the device. This is a stress rating only and functional operation of the device at these or any other conditions above those indicated in the operational sections of this specification is not implied. Exposure to absolute maximum rating conditions for extended periods may affect reliability.

Recommended Operating Conditions for V_{CCB} at 3.3V⁽⁴⁾

		Min.	Max.	Units
V_{CCB}	Supply voltage	3.0	3.6	V
V_{IH}	High-level voltage	2		
V_{IL}	Low-level voltage		0.8	
V_{IB}	Input Voltage	0	V_{CCB}	
V_{OB}	Output Voltage	0	V_{CCB}	
I_{OH}	High-level output current		-12	mA
I_{OL}	Low-level output current		12	
$\Delta t/\Delta v$	Input transition rise or fall rate		10	ns/V
T_A	Operating free-air temperature	-40	85	°C

Notes:

1. This value is limited to 4.6V maximum.
2. This value is limited to 3.8V maximum.
3. The package thermal impedance is calculated in accordance with JESD 51.
4. To ensure proper device operation, all unused device inputs must be held at the associated V_{CC} or GND.

Recommended Operating Conditions for V_{CCA} at 2.5V⁽⁴⁾

		Min.	Max.	Units
V_{CCA}	Supply voltage	2.3	2.7	V
V_{IH}	High-level voltage	$V_{CCA} = 2.3\text{V to } 2.7\text{V}$	1.7	
V_{IL}	Low-level voltage	$V_{CCA} = 2.3\text{V to } 2.7\text{V}$	0.7	
V_{IA}	Input voltage	0	V_{CCA}	
V_{OA}	Output voltage	0	V_{CCA}	
I_{OH}	High-level output current	$V_{CCA} = 2.3\text{V}$	-8	mA
		$V_{CCA} = 2.7\text{V}$	-12	
I_{OL}	Low-level output current	$V_{CCA} = 2.3\text{V}$	8	
		$V_{CCA} = 2.7\text{V}$	12	
$\Delta t/\Delta v$	Input transition rise or fall rate		10	ns/V
T_A	Operating free-air temperature	-40	85	°C

Recommended Operating Conditions for V_{CCA} at 1.8V⁽⁴⁾

		Min.	Max.	Units
V_{CCA}	Supply voltage	1.65	1.95	V
V_{IH}	High-level voltage	$V_{CCA} = 1.65V$ to $1.95V$	$0.65 \times V_{CCA}$	
V_{IL}	Low-level voltage	$V_{CCA} = 1.65V$ to $1.95V$	$0.35 \times V_{CCA}$	
V_{IB}	Input voltage	0	V_{CCA}	
V_{OA}	Output voltage	0	V_{CCA}	
I_{OH}	High-level output current	$V_{CCA} = 1.65V$	-4	mA
		$V_{CCA} = 1.95V$	-8	
I_{OL}	Low-level output current	$V_{CCA} = 1.65V$	4	
		$V_{CCA} = 1.95V$	8	
$\Delta t/\Delta v$	Input transition rise or fall rate		10	ns/V
T_A	Operating free-air temperature	-40	85	°C

Notes:

1. Value limited to 4.6V maximum.
2. Value limited to 3.8V maximum.
3. Package thermal impedance is calculated in accordance with JESD 51.
4. To ensure proper device operation, all unused device inputs must be held at the associated V_{CC} or GND.

Electrical Characteristics (V_{CCB}) (Over recommended operating free-air temperature range for $V_{CCB} = 3.3V$)

Parameters		Test Conditions	V_{CCB}	Min.	Typ. [†]	Max.	Units
V_{OH} (A to B)	$I_{OH} = -100\mu A$		3.0V	2.8			V
			3.6V	3.4			
	$I_{OH} = -12mA$		3.0V	2.2			
			3.6V	2.8			
V_{OL} (A to B)	$I_{OL} = 100\mu A$		3.0V			0.2	V
			3.6V			0.2	
	$I_{OL} = 12mA$		3.0V			0.5	
			3.6V			0.5	
I_I	Control Inputs	$V_I = V_{CCB}$ or GND	3.6V			± 5	μA
I_{OZ}^{\ddagger}	A or B ports	$V_O = V_{CCB}$ or GND	3.6V			± 10	
I_{CC}		$V_I = V_{CCB}$ or GND, $I_O = 0$	3.6V			20	
ΔI_{CC}^*		One input at $V_{CCB} - 0.6V$, Other inputs at V_{CCB} or GND	3.0V to 3.6V			500	
C_I	Control Inputs	$V_I = V_{CCB}$ or GND	3.3V		4.5		pF
C_{IO}	A or B ports	$V_O = V_{CCB}$ or GND	3.3V		6.5		

Notes:

- [†] Typical values are measured at $V_{CC} = 3.3V$, $T_A = 25^\circ C$
- [‡] For I/O ports, the parameter I_{OZ} includes the input leakage current.
- * This is the increase in supply current for each input that is at one of the specified TTL voltage levels rather than at 0 or the associated V_{CC} .

Electrical Characteristics (V_{CCA}) (Over recommended operating free-air temperature range for V_{CCA} = 2.5V)

Parameters		Test Conditions	V _{CCA}	Min.	Typ. [†]	Max.	Units
V _{OH} (B to A)		I _{OH} = -100μA	2.3V to 2.7V	V _{CC} -0.1			V
		I _{OH} = -8mA	2.3V	1.7			
		I _{OH} = -12mA	2.7V	2.0			
V _{OL} (B to A)		I _{OL} = 100μA	2.3V to 2.7V			0.2	V
		I _{OL} = 8mA	2.3V			0.4	
		I _{OL} = 12mA	2.7V			0.5	
I _I	Control Inputs	V _I = V _{CCA} or GND	2.7V			±5	μA
I _{OZ} [‡]	A or B ports	V _O = V _{CCA} or GND	2.7V			±10	
I _{CC}		V _I = V _{CCA} or GND, I _O = 0	2.7V			30	
ΔI _{CC} [*]		One input at V _{CCA} -0.6V, Other inputs at V _{CCA} or GND	2.3V to 2.7V			500	
C _I	Control Inputs	V _I = V _{CCA} or GND	2.5V		4.5		pF
C _{IO}	A or B ports	V _O = V _{CCA} or GND	2.5V		6.5		

Electrical Characteristics (V_{CCA}) (Over recommended operating free-air temperature range for V_{CCA} = 1.8V)

Parameters		Test Conditions	V _{CCA}	Min.	Typ. ^{**}	Max.	Units
V _{OH} (B to A)		I _{OH} = -100μA	1.65V to 1.95V	V _{CC} -0.1			V
		I _{OH} = -4mA	1.65V	1.3			
		I _{OH} = -8mA	1.95V	1.4			
V _{OL} (B to A)		I _{OL} = 100μA	1.65V			0.2	V
		I _{OL} = 4mA	1.95V			0.3	
		I _{OL} = 8mA	1.95V			0.4	
I _{OZ} ^{***}	A or B ports	V _O = V _{CCA} or GND	1.95V			±5	μA
I _{CC}		V _I = V _{CCA} or GND, I _O = 0	1.95V			±20	
ΔI _{CC} [*]		One input at V _{CCA} -0.6V, Other inputs at V _{CCA} or GND	1.65V to 1.95V			300	
C _I	Control Inputs	V _I = V _{CCA} or GND	1.8V		4.5		pF
C _{IO}	A or B ports	V _O = V _{CCA} or GND	1.8V		6.5		

Notes:

* The increase in supply current for each input at one of the specified TTL voltage levels rather than at the associated V_{CC}.

** Typical values are measured at V_{CC} = 2.5V or 1.8V, T_A = 25°C

*** For I/O ports, the parameter I_{OZ} includes the input leakage current.

Switching Characteristics

(Over recommended operating free-air temperature range, $C_L = 30\text{pF}$ (unless otherwise noted), see Figures 1, 2, 3)

Parameter	From (Input)	To (Output)	PI74AVC164245				PI74AVC164245A				Units
			$V_{CCB} = 3.3V \pm 0.3V$				$V_{CCB} = 3.3V \pm 0.3V$				
			$V_{CCA} = 1.8V \pm 0.15V$		$V_{CCA} = 2.5V \pm 0.2V$		$V_{CCA} = 1.8V \pm 0.15V$		$V_{CCA} = 2.5V \pm 0.2V$		
			Min.	Max.	Min.	Max.	Min.	Max.	Min.	Max.	
t_{PD}	A	B	1.5	4.6	1.5	4.2	1.5	3.5	1.0	3.0	ns
	B	A	1.5	4.4	1.5	4.0	1.5	3.5	1.0	2.8	
t_{EN}	\overline{OE}	B	1.7	5.5	1.7	4.5	1.7	4.5	1.2	3.5	
t_{DIS}	\overline{OE}	B	1.5	5.5	1.5	4.5	1.5	4.5	1.0	3.5	
t_{EN}	\overline{OE}	A	1.7	5.5	1.7	4.5	1.7	4.5	1.2	3.5	
t_{DIS}	\overline{OE}	A	2.0	5.5	2.0	4.5	2.0	4.5	1.5	3.5	
$t_{sk(o)}^{(1)}$						0.5				0.3	
$t_{sk(b)}^{(1)}$						0.3				0.25	

Note:

- This is the skew between any two outputs of the same package, and switching in the same direction. For $t_{sk(o)}$, Output 1 and Output 2 are any two outputs. For $t_{sk(b)}$, Output 1 and Output 2 are in the same bank. These parameters are warranted but not production tested.

Operating Characteristics, $T_A = 25^\circ\text{C}$

Parameters		Test Conditions	$V_{CCA} = 2.5V$ $V_{CCB} = 3.3V$	Units
			Typical	
C_{PD} Power Dissipation Capacitance	Outputs Enabled (A or B)	$C_L = 30\text{pF}$, $F = 10\text{MHz}$	56	pF
	Outputs Disabled		6	

Parameter Measurement Information, $V_{CCA} = 1.5V \pm 0.10V$

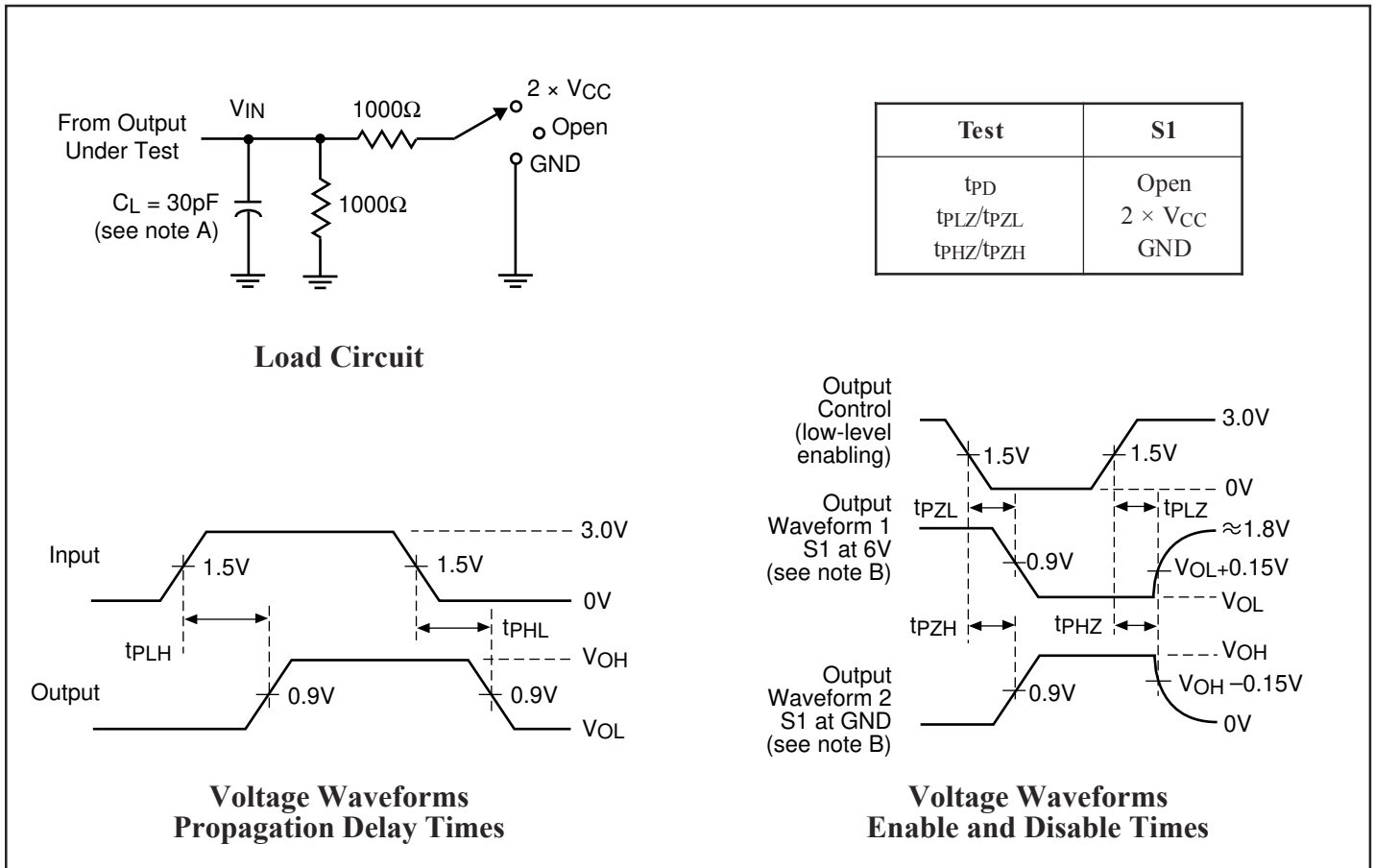

Figure 1. Load Circuit and Voltage Waveforms

Notes:

- A. C_L includes probe and jig capacitance.
- B. Waveform 1 is for an output with internal conditions such that the output is low except when disabled by the output control. Waveform 2 is for an output with internal conditions such that the output is high except when disabled by the output control.
- C. All input pulses are supplied by generators having the following characteristics: $PRR \leq 10Mz$, $Z_O = 50\Omega$, $t_R \leq 2.5ns$, $t_F \leq 2.5ns$.
- D. The outputs are measured one at a time with one transition per measurement.
- E. t_{PLZ} and t_{PHZ} are the same as t_{DIS} .
- F. t_{PZL} and t_{PZH} are the same as t_{EN} .
- G. t_{PLH} and t_{PHL} are the same as t_{PD} .

Parameter Measurement Information, $V_{CCA} = 2.5V \pm 0.2V$

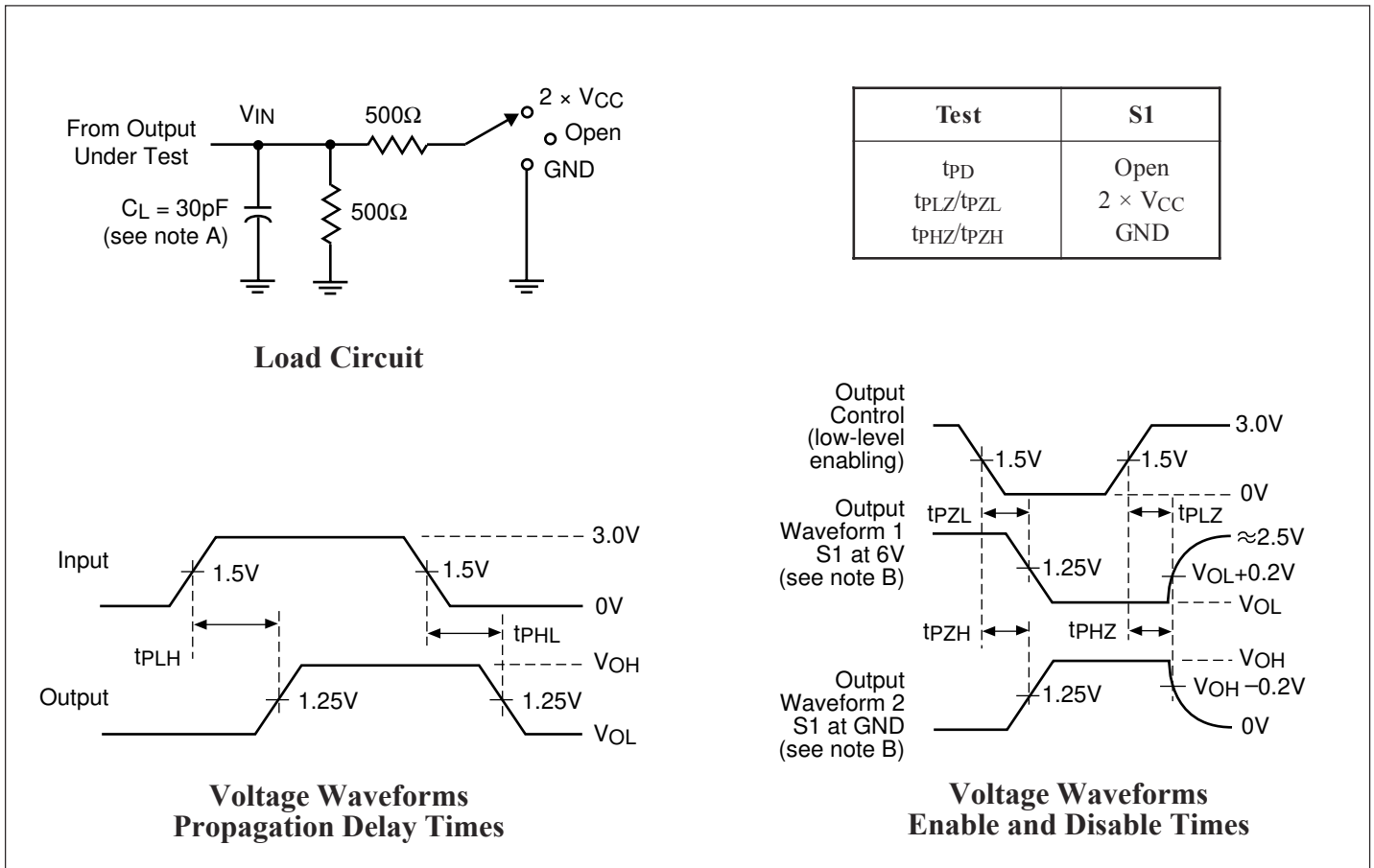

Figure 2. Load Circuit and Voltage Waveforms

Notes:

- A. C_L includes probe and jig capacitance.
- B. Waveform 1 is for an output with internal conditions such that the output is low except when disabled by the output control.
Waveform 2 is for an output with internal conditions such that the output is high except when disabled by the output control.
- C. All input pulses are supplied by generators having the following characteristics: $PRR \leq 10Mz$, $Z_O = 50\Omega$, $t_R \leq 2.5ns$, $t_F \leq 2.5ns$.
- D. The outputs are measured one at a time with one transition per measurement.
- E. t_{PLZ} and t_{PHZ} are the same as t_{DIS} .
- F. t_{PZL} and t_{PZH} are the same as t_{EN} .
- G. t_{PLH} and t_{PHL} are the same as t_{PD} .

Parameter Measurement Information, $V_{CCB} = 3.3V \pm 0.3V$

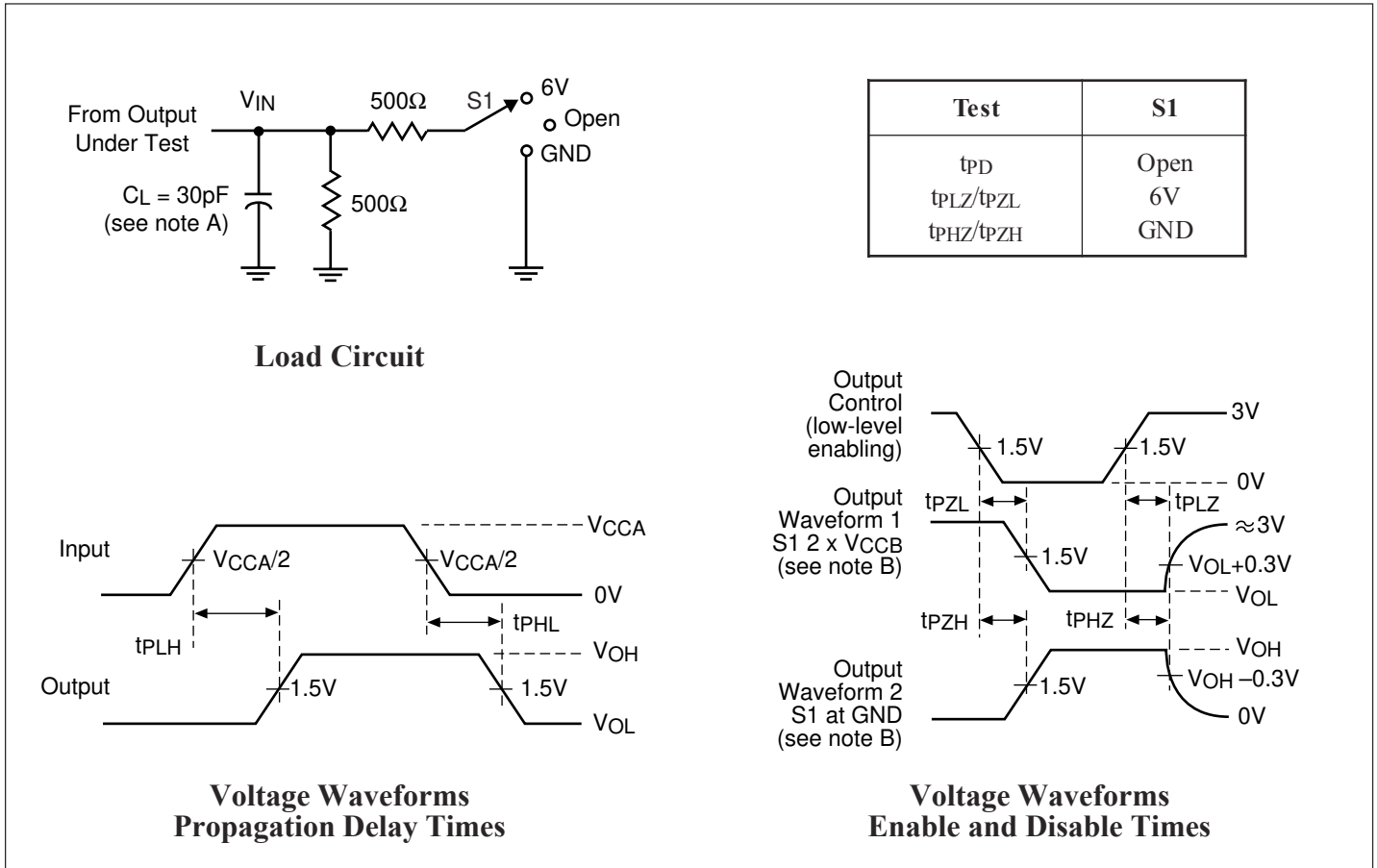
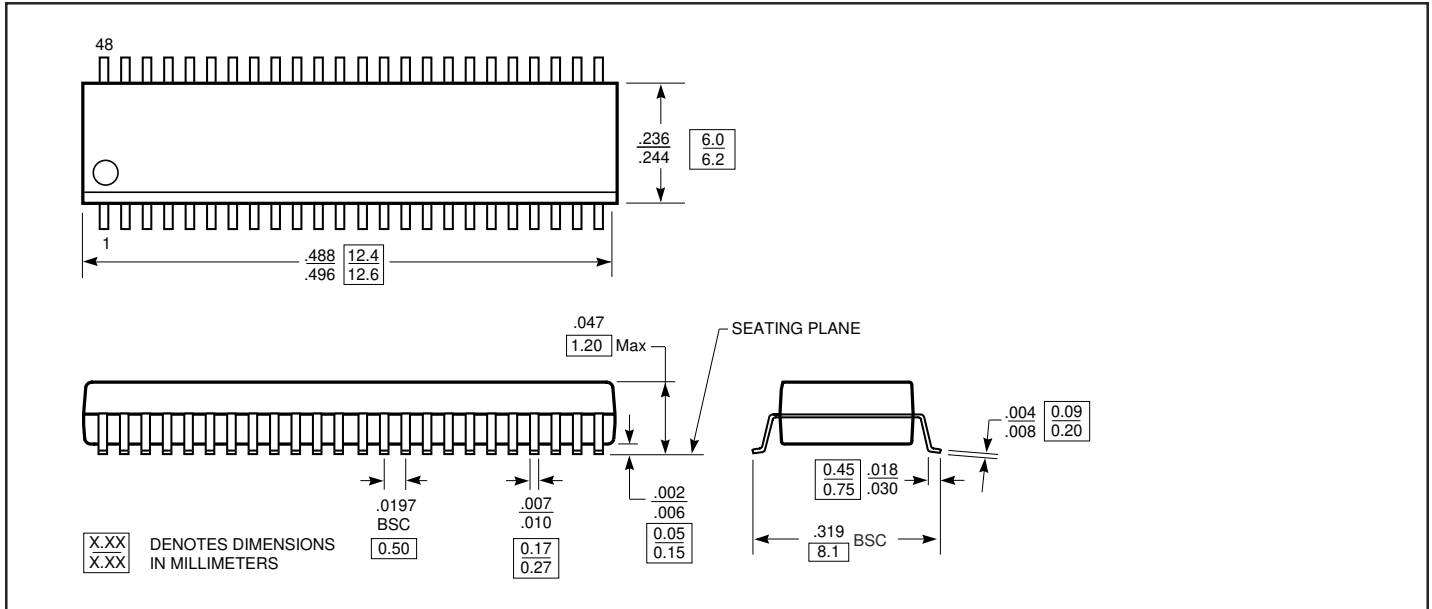

Figure 3. Load Circuit and Voltage Waveforms

Notes:

- A. C_L includes probe and jig capacitance.
- B. Waveform 1 is for an output with internal conditions such that the output is low except when disabled by the output control.
 Waveform 2 is for an output with internal conditions such that the output is high except when disabled by the output control.
- C. All input pulses are supplied by generators having the following characteristics: $PRR \leq 10Mz$, $Z_O = 50\Omega$, $t_R \leq 2.5ns$, $t_F \leq 2.5ns$.
- D. The outputs are measured one at a time with one transition per measurement.
- E. t_{PLZ} and t_{PHZ} are the same as t_{DIS} .
- F. t_{PZL} and t_{PZH} are the same as t_{EN} .
- G. t_{PLH} and t_{PHL} are the same as t_{PD} .

48-Pin TSSOP (A) Package



48-Pin SSOP (V) Package

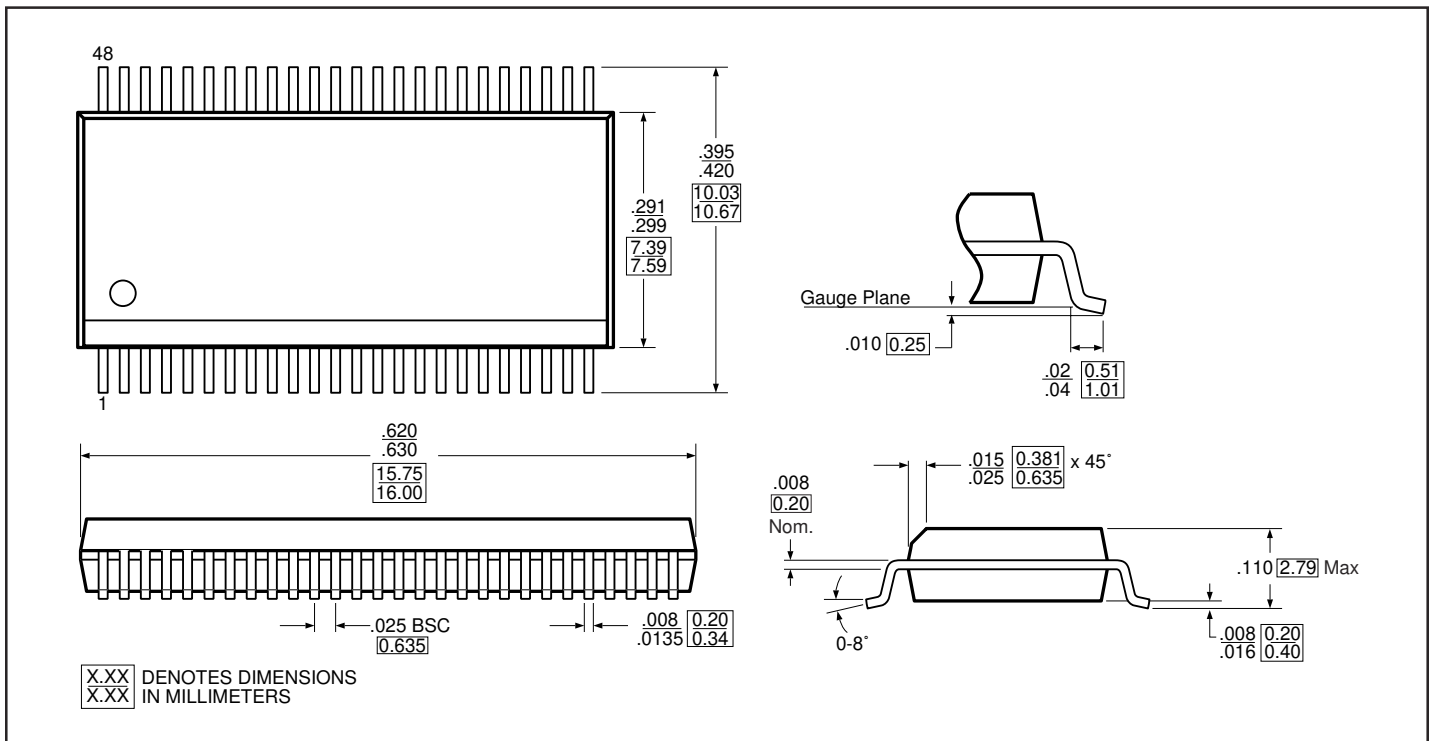

48-Pin TVSOP (K) Package

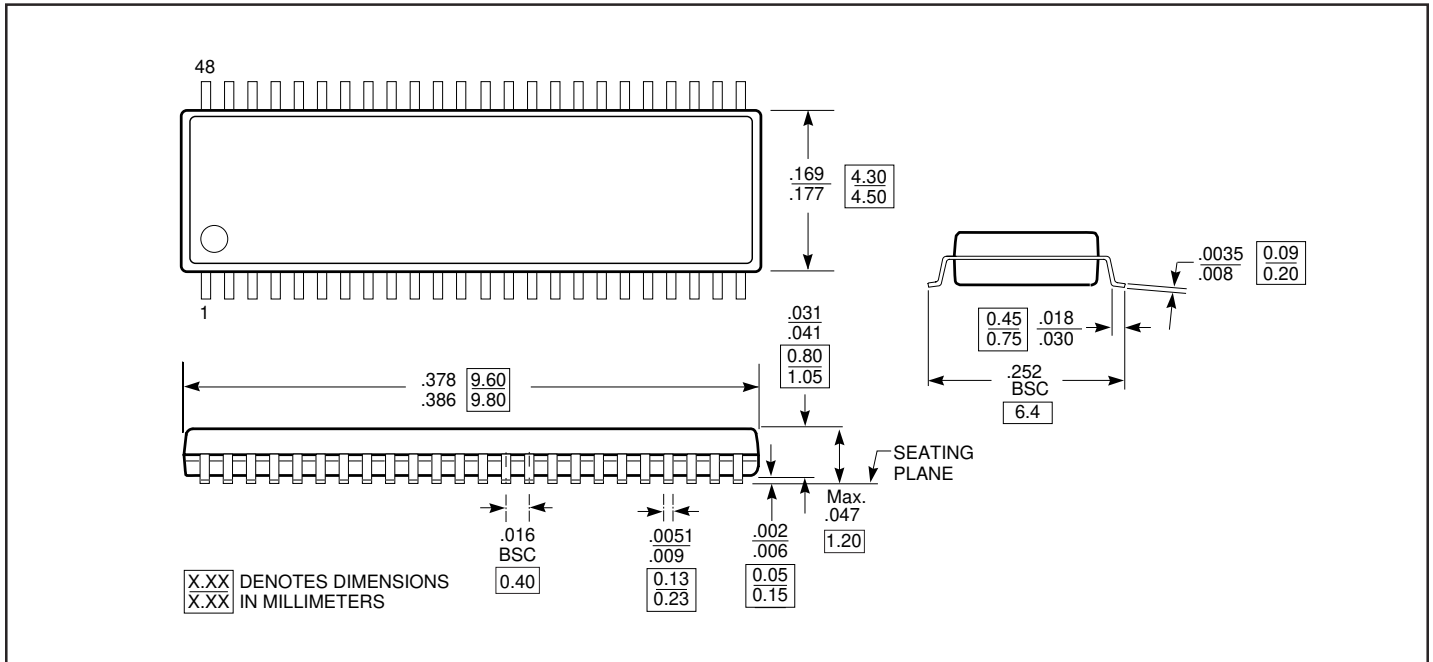

Ordering Information

Ordering Data		Description
Blank Speed	A Speed	
PI74AVC164245V	PI74AVC164245AV	48-pin, 300-mil wide plastic SSOP
PI74AVC164245A	PI74AVC164245AA	48-pin, 240-mil wide plastic TSSOP
PI74AVC164245K	PI74AVC164245AK	48-pin, 173-mil wide plastic TVSOP