



Chipsmall Limited consists of a professional team with an average of over 10 year of expertise in the distribution of electronic components. Based in Hongkong, we have already established firm and mutual-benefit business relationships with customers from,Europe,America and south Asia,supplying obsolete and hard-to-find components to meet their specific needs.

With the principle of "Quality Parts,Customers Priority,Honest Operation,and Considerate Service",our business mainly focus on the distribution of electronic components. Line cards we deal with include Microchip,ALPS,ROHM,Xilinx,Pulse,ON,Everlight and Freescale. Main products comprise IC,Modules,Potentiometer,IC Socket,Relay,Connector.Our parts cover such applications as commercial,industrial, and automotives areas.

We are looking forward to setting up business relationship with you and hope to provide you with the best service and solution. Let us make a better world for our industry!



Contact us

Tel: +86-755-8981 8866 Fax: +86-755-8427 6832

Email & Skype: info@chipsmall.com Web: www.chipsmall.com

Address: A1208, Overseas Decoration Building, #122 Zhenhua RD., Futian, Shenzhen, China



14-Bit Registered Buffer
Product Features

- PI74 SSTV16857 is designed for low-voltage operation, $V_{DD} = V_{DDQ} = 2.3V$ to $2.7V$
- Supports SSTL_2 Class I and II specifications
- SSTL_2 Input and Output Levels
- Designed for DDR Memory
- Flow-Through Architecture
- Packaging:
 - 48-pin, 240-mil wide plastic TSSOP (A)
 - 48-pin, 240-mil wide Lead-Free plastic TSSOP (AE)

Product Description

Pericom Semiconductor's PI74SSTV16857 series of logic circuits are produced using the Company's advanced 0.35 micron CMOS technology, achieving industry leading speed.

The 14-bit PI74SSTV16857 universal bus driver is designed for 2.3V to 2.7V V_{DD} operation and SSTL_2 I/O Levels except for the \overline{RESET} input which is LVCMOS.

Data flow from D to Q is controlled by the differential clock, CLK, \overline{CLK} and \overline{RESET} . Data is triggered on the positive edge of CLK. \overline{CLK} must be used to maintain noise margins.

\overline{RESET} must be supported with LVCMOS levels as V_{REF} may not be stable during power-up. \overline{RESET} is asynchronous and is intended for power-up only and when low assures that all of the registers reset to the Low State, Q outputs are low, and all input receivers, data and clock, are switched off.

Pericom's PI74SSTV16857 is characterized for operation from 0° to $70^{\circ}C$.

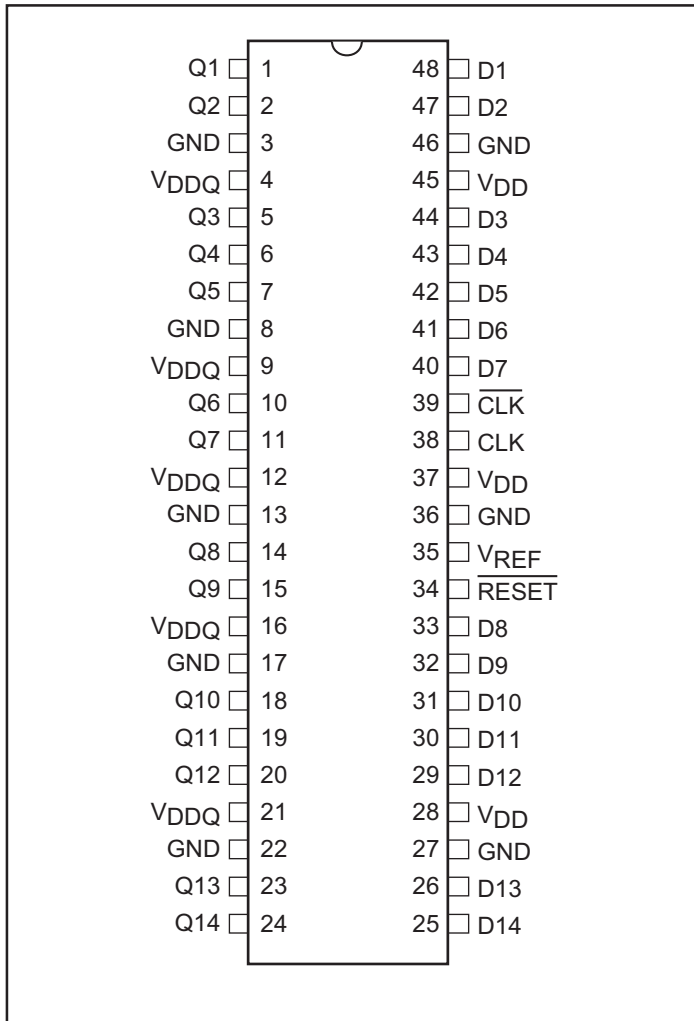
Product Pin Configuration

Product Pin Description

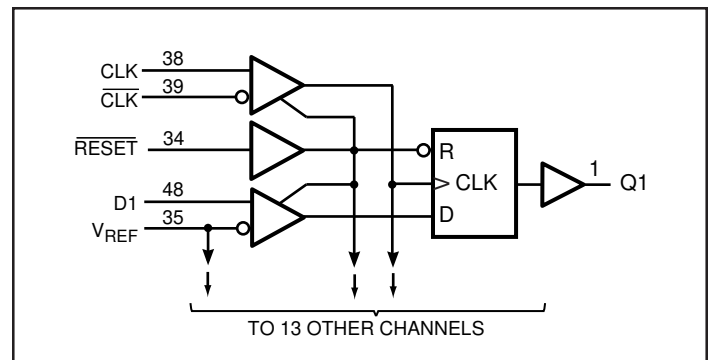
Pin Name	Description
\overline{RESET}	Reset (Active Low)
CLK	Clock Input
\overline{CLK}	Clock Input
D	Data Input
Q	Data Output
GND	Ground
V_{DD}	Core Supply Voltage
V_{DDQ}	Output Supply Voltage
V_{REF}	Input Reference Voltage

Logic Block Diagram

Truth Table⁽¹⁾

Inputs				Outputs
RESET	CLK	CLK	D	Q
L	X	X	X	L
H	↑	↓	H	H
H	↑	↓	L	L
H	L or H	L or H	X	Qo ⁽²⁾

Notes:

- H = High Signal Level
L = Low Signal Level
↑ = Transition LOW-to-HIGH
↓ = Transition HIGH-to-LOW
X = Irrelevant
- Output level before the indicated steady state input conditions were established.

Maximum Ratings

(Above which the useful life may be impaired. For user guidelines, not tested.)

Item	Symbol/Conditions	Ratings	Units
Storage temperature	T_{stg}	-65 to 150	°C
Supply voltage	V_{DD} or V_{DDQ}	-0.5 to 3.6	V
Input voltage ⁽¹⁾	V_I	-0.5 to $V_{DD} + 0.5$	
Output voltage ^(1,2)	V_O	-0.5 to $V_{DDQ} + 0.5$	
Input clamp current	$I_{IK}, V_I < 0$	-50	
Output clamp current	$I_{OK}, V_O < 0$	±50	mA
Continuous output current	$I_O, V_O = 0$ to V_{DDQ}	±50	
V_{DD}, V_{DDQ} or GND current/pin	I_{DD}, I_{DDQ} or I_{GND}	±100	
Package Thermal Impedance ⁽³⁾	θ_{JA}	70	°C/W

Note:

Stresses greater than those listed under MAXIMUM RATINGS may cause permanent damage to the device. This is a stress rating only and functional operation of the device at these or any other conditions above those indicated in the operational sections of this specification is not implied. Exposure to absolute maximum rating conditions for extended periods may affect reliability.

Notes:

- The input and output negative voltage ratings may be excluded if the input and output clamp ratings are observed.
- This current will flow only when the output is in the high state level $V_O > V_{DDQ}$.
- The package thermal impedance is calculated in accordance with JESD 51.

Recommended Operating Conditions

Parameters	Description		Min.	Nom.	Max.	Units
V _{DD}	Supply Voltage		2.3	2.5	2.7	V
V _{DDQ}	I/O Supply Voltage		2.3	2.5	2.7	
V _{REF}	Reference Voltage V _{REF} = 0.5X V _{DDQ}		1.15	1.25	1.35	
V _{TT}	Termination Voltage		V _{REF} -0.04	V _{REF}	V _{REF} +0.04	
V _{IH}	DC Input High Voltage	Data Inputs	V _{REF} +0.15		V _{DDQ} +0.3	
V _{IL}	DC Input Low Voltage		-0.3		V _{REF} -0.15	
V _{IH}	Input High Voltage	$\overline{\text{RESET}}$	1.7		V _{DDQ} +0.3	
V _{IL}	Input Low Voltage		-0.3		0.8	
V _{IN}	Input Voltage Level	CLK, $\overline{\text{CLK}}$	-0.3			
V _{ID}	Input Differential Voltage		0.36		V _{DDQ} +0.6	
V _{IX}	Cross Point Voltage of Differential Clock Pair		(V _{DDQ} /2) -0.2		(V _{DDQ} /2) +0.2	
I _{OH}	High-Level Output Current				-20	mA
I _{OL}	Low-Level Output Current				20	
T _A	Operating Free-Air Temperature		0		70	°C

DC Electrical Characteristics

 (Over the Operating Range, $T_A = 0^\circ\text{C}$ to $+70^\circ\text{C}$, $V_{DD} = 2.5\text{V} \pm 200\text{mV}$, $V_{DDQ} = 2.5\text{V} \pm 200\text{mV}$)

Parameters		Test Conditions	VCC	Min.	Typ. ⁽¹⁾	Max.	Units
V_{IK}		$I_I = -18\text{mA}$	2.3V			-1.2	V
V_{OH}		$I_{OH} = -100\mu\text{A}$	2.3V-2.7V	$V_{ID} - 0.2\text{V}$			
		$I_{OH} = -16\text{mA}$	2.3V	1.95			
V_{OL}		$I_{OL} = 100\mu\text{A}$	2.3V-2.7V			0.2	
		$I_{OH} = 16\text{mA}$	2.3V			0.35	
I_I	All Inputs,	$V_I = V_{ID}$ or GND	2.7V			5	μA
I_{DD}	Standby (Static)	$\overline{\text{RESET}} = \text{GND}$				10	
	Operating Static	$V_I = V_{IH}(\overline{\text{AC}})$ or $V_I(\text{AC})$, $\overline{\text{RESET}} = V_{ID}$				56	mA
I_{DD}	Dynamic Operating - Clock only	$\overline{\text{RESET}} = V_{ID}$ $V_I = V_{IH}(\overline{\text{CK}})$ or $V_{IH}(\text{CK})$, CK and $\overline{\text{CK}}$ switching 50% duty cycle	$I_O = 0$	2.7V		52	$\mu\text{A}/$ clock MHz
	Dynamic Operating - per each data input	$\overline{\text{RESET}} = V_{ID}$ $V_I = V_{IH}(\overline{\text{AQ}})$ or $V_{IH}(\text{AQ})$, CK and $\overline{\text{CK}}$ switching 50% duty cycle. One data input switching at half clock frequency, 50% duty cycle				9	$\mu\text{A}/$ clock MHz Data
r_{GH}	Output High	$I_{GH} = -20\text{mA}$	2.3V-2.7V	7		20	ohm
r_{GL}	Output Low	$I_{GL} = 20\text{mA}$	2.3V-2.7V	7		20	
$r_{d(\Delta)}$	$r_{GH}r_{GL}$	$I_O = 20\text{mA}$, $T_A = 25^\circ\text{C}$	2.5V			6	
C_I	Data inputs	$V_I = V_{RF} \pm 350\text{mV}$			2.0		3.5
	CK and $\overline{\text{CK}}$	$V_{IK} = 1.25\text{V}$, $V_{IH} = 360\text{mV}$	2.5V	2.0		3.5	

Notes:

 4. Typical values are at $V_{DD} = \text{Nominal } V_{DD}$, $T_A = +25^\circ\text{C}$.

Timing Requirements (over recommended operating free-air temperature range, unless otherwise noted)

		$V_{DD}=2.5V \pm 0.2V$		Unit
		Min.	Max.	
f_{clock}	Clock Frequency		200	MHz
t_W	Pulse Duration	2.5		ns
t_{act}	Differential inputs active time ⁽⁵⁾	22		
t_{inact}	Output slew rate differential inputs inactive time ⁽⁶⁾	22		
t_{SU}	Setup time, fast slew rate ^(7,9)	Data before $CK\uparrow$, $\overline{CK}\downarrow$	0.75	
	Setup time, slow slew rate ^(8,9)		0.9	
t_h	Hold time, fast slew rate ^(7,9)	Data before $CK\uparrow$, $\overline{CK}\downarrow$	0.75	
	Hold time, slow slew rate ^(8,9)		0.9	

Notes:

5. Data inputs must be held low for a minimum time of t_{act} min, after \overline{RESET} is taken high
6. Data and clock inputs must be held at valid levels (not floating) for a minimum time of t_{inact} min, after \overline{RESET} is taken low.
7. Data signal input slew rate ≥ 1 V/ns
8. Data signal input slew rate $\geq 0.5V/ns$ and $<1V/ns$
9. CLK, \overline{CLK} input slew rates are ≥ 1 V/ns.

Switching characteristics (over recommended operating free-air temperature range, unless otherwise noted.)

(See test circuits and switching waveforms).

Parameter	From (Input)	To (Output)	$V_{DD}= 2.5V \pm 0.2V$			Units
			Min.	Typ.	Max.	
f_{max}			200			MHz
t_{pd}	CLK, \overline{CLK}	Q	1.1		2.8	ns
t_{pl}	\overline{RESET}	Q			5.0	

Test Circuit and Switching Waveforms

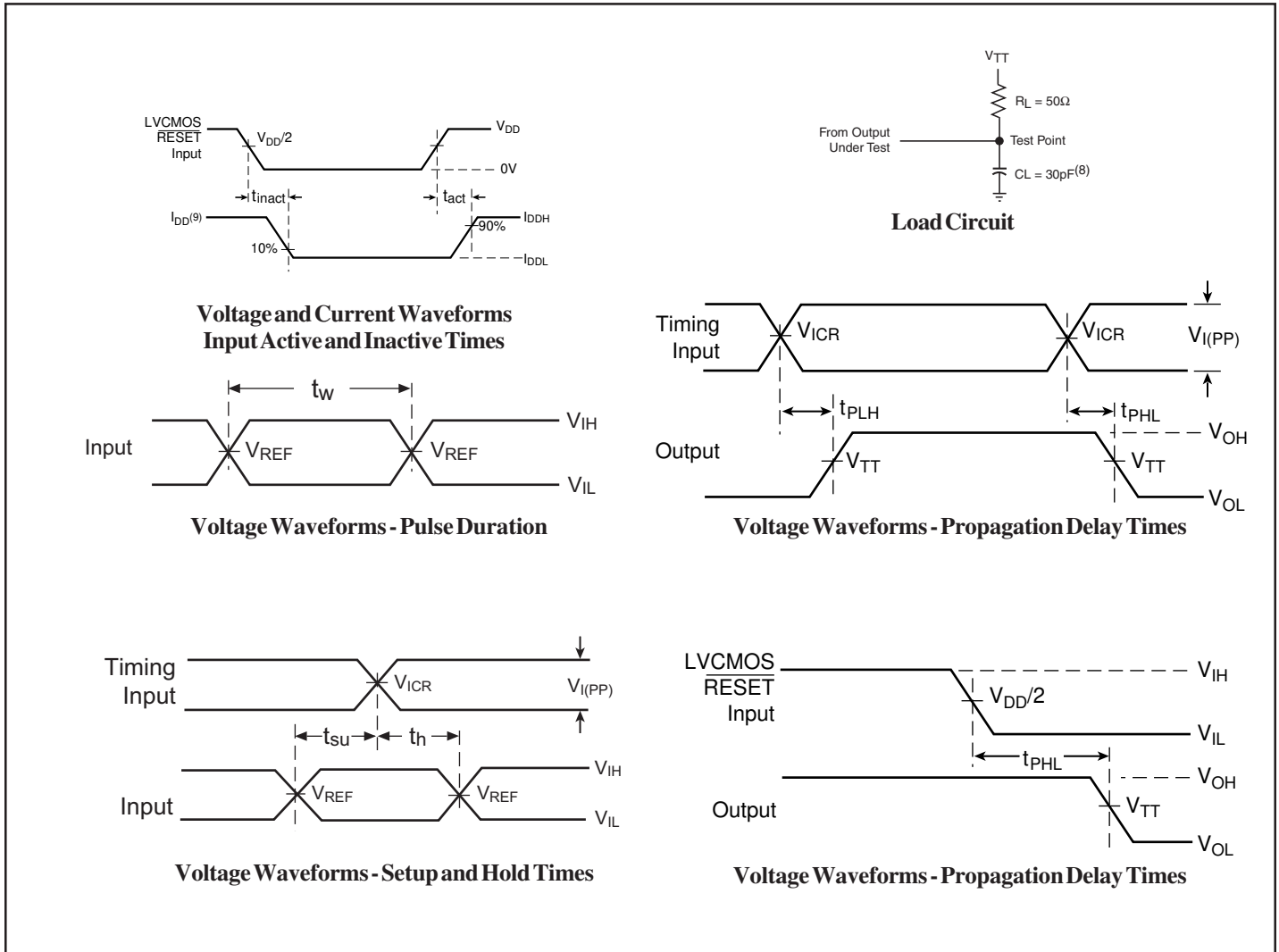

Parameter Measurement Information ($V_{DD} = 2.5V \pm 0.2V$)

Notes:

8. C_L includes probe and jig capacitance.
9. I_{DD} tested with clock and data inputs held at V_{DD} or GND, and $I_O = 0mA$.
10. All input pulses are supplied by generators having the following characteristics:
PRR ≤ 10 MHz, $Z_O = 50\Omega$. Input slew rate = $1V/ns \pm 20\%$ (unless otherwise specified).
11. The outputs are measured one at a time with one transition per measurement.
12. $V_{TT} = V_{REF} = V_{DDQ}/2$
13. $V_{IH} = V_{REF} + 350mV$ (ac voltage levels) for SSTL inputs. $V_{IH} = V_{DD}$ for LVC MOS input.
14. $V_{IL} = V_{REF} + 350mV$ (ac voltage levels) for SSTL inputs. $V_{IL} = GND$ for LVC MOS input.
15. t_{PLH} and t_{PHL} are the same as t_{pd} .

48-Pin TSSOP Package (A)

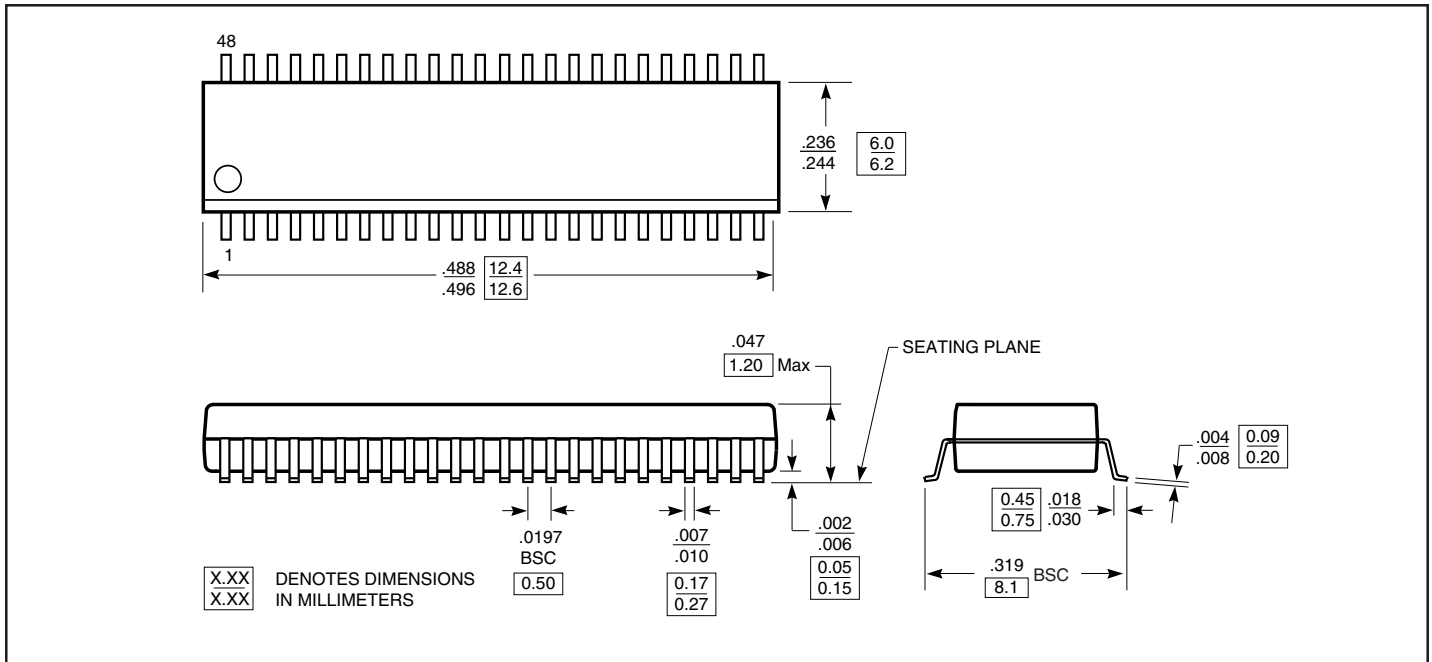

Ordering Information

Ordering Code	Package Type	Operating Range
PI74SSTV16857A	48-Pin, 240-mil TSSOP	0°C to 70°C
PI74SSTV16857AE	48-Pin, 240-mil TSSOP (Pb-Free)	0°C to 70°C