



Chipsmall Limited consists of a professional team with an average of over 10 year of expertise in the distribution of electronic components. Based in Hongkong, we have already established firm and mutual-benefit business relationships with customers from,Europe,America and south Asia,supplying obsolete and hard-to-find components to meet their specific needs.

With the principle of “Quality Parts,Customers Priority,Honest Operation,and Considerate Service”,our business mainly focus on the distribution of electronic components. Line cards we deal with include Microchip,ALPS,ROHM,Xilinx,Pulse,ON,Everlight and Freescale. Main products comprise IC,Modules,Potentiometer,IC Socket,Relay,Connector.Our parts cover such applications as commercial,industrial, and automotives areas.

We are looking forward to setting up business relationship with you and hope to provide you with the best service and solution. Let us make a better world for our industry!



## Contact us

Tel: +86-755-8981 8866 Fax: +86-755-8427 6832

Email & Skype: info@chipsmall.com Web: www.chipsmall.com

Address: A1208, Overseas Decoration Building, #122 Zhenhua RD., Futian, Shenzhen, China



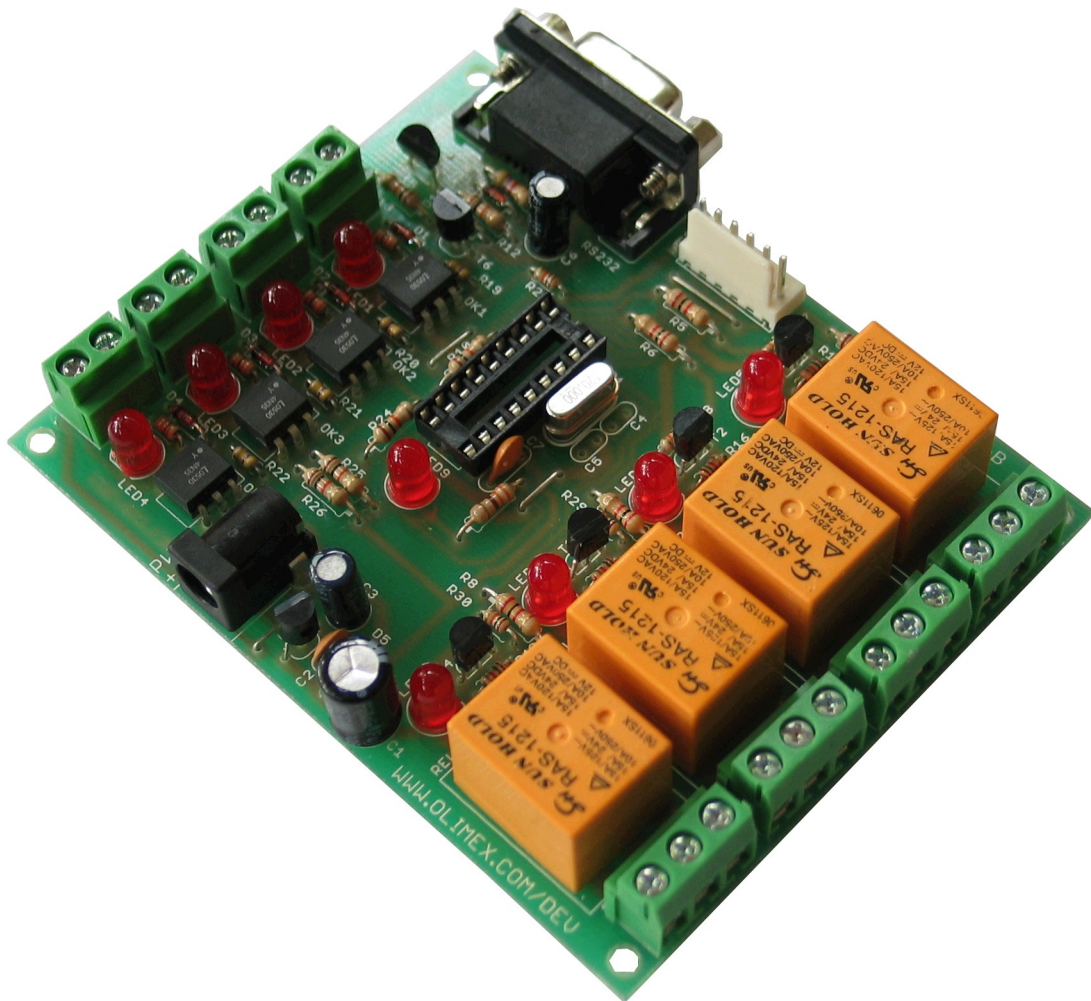

## PIC-IO development board User's Manual

Rev.C, October 2012



Copyright(c) 2012, OLIMEX Ltd, All rights reserved

All boards produced by Olimex are ROHS compliant

## INTRODUCTION:

PIC-IO board was designed as simple platform which to allow control of appliances and devices with PIC, the idea was to build something like tiny PLC controller which is possible to program in C or assembler instead of the weird PLC relay language.

Let's see what we have on board:

Four High voltage/ High Current relays – with NO-NC-COM contacts available on terminal block. The relay switching current is rated: 15A/125VAC, 10A/250VAC, 15A/24VDC. Note that these relays are good for switching resistive loads, but if you have to commutate inductive loads the relays will wear off quickly due to the sparking when disconnect the inductive loads (like motors).

Each relay have status LED associated with it so you can easy see which relay is in ON and which in OFF state.

O1 is connected to RA3 CMP1 and PIC CCP module can be used to generate ON/OFF pulses.  
O2-O3-O4 are connected to RA2-RA1-RA0.

Four opto-isolated inputs will allow to detect voltages in range +5-24VDC. Opto-couplers are fast and switch On/Off for 10 uS, so quick signals could be detected.

**!NOTE for owners of MOD-IO prior to revision C1: the above information is correct only for the opto-isolated couplers – the board is capable to handle up to 22VDC for them. You need to swap R1, R2, R3, R4 - 330R resistors with 470R ones be able to use 24VDC! This has been fixed in the latest revision as seen in the schematics.**

I1 is connected to RA4 and is good for counting as this pin is connected to PIC T0CKI.

I2 is connected to RB0 which is INT and generates interrupts.

I3 is connected to CCP1 and is good for pulse width measurement.

I4 is connected to RB4.

The inputs have status LEDs so easy could be seen which input have voltage. Note that the optocouplers inverse the levels i.e. when on the input have +5V the PIC pin will read “0” and vice versa.

Status LED is connected to RB5.

PIC-IO have RS232 connector, but the driver is made by tricky level shifter which uses the other side RS232 negative levels to generate the PIC-IO levels, so on the other side you must

have real RS232 driver (like PC) if you try to connect two PIC-IO boards by RS232 the connection will fail as no one of the boards will generate the negative levels.

The on-board ICSP connector allow you to program the PIC on the board without pulling it of the socket, by ICSP programmer like PIC-MCP, PIC-MCP-USB, PIC-PG1, PIC-PG2, PIC-PG3, PIC-PG4 or to program and debug it with PIC-ICD2, PIC-ICD2-POCKET or PIC-ICD2-TINY. **IMPORTANT:** all programmers provide power supply through ICSP connector during the programming PIC-IO should not be powered via the external power jack!

The power supply circuit have protection diode for reverse connection. The positive point is the internal pin of the power jack. The input voltage could be in range 12–14V DC.

The oscillator circuit is made with 20 Mhz crystal oscillator, so you can run your PIC at maximum performance.

The RESET is connected with 10K to +5V and allow safe use of PIC-ICD2 or PIC-MCP programming.

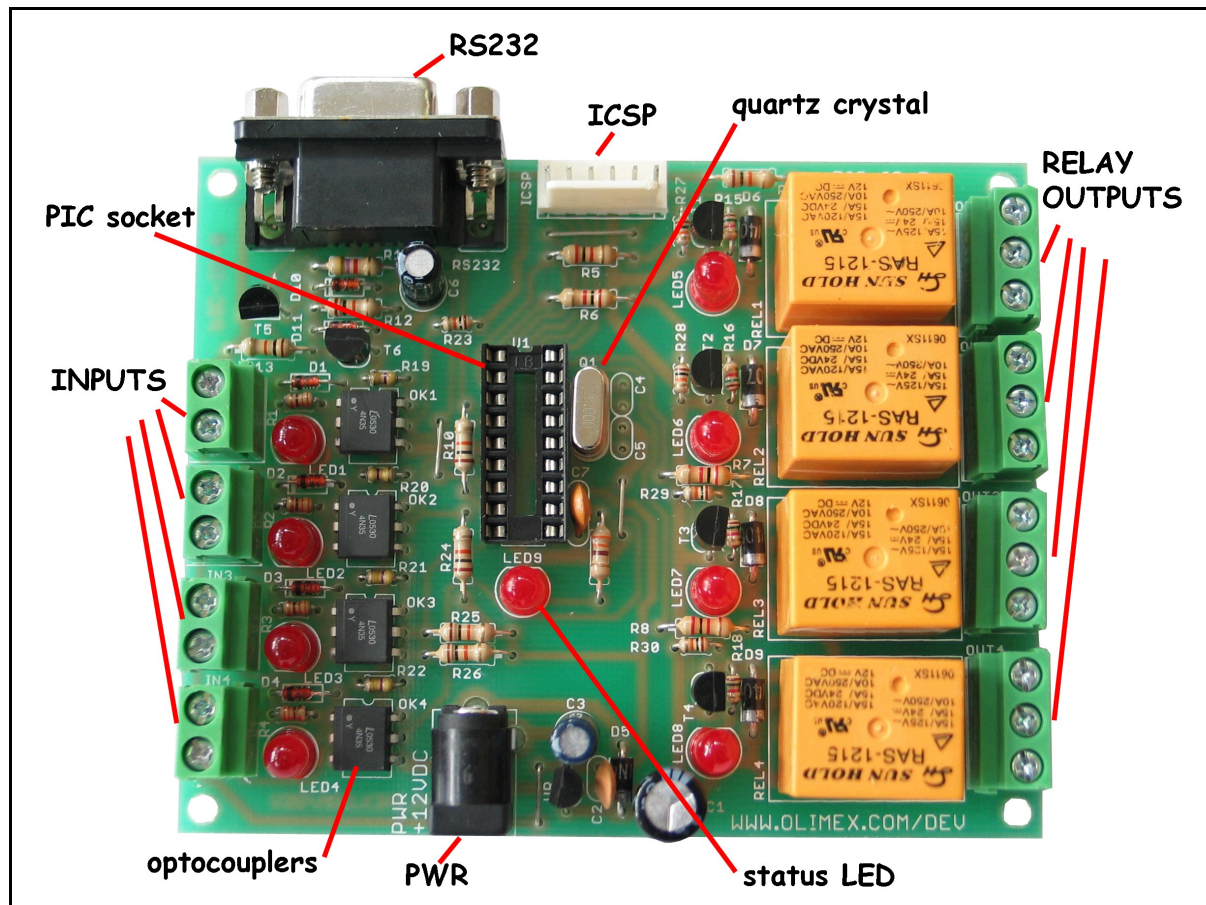
**FEATURES:**

- ICSP/ICD connector for programming and debugging
- RS232 interface
- DIL18 socket
- Quartz crystal 20Mhz
- LED to RB5 through jumper
- Four opto-isolated inputs with status LEDs
- Four Relays 10A/250VAC with status LEDs
- Power plug-in jack, accept AC and DC input
- Four mounting holes 3,3 mm (0,13")
- FR-4, 1.5 mm (0,062"), green soldermask, white silkscreen component print
- Dimensions 100x80 mm (3,9x3,15")

# HARDWARE:

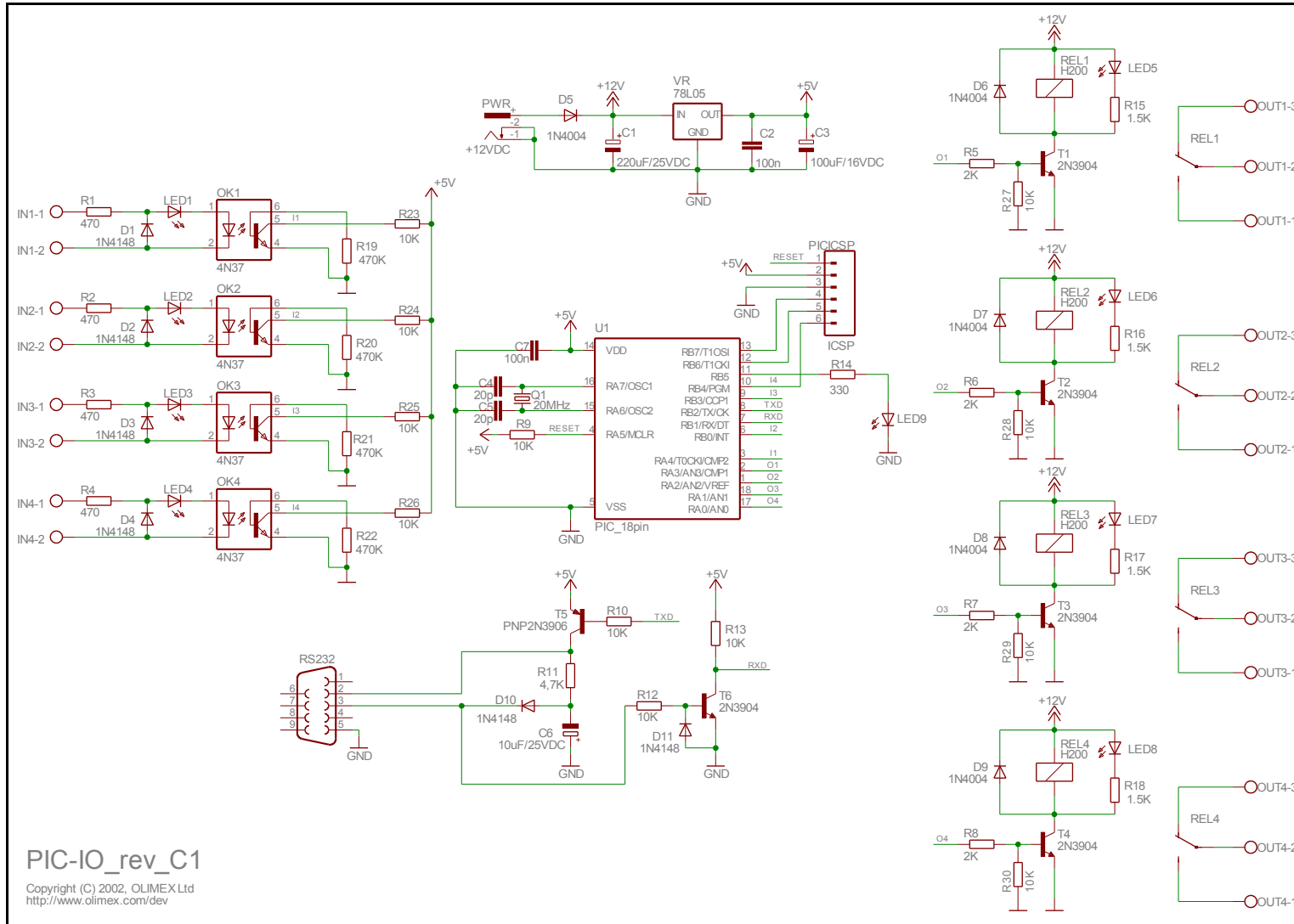

## SOFTWARE:

### **DEMO1: PIC16F628-I/P CONTROL SOFTWARE**

This is demo code, which allow control of the PIC-IO inputs/outputs via PC with Hyper terminal.

Connect PIC-IO RS232 with cable to your PC and run Hyper terminal with these settings: 9600,8,N,1,NONE. When you apply power this will be seen on the Hyper terminal window:

```
*****  
* PIC-IO CONTROL      *  
* (C) 2007, OLIMEX Ltd*  
*****  
>_
```

To read the inputs in binary format type “r”, PIC-IO will respond with something like:

```
%0000      if all inputs are 0 or  
%1111      if all inputs are 1 (i.e. +5V is applied)  
the inputs are with right less significant bit i.e. the order is: I4 I3 I2 I1
```

To read the inputs in HEX format type “R”, PIC-IO will respond with something like:

```
$0          if all inputs are 0 or  
$F          if all inputs are 1
```

To change the outputs type “w0101”, this will switch on relay 1 and relay 3 and will switch off relay 2 and relay 4.

If you want to use HEX value you can write “W5” for instance which will switch on relay 4 and relay 1 and will switch off relay 2 and relay 3.

Any other commands will not be recognized and PIC-IO will respond with “ERR”

**ORDER CODE:**

PIC-PIO – assembled and tested (no kit, no soldering required)

How to order?

You can order directly from us or from any of our distributors.

Check our web <https://www.olimex.com> for more info.

**Revision history:**

- REV.A - created June 2007
- REV.B - added info about the maximum voltage possible on the opto-couplers, 22VDC by default
- REV.C - changed schematic with the latest one, revision C1 of the board has adjusted resistors on the relay inputs (330R were replaced with 470R); added a note about differences in different revisions; updated disclaimer; added support and warranty info



## DISCLAIMER

---

© 2012 Olimex Ltd. Olimex®, logo and combinations thereof, are registered trademarks of Olimex Ltd. Other product names may be trademarks of others and the rights belong to their respective owners.

**The information in this document is provided in connection with Olimex products. No license, express or implied or otherwise, to any intellectual property right is granted by this document or in connection with the sale of Olimex products.**

The Hardware project is released under the Creative Commons Attribution-Share Alike 3.0 United States License. You may reproduce it for both your own personal use, and for commercial use. You will have to provide a link to the original creator of the project <https://www.olimex.com> on any documentation or website.

You may also modify the files, but you must then release them as well under the same terms. Credit can be attributed through a link to the creator website: <https://www.olimex.com>

The software is released under GPL.

It is possible that the pictures in this manual differ from the latest revision of the board.

The product described in this document is subject to continuous development and improvements. All particulars of the product and its use contained in this document are given by OLIMEX in good faith. However all warranties implied or expressed including but not limited to implied warranties of merchantability or fitness for purpose are excluded. This document is intended only to assist the reader in the use of the product. OLIMEX Ltd. shall not be liable for any loss or damage arising from the use of any information in this document or any error or omission in such information or any incorrect use of the product.

This evaluation board/kit is intended for use for engineering development, demonstration, or evaluation purposes only and is not considered by OLIMEX to be a finished end-product fit for general consumer use. Persons handling the product must have electronics training and observe good engineering practice standards. As such, the goods being provided are not intended to be complete in terms of required design-, marketing-, and/or manufacturing-related protective considerations, including product safety and environmental measures typically found in end products that incorporate such semiconductor components or circuit boards.

Olimex currently deals with a variety of customers for products, and therefore our arrangement with the user is not exclusive. Olimex assumes no liability for applications assistance, customer product design, software performance, or infringement of patents or services described herein.

**THERE IS NO WARRANTY FOR THE DESIGN MATERIALS AND THE COMPONENTS USED TO CREATE PIC-IO. THEY ARE CONSIDERED SUITABLE ONLY FOR PIC-IO.**

## Product support

---

For product support, hardware information and error reports mail to: [support@olimex.com](mailto:support@olimex.com). Note that we are primarily a hardware company and our software support is limited.

Please consider reading the paragraph below about the warranty of Olimex products.

### Warranty and returns:

Our boards have lifetime warranty against manufacturing defects and components.

During development work it is not unlikely that you can burn your programmer or development board. This is normal, we also do development work and we have damaged A LOT of programmers and boards during our daily job so we know how it works. If our board/programmer has worked fine then stopped, please check if you didn't apply over voltage by mistake, or shorted something in your target board where the programmer was connected etc. Sometimes boards might get damaged by ESD shock voltage or if you spill coffee on them during your work when they are powered.

Please note that warranty do not cover problems caused by improper use, shorts, over-voltages, ESD shock etc.

**If the board has warranty label it should be not broken. Broken labels void the warranty, same applies for boards modified by the customer, for instance soldering additional components or removing components - such boards will be not be a subject of our warranty.**

If you are positive that the problem is due to manufacturing defect or component you can return the board back to us for inspection.

When we receive the board we will check and if the problem is caused due to our fault and we will repair/replace the faulty hardware free of charge, otherwise we can quote price of the repair.

Note that all shippings back and forth have to be covered by the customer. Before you ship anything back you need to ask for RMA. When you ship back please attach to it your shipping address, phone, e-mail, RMA# and brief description of the problem. All boards should be sent back in antistatic package and well packed to prevent damages during the transport.