



Chipsmall Limited consists of a professional team with an average of over 10 year of expertise in the distribution of electronic components. Based in Hongkong, we have already established firm and mutual-benefit business relationships with customers from,Europe,America and south Asia,supplying obsolete and hard-to-find components to meet their specific needs.

With the principle of “Quality Parts,Customers Priority,Honest Operation,and Considerate Service”,our business mainly focus on the distribution of electronic components. Line cards we deal with include Microchip,ALPS,ROHM,Xilinx,Pulse,ON,Everlight and Freescale. Main products comprise IC,Modules,Potentiometer,IC Socket,Relay,Connector.Our parts cover such applications as commercial,industrial, and automotives areas.

We are looking forward to setting up business relationship with you and hope to provide you with the best service and solution. Let us make a better world for our industry!



Contact us

Tel: +86-755-8981 8866 Fax: +86-755-8427 6832

Email & Skype: info@chipsmall.com Web: www.chipsmall.com

Address: A1208, Overseas Decoration Building, #122 Zhenhua RD., Futian, Shenzhen, China



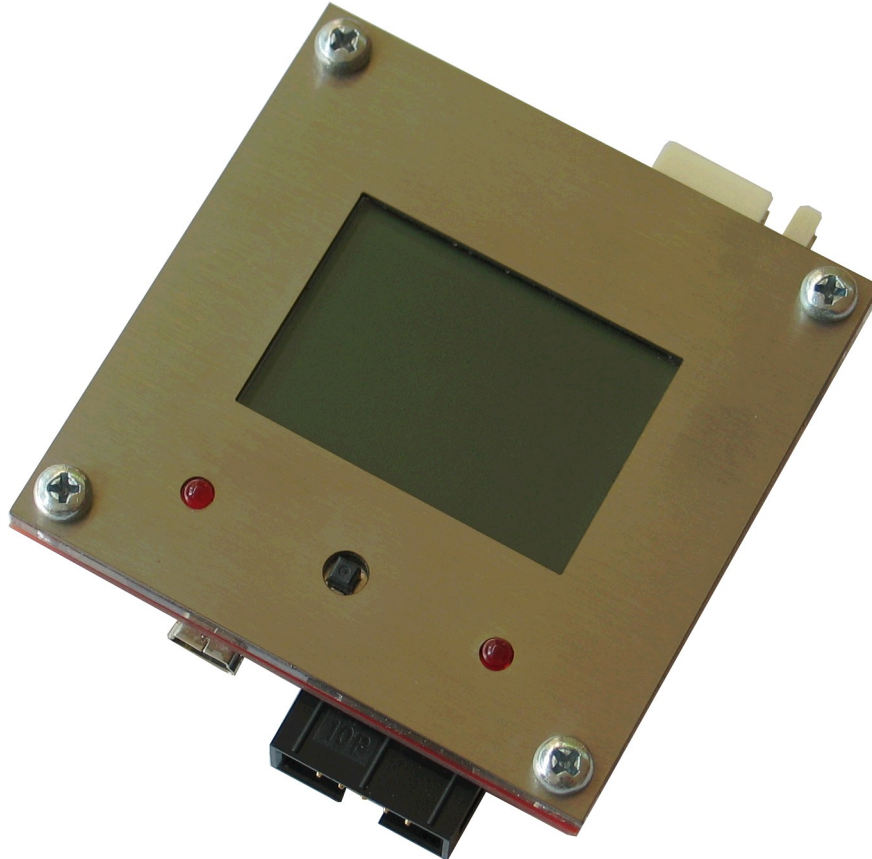

PIC-LCD-3310 development board _____
Users Manual

Rev.B, January 2011
Copyright(c) 2011, OLIMEX Ltd, All rights reserved

INTRODUCTION:

PIC-LCD-3310 is development board with PIC18F67J50, NOKIA 3310 BW 84x48 pixels LCD, two LEDs and a joystick. The board has SD-MMC connector, mini USM and all PIC ports are available on two extension connectors. The board have 3-axis accelerometer MMA7260 (seen on the picture). It's perfect for motion data-logging/analyze, 3-d mouses etc application.

BOARD FEATURES:

- MCU: PIC18F67J50 with 128KB Flash memory, 3904B SRAM, 10-bit 8-channel ADC module, PWM, SPI, I2C, EUSART, 2 Analog comparators and 8/16-bit Timer/Counters
- ICSP connector for PIC-ICD2/PIC-ICD2-POCKET debugger/programmer or PIC-PGx programmers
- LCD NOKIA 3310 black/white 84x48 pixels
- Two status LEDs
- Joystick with LEFT, RIGHT, UP, DOWN and CENTER action
- mini USB connector
- SD/MMC card connector
- MMA7260 accelerometer
- Extension connectors for all PIC ports
- +(4.5-6.0) battery connector
- PCB: FR-4, 1.5 mm (0,062"), soldermask, silkscreen component print
- Dimensions 65x65 mm (2.56 x 2.56")

ELECTROSTATIC WARNING:

The PIC-LCD3310 board is shipped in protective anti-static packaging. The board must not be subject to high electrostatic potentials. General practice for working with static sensitive devices should be applied when working with this board.

BOARD USE REQUIREMENTS:

Cables: 1.8 meter USB mini cable to connect to PC. Other cables might be required in case of other programming/debugging tools.

Hardware: Programmer/Debugger - **PIC-ICD2, PIC-ICD2-POCKET** or other compatible programming/debugging tool.

!!!Warning!!! When you want to program this microcontroller with PIC-ICD2, PIC-ICD2-POCKET or PIC-ICD2-TINY, before connecting the programmer to your target board, you should first connect the programmer to your computer and open MPLAB. There, first from menu Configure - Select Device - choose the microcontroller you are about to program, then from menu Programmer - Select Programmer

- choose MPLAB ICD 2, wait while MPLAB is downloading operation system, and after ICD2 is connected - check in menu Programmer - Settings - Power - there is option - Power target circuit from MPLAB ICD 2 - this option should be forbidden, you could not select it. Now it is safe to connect the programmer to your target board.

Software: **MPLAB IDE (latest version), MPLAB C18 Compiler** or any other compatible development/programming software.

PROCESSOR FEATURES:

PIC-LCD3310 board use MCU **PIC18F67J50** from Microchip with these features:

- USB V2.0 Compliant SIE
- Low Speed (1.5 Mb/s) and Full Speed (12 Mb/s)
- Supports Control, Interrupt, Isochronous and

Bulk Transfers

- Supports up to 32 Endpoints (16 bidirectional)
- Supports up to 32 Endpoints (16 bidirectional)
- 3.9-Kbyte Dual Access RAM for USB
- On-Chip USB Transceiver
- High-Precision PLL for USB
- Two External Clock modes, up to 48 MHz
- Internal 31 kHz Oscillator, Tunable Internal

Oscillator, 31 kHz to 8 MHz

- Secondary Oscillator using Timer1 @ 32 kHz
- Fail-Safe Clock Monitor:
 - o Allows for safe shutdown if any clock stops
- High-Current Sink/Source 25 mA/25mA

(PORTB and PORTC)

- Four Programmable External Interrupts
- Four Input Change Interrupts
- Two Capture/Compare/PWM (CCP) modules
- Three Enhanced Capture/Compare/PWM (ECCP)

modules:

- o One, two or four PWM outputs
- o Selectable polarity
- o Programmable dead time
- o Auto-shutdown and auto-restart

- Two Master Synchronous Serial Port (MSSP)

modules supporting 3-Wire SPI (all 4 modes) and

I2C. Master and Slave modes

- 8-Bit Parallel Master Port/Enhanced Parallel

Slave Port with 16 Address Lines

- Dual Analog Comparators with Input Multiplexing
- 10-Bit, up to 12-Channel Analog-to-Digital (A/D)

Converter module:

- o Auto-acquisition capability
- o Conversion available during Sleep

- Two Enhanced USART modules:
 - o Supports RS-485, RS-232 and LIN 1.2
 - o Auto-wake-up on Start bit
 - o Auto-Baud Detect

- Address Capability of up to 2 Mbytes
- 8-Bit or 16-Bit Interface
- 12-Bit, 16-Bit and 20-Bit Addressing modes
- 5.5V Tolerant Inputs (digital-only pins)
- Low-Power, High-Speed CMOS Flash Technology
- C Compiler Optimized Architecture for

Re-Entrant Code

- Power Management Features:
 - o Run: CPU on, peripherals on

- Idle: CPU off, peripherals on
 - Sleep: CPU off, peripherals off
- Priority Levels for Interrupts
- Self-Programmable under Software Control
- 8 x 8 Single-Cycle Hardware Multiplier
- Extended Watchdog Timer (WDT):
 - Programmable period from 4 ms to 131s
- Single-Supply In-Circuit Serial Programming.
(ICSP™) via Two Pins
- In-Circuit Debug (ICD) with 3 Breakpoints via
Two Pins
- Operating Voltage Range of 2.0V to 3.6V
- On-Chip 2.5V Regulator
- Flash Program Memory of 10000 Erase/Write
Cycles and 20-Year Data Retention

BLOCK DIAGRAM:

FIGURE 1-1: PIC18F6XJ5X (64-PIN) BLOCK DIAGRAM

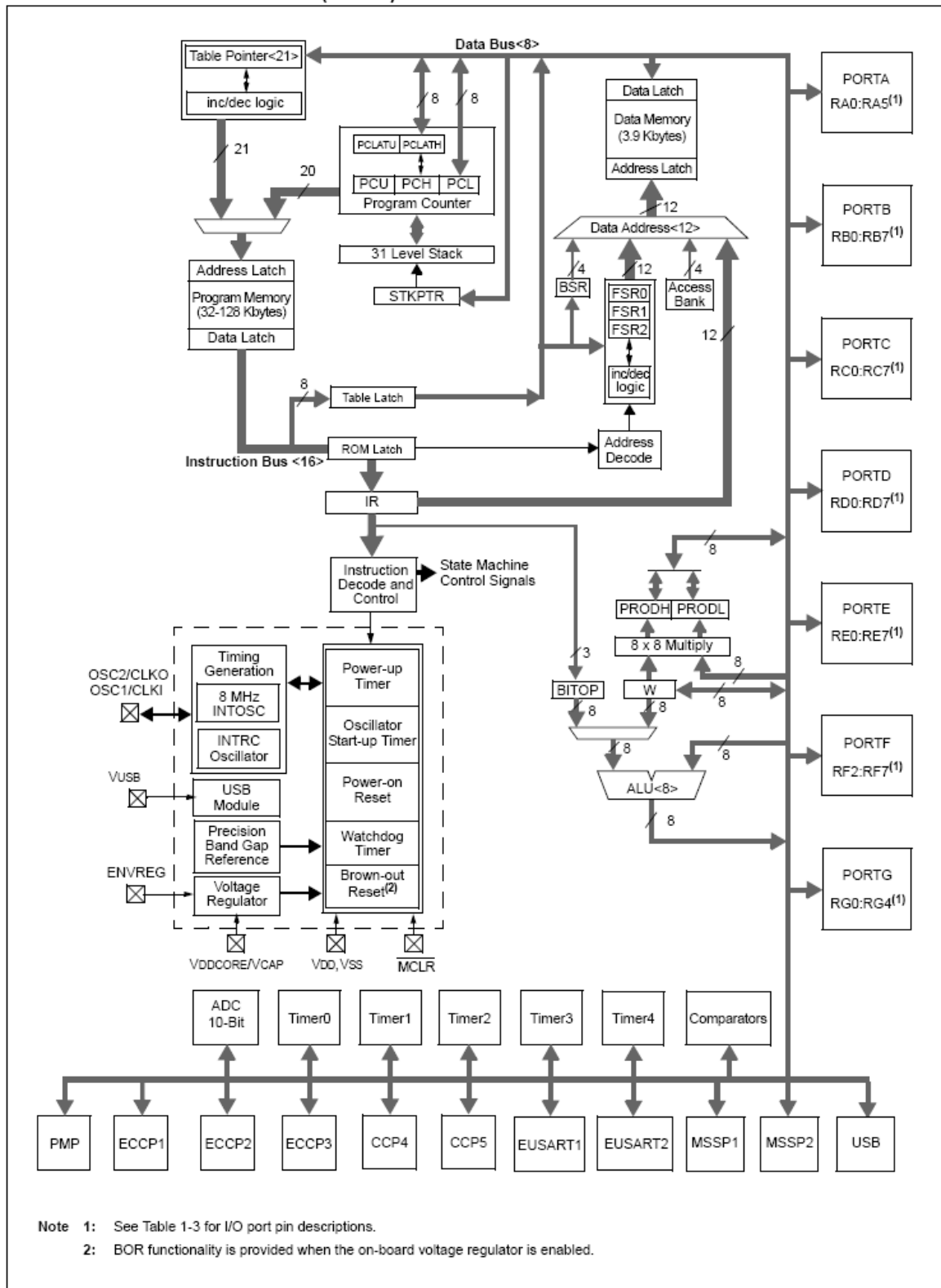

MEMORY MAP:

FIGURE 5-1: MEMORY MAPS FOR PIC18F87J50 FAMILY DEVICES

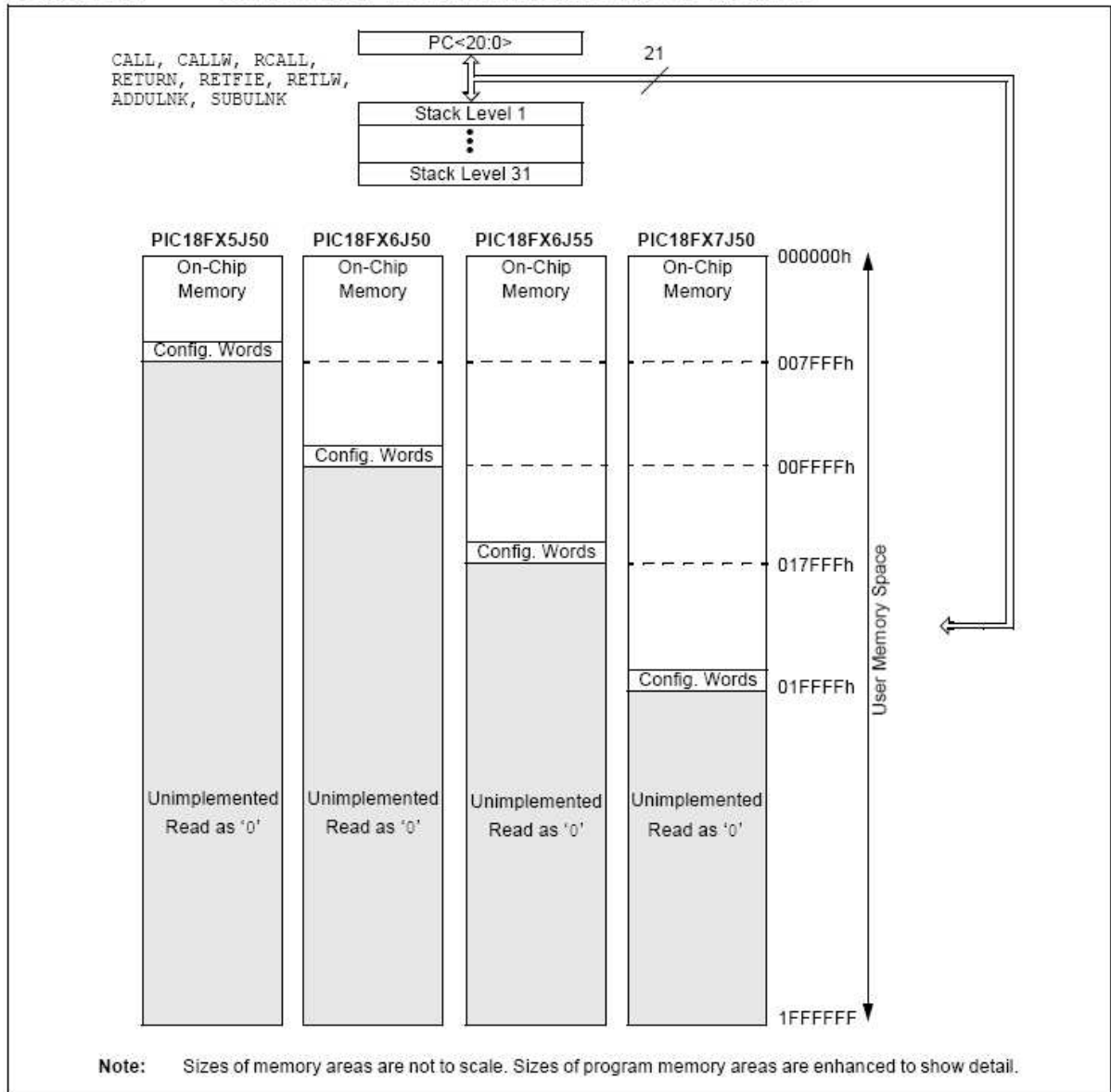

SCHEMATIC:

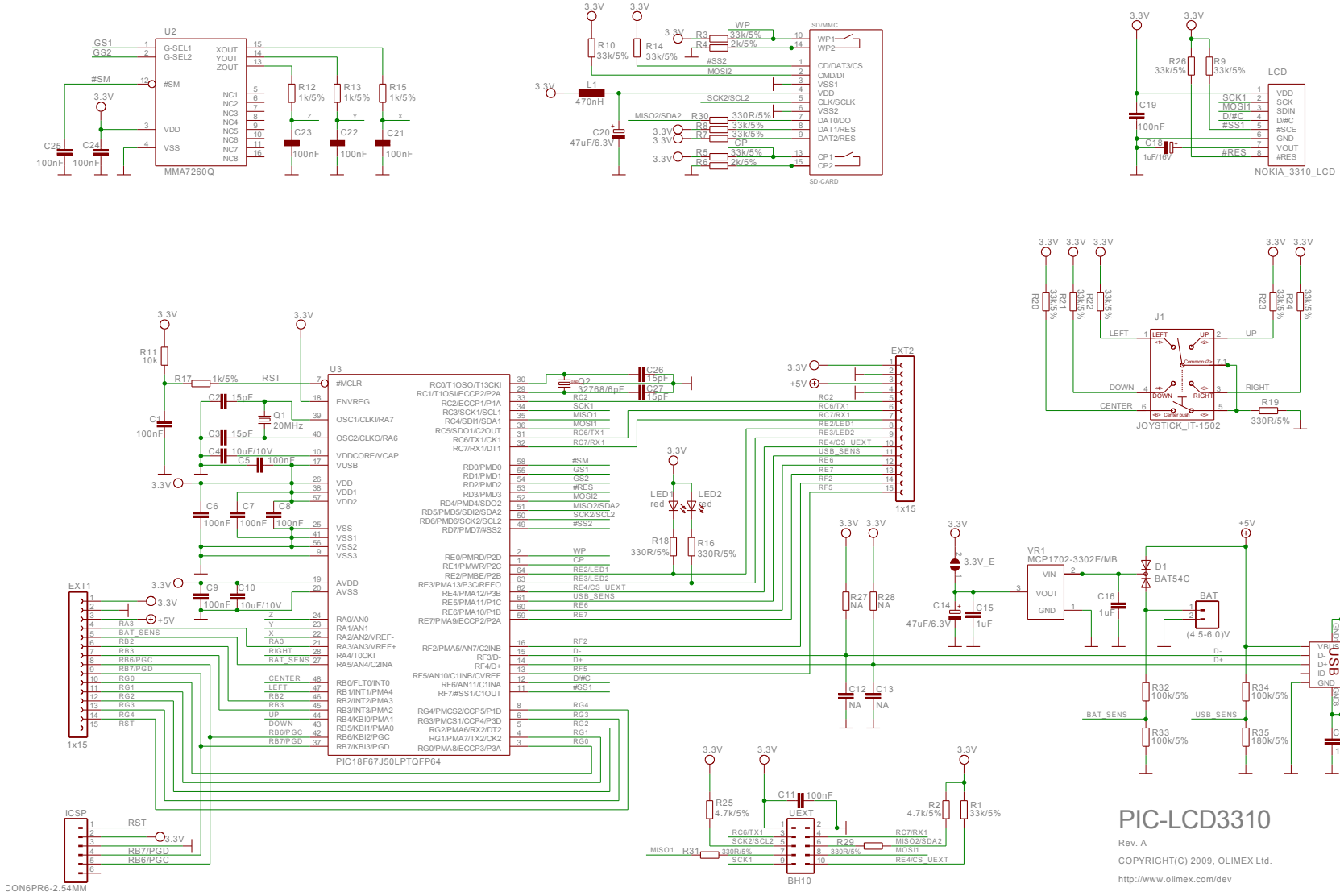

PIC-LCD3310
 Rev. A
 COPYRIGHT(C) 2009, OLIMEX LTD.
<http://www.olimex.com/dev>

BOARD LAYOUT:

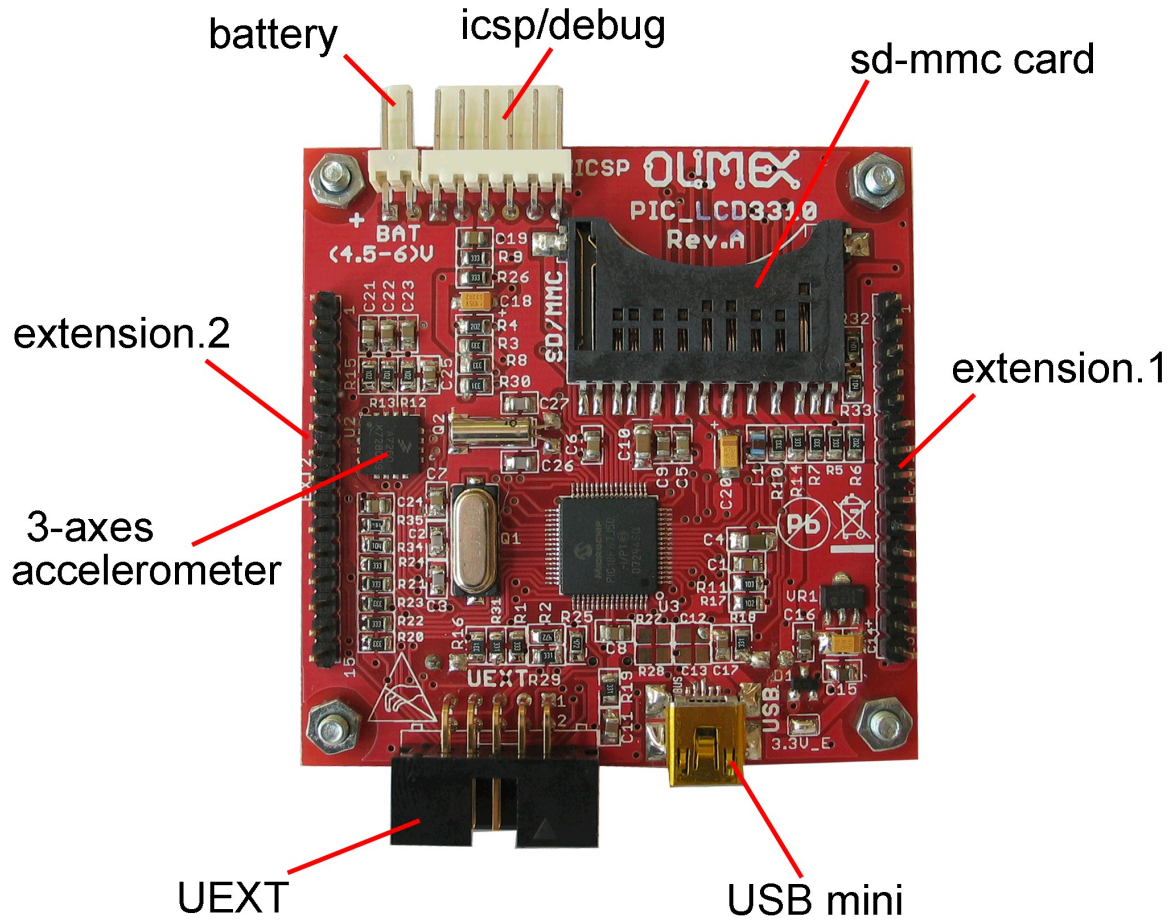

POWER SUPPLY CIRCUIT:

PIC-LCD-3310 takes power from a battery $+ (4.5-6)VDC$ or from the mini USB port.

The board power consumption at 5-6VDC the consumption is about 20mA.

RESET CIRCUIT:

PIC-LCD-3310 doesn't have reset circuit. The MCU resets if you apply logical zero (GND) to EXT1.pin 15 or to ICSP.pin 1.

CLOCK CIRCUIT:

Quartz crystal 20 MHz is connected to PIC18F67J50 pin 39 clock in (OSC1/CLKI/RA7) and pin 40 clock out (OSC2/CLKO/RA6).

Quartz crystal 32.768 kHz is connected to **PIC18F67J50** pin 29 (RC1/T1OSI/ECCP2/P2A) and pin 30 (RC0/T1OSO/T13CKI) and supplies the Timer1 which could function as a Real Time Clock.

JUMPER DESCRIPTION:

3.3V_E



enables 3.3 V power supply for the **PIC18F67J50** and all other devices.
Default state is closed.

INPUT/OUTPUT:

Status red LED with name **LED1** connected to PIC18F67J50 pin 64 (RE2/PMBE/P2B).

Status red LED with name **LED2** connected to PIC18F67J50 pin 63 (RE3/PMA13/P3C/REFO).

Joystick with name **J1** and with five positions – left, right, up, down and center.

Accelerometer MMA7260.

NOKIA-LCD 3310.

EXTERNAL CONNECTORS DESCRIPTION:

ICSP:

Pin #	Signal Name
1	RST
2	+3.3V
3	GND
4	RB7/PGD
5	RB6/PGC
6	NC

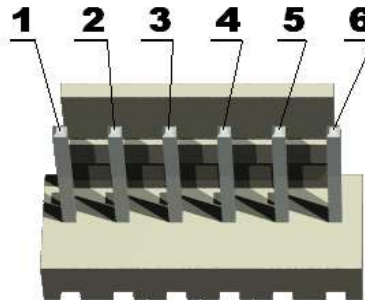

PGD I/O **Program Data.** Serial data for programming.

PGC Input **Program Clock.** Clock used for transferring the serial data (output from ICSP, input for the MCU).

EXT1:

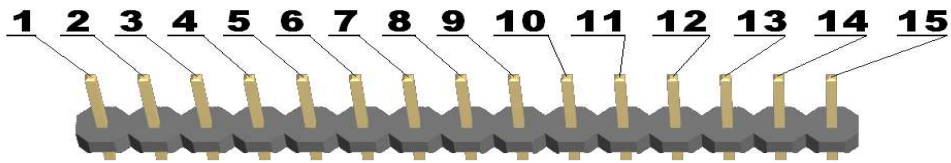

Pin #	Signal Name	Pin #	Signal Name
1	+3.3V	2	GND
3	+5V	4	RA3
5	BAT_SENS	6	RB2
7	RB3	8	RB6/PGC
9	RB7/PGD	10	RG0
11	RG1	12	RG2
13	RG3	14	RG4
15	RST		

BAT_SENS Input **Battery Power Supply.** This signal tells the processor that it is powered by the battery.

PGD I/O **Program Data.** Serial data for programming.

PGC Input **Program Clock.** Clock used for transferring the serial data (output from ICSP, input for the MCU).

EXT2:

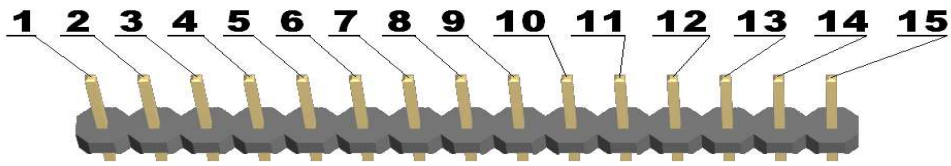

Pin #	Signal Name	Pin #	Signal Name
1	+3.3V	2	GND
3	+5V	4	GND
5	RC2	6	RC6/TX1
7	RC7/RX1	8	RE2/LED1
9	RE3/LED2	10	RE4/CS_UEXT
11	USB_SENS	12	RE6
13	RE7	14	RF2
15	RF5		

TX1 Output **Transmit Data 1.** This is the output data line for the UART1.
RX1 Input **Receive Data 1.** This is the input data line for the UART1.
LED1 Input This signal controls LED1.
LED2 Input This signal controls LED2.
USB_SENS Input **USB power supply.** This signal tells the processor that it receives power through the mini USB port.

UEXT:

Pin #	Signal Name
1	+3.3V
2	GND
3	RC6/TX1
4	RC7/RX1
5	SCK2/SCL2
6	MISO2/SDA2
7	MISO1
8	MOSI1
9	SCK1
10	RE4/CS_UEXT

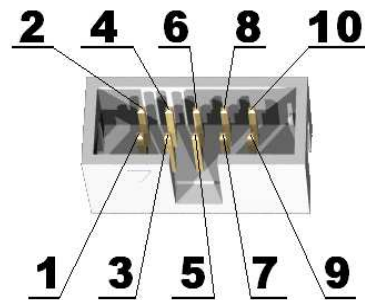

TX1 Output **Transmit Data 1.** This is the output data line for the UART1.

RX1 Input **Receive Data 1.** This is the input data line for the UART1.

SCK2/SCL2 I/O **Serial (Synchronization) Clock 2.** This is the synchronization clock for the data transfer. When the pin is used for communication through SPI2, the name of the signal is SCK2 and when the communication is through I2C, the name of the signal is SCL2. This could be either input or output depending on whether the MCU is master or slave.

MISO2/SDA2 I/O **Master In Slave Out 2/Serial Data 2.** When this pin is used for communication through SPI2 interface, its name is MISO and if the communication is through I2C interface its name is SDA. In case of SPI this could be either input (MCU is master) or output (MCU is slave). In case of I2C this could be used as both input and output depending on the data flow direction.

MOSI1 I/O **Master Out Slave In 1.** This pin could be used for communication through SPI1 interface, in which case this is either data output from the MCU (when it is master) or data input for the MCU (when it is slave).

SCK1 I/O **Serial (Synchronization) Clock 1.** This is the synchronization clock for the data transfer. If this pin is used for communication through SPI1, it could be either input or output depending on whether the MCU is master or slave.

BAT:

Pin #	Signal Name
1	+(4.5-6.0)VDC
2	GND

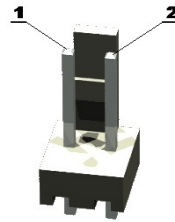

Mini USB:

Pin #	Signal Name
1	+5V
2	D-
3	D+
4	NC
5	GND

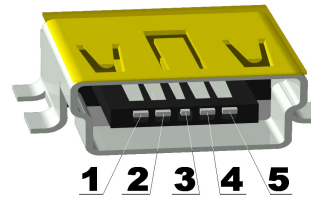

D- and D+ both form differential input or output depending on the direction of the data flow.

SD/MMC card slot:

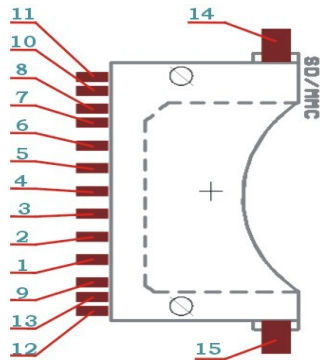

Pin #	Signal Name	Pin #	Signal Name
1	#SS2	2	MOSI2
3	GND	4	VDD (+3.3V)
5	SCK2/SCL2	6	GND
7	MISO2/SDA2	8	+3.3V
9	+3.3V	10	WP
11	-	12	-
13	CP	14	GND
15	GND		

#SS2 Output **Slave Select 2.** This signal is Slave Select for the SPI2 interface. As the MSU is master, this signal is output from it.

MOSI2 Output **Master Out Slave In 2.** When the access to the memory is via SPI2 interface, this is data output from the MCU (which is master) and input for the memory card (which is slave).

SCK2/SCL2 Output **Serial (Synchronization) Clock 2.** This is the synchronization clock for the data transfer. When the access to the memory card is via SPI2, the name of the signal is SCK2 and when the access is via I2C, the name of the signal is SCL2.

MISO2/SDA2 I/O **Master In Slave Out 2/Serial Data 2.** When the access to the memory card is via SPI2 interface, this is data input for the MCU(which is master) and data output from the memory card (which is slave). If the access to the memory card is via I2C this is both data input and output to the MCU.

WP Input **Write Protect.** This signal is input for the MCU.

CP Input **Card Present.** This signal is input for the MCU.

MECHANICAL DIMENSIONS:

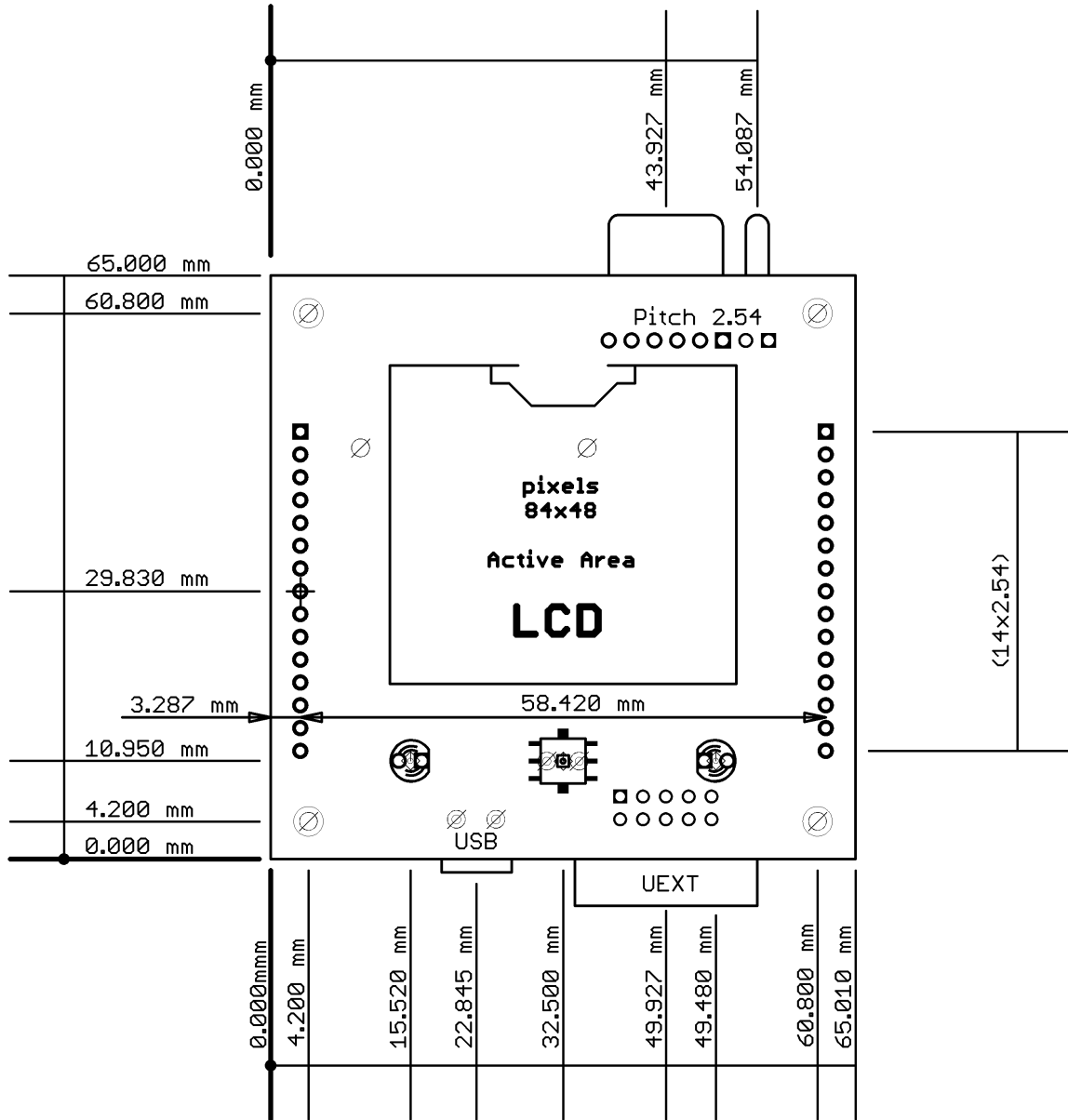

AVAILABLE DEMO SOFTWARE:

- [Test demo code](#) (C source and HEX)
- [GPS compass](#) with MOD-GPS and PIC-LCD3310 (C source and HEX)

You could find information about PIC-LCD-3310 demo software at
www.olimex.com/dev.

ORDER CODE:

PIC-LCD-3310 – assembled and tested (no kit, no soldering required)

How to order?

You can order to us directly or by any of our distributors.

Check our web www.olimex.com/dev for more info.



All boards produced by Olimex are RoHS compliant

Revision history:

REV.A	- created	July 2008
REV. B	- created	January 2011 – added more detailed mechanical dimensions, latest revision of the scheme and page number.

Disclaimer:

© 2011 Olimex Ltd. All rights reserved. Olimex®, logo and combinations thereof, are registered trademarks of Olimex Ltd. Other terms and product names may be trademarks of others.

The information in this document is provided in connection with Olimex products. No license, express or implied or otherwise, to any intellectual property right is granted by this document or in connection with the sale of Olimex products.

Neither the whole nor any part of the information contained in or the product described in this document may be adapted or reproduced in any material from except with the prior written permission of the copyright holder.

The product described in this document is subject to continuous development and improvements. All particulars of the product and its use contained in this document are given by OLIMEX in good faith. However all warranties implied or expressed including but not limited to implied warranties of merchantability or fitness for purpose are excluded.

This document is intended only to assist the reader in the use of the product. OLIMEX Ltd. shall not be liable for any loss or damage arising from the use of any information in this document or any error or omission in such information or any incorrect use of the product.