



Chipsmall Limited consists of a professional team with an average of over 10 year of expertise in the distribution of electronic components. Based in Hongkong, we have already established firm and mutual-benefit business relationships with customers from,Europe,America and south Asia,supplying obsolete and hard-to-find components to meet their specific needs.

With the principle of “Quality Parts,Customers Priority,Honest Operation,and Considerate Service”,our business mainly focus on the distribution of electronic components. Line cards we deal with include Microchip,ALPS,ROHM,Xilinx,Pulse,ON,Everlight and Freescale. Main products comprise IC,Modules,Potentiometer,IC Socket,Relay,Connector.Our parts cover such applications as commercial,industrial, and automotives areas.

We are looking forward to setting up business relationship with you and hope to provide you with the best service and solution. Let us make a better world for our industry!



Contact us

Tel: +86-755-8981 8866 Fax: +86-755-8427 6832

Email & Skype: info@chipsmall.com Web: www.chipsmall.com

Address: A1208, Overseas Decoration Building, #122 Zhenhua RD., Futian, Shenzhen, China



PIC12LF1840T39A Product Brief

High-Performance RISC CPU:

- Only 49 Instructions to Learn:
 - All single-cycle instructions except branches
- Operating Speed:
 - DC – 32 MHz oscillator/clock input
 - DC – 125 ns instruction cycle
- Interrupt Capability with Automatic Context Saving
- 16-Level Deep Hardware Stack with Optional Overflow/Underflow Reset
- Direct, Indirect and Relative Addressing modes:
 - Two full 16-bit File Select Registers (FSRs)
 - FSRs can read program and data memory

Flexible Oscillator Structure:

- Precision 32 MHz Internal Oscillator Block:
 - Factory calibrated to $\pm 1\%$, typical
 - Software selectable frequencies range of 31 kHz to 32 MHz
- 31 kHz Low-Power Internal Oscillator
- Four Crystal modes up to 32 MHz
- Three External Clock modes up to 32 MHz
- 4x Phase Lock Loop (PLL)
- Fail-Safe Clock Monitor:
 - Allows for safe shutdown if peripheral clock stops
- Two-Speed Oscillator Start-up
- Reference Clock module:
 - Programmable clock output frequency and duty-cycle

Special Microcontroller Features:

- 1.8V-3.6V Operation
- Self-Reprogrammable under Software Control
- Power-on Reset (POR), Power-up Timer (PWRT) and Oscillator Start-up Timer (OST)
- Programmable Brown-out Reset (BOR)
- Extended Watchdog Timer (WDT)
- In-Circuit Serial Programming™ (ICSP™) via Two Pins
- In-Circuit Debug (ICD) via Two Pins
- Enhanced Low-Voltage Programming (LVP)
- Programmable Code Protection
- Power-Saving Sleep mode

Low-Power Features:

- Standby Current:
 - 30 nA @ 3.0V, typical, RF off
 - 530 nA @ 3.0V, typical, RF Sleep
- Operating Current:
 - 0.67 mA @ 8 MHz, 3.0V, RF off, typical
 - 9.67 mA @ 8 MHz, 3.0V, RF on at 0 dBm, typical
 - 15.67 mA @ 8 MHz, 3.0V, RF on at +10 dBm, typical
- Low-Power Watchdog Timer Current:
 - 500 nA @ 3.0V, typical

RF Transmitter:

- Fully Integrated Transmitter
- FSK Operation up to 100 kbps
- OOK Operation up to 10 kbps
- Frequency-Agile Operation in 310, 433, 868 and 915 MHz Bands
- +10 dBm or 0 dBm Configurable Output Power

Analog Features:

- Analog-to-Digital Converter (ADC) module:
 - 10-bit resolution, 4 channels
 - Conversion available during Sleep
- Analog Comparator module:
 - One rail-to-rail analog comparator
 - Power mode control
 - Software controllable hysteresis
- Voltage Reference module:
 - Fixed Voltage Reference (FVR) with 1.024V and 2.048V output levels
 - 5-bit rail-to-rail resistive DAC with positive and negative reference selection

Peripheral Features:

- 5 I/O Pins and 1 Input-only Pin:
 - High current sink/source 25 mA/25 mA
 - Programmable weak pull-ups
 - Programmable interrupt-on-change pins
- Timer0: 8-Bit Timer/Counter with 8-Bit Prescaler
- Enhanced Timer1:
 - 16-bit timer/counter with prescaler
 - External Gate Input mode
 - Dedicated, low-power 32 kHz oscillator driver
- Timer2: 8-Bit Timer/Counter with 8-Bit Period Register, Prescaler and Postscaler

PIC12LF1840T39A

- Enhanced CCP (ECCP) module:
 - Software selectable time bases
 - Auto-shutdown and auto-restart
 - PWM steering
- Master Synchronous Serial Port (MSSP) with SPI and I²C™ with:
 - 7-bit address masking
 - SMBus/PMBus™ compatibility
- Enhanced Universal Synchronous Asynchronous Receiver Transmitter (EUSART) module:
 - RS-232, RS-485 and LIN compatible
 - Auto-Baud Detect
- Capacitive Sensing (CPS) module (mTouch™):
 - 4 input channels
- Data Signal Modulator module:
 - Selectable modulator and carrier sources
- SR Latch:
 - Multiple Set/Reset input options
 - Emulates 555 Timer applications

TABLE 1: PIC12LF1840T39A FEATURE SUMMARY

Device	Program Memory Flash (words)	Data Memory EEPROM (Bytes)	Data Memory SRAM (Bytes)	I/Os ⁽¹⁾	10-bit ADC (ch)	CapSense (ch)	Comparators	Timers (8/16-bit)	EUSART	MSSP (I ² C™/SPI)	ECCP (Half-Bridge)	SR Latch	RF Transmitter	Debug ⁽²⁾
PIC12LF1840T39A	4K	256	256	6	4	4	1	2/1	1	1	1	Yes	Yes	I

Note 1: One pin is input-only.

Note 2: I – Debugging, Integrated on Chip; H – Debugging, Debug Header Available

Note: Pin details are subject to change.

FIGURE 1: 14-PIN DIAGRAM, PIC12LF1840T39A (TSSOP)

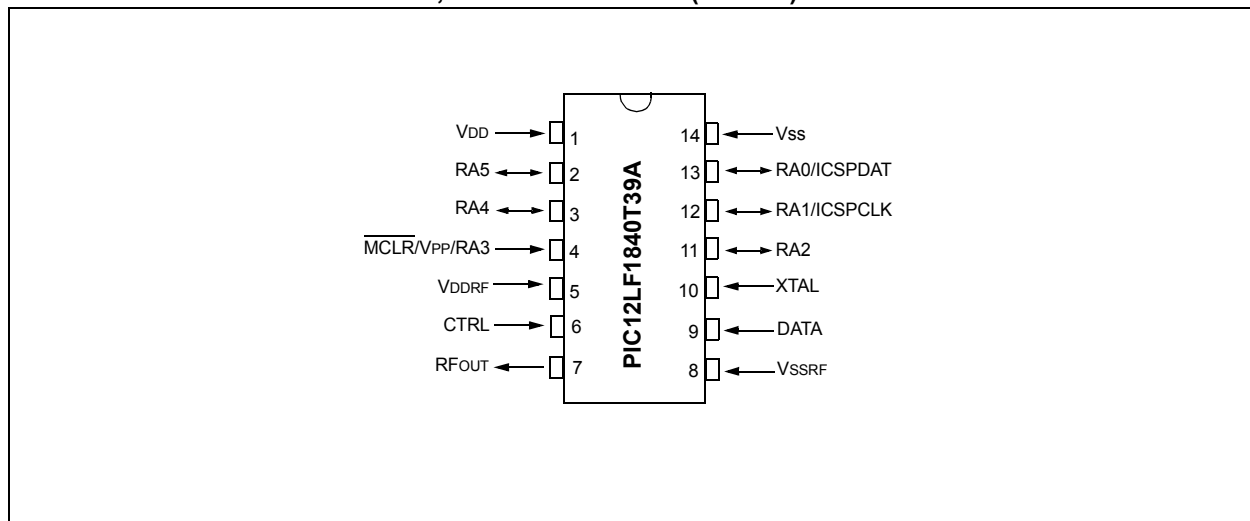

TABLE 2: 14-PIN ALLOCATION TABLE (PIC12LF1840T39A)

I/O	14-Pin TSSOP	A/D	Reference	CapSense	Comparator	SR Latch	Timers	ECCP	EUSART	MSSP	Interrupt	Modulator	Pull-up	Basic	RF Transmitter
RA0	13	AN0	DACOUT	CPS0	C1IN+	—	—	P1B ⁽¹⁾	TX ⁽¹⁾ CK ⁽¹⁾	SDO ⁽¹⁾ SS ⁽¹⁾	IOC	MDOUT	Y	ICSPDAT ICDDAT	—
RA1	12	AN1	VREF	CPS1	C1IN0-	SRI	—	—	RX ⁽¹⁾ DT ⁽¹⁾	SCL SCK	IOC	MDMIN	Y	ICSPCLK	—
RA2	11	AN2	—	CPS2	C1OUT	SRQ	T0CKI	CCP1 ⁽¹⁾ P1A ⁽¹⁾ FLT0	—	SDA SDI	INT IOC	MDCOM1	Y	—	—
RA3	4	—	—	—	—	—	T1G ⁽²⁾	—	—	SS ⁽¹⁾	IOC	—	Y	MCLR VPP	—
RA4	3	AN3	—	CPS3	C1IN1-	—	T1G ⁽¹⁾ T1OSO	P1B ⁽¹⁾	TX ⁽¹⁾ CK ⁽¹⁾	SDO ⁽¹⁾	IOC	MDCIN2	Y	OSC2 CLKOUT CLKR	—
RA5	2	—	—	—	—	SRNQ	T1CKI T1OSI	CCP1 ⁽¹⁾ P1A ⁽¹⁾	RX ⁽¹⁾ DT ⁽¹⁾	—	IOC	—	Y	OSC1 CLKIN	—
VDD	1	—	—	—	—	—	—	—	—	—	—	—	—	VDD	—
VSS	14	—	—	—	—	—	—	—	—	—	—	—	—	VSS	—
CTRL	6	—	—	—	—	—	—	—	—	—	—	—	—	—	CTRL
RFOUT	7	—	—	—	—	—	—	—	—	—	—	—	—	—	RFOUT
DATA	9	—	—	—	—	—	—	—	—	—	—	—	—	—	DATA
XTAL	10	—	—	—	—	—	—	—	—	—	—	—	—	—	XTAL
VDDRF	5	—	—	—	—	—	—	—	—	—	—	—	—	—	VDDRF
VSSRF	8	—	—	—	—	—	—	—	—	—	—	—	—	—	VSSRF

Note 1: Pin function is selectable via the APFCON register.

PIC12LF1840T39A

APPENDIX A: REVISION HISTORY

Revision A (03/2012)

Initial release of this document.

Note the following details of the code protection feature on Microchip devices:

- Microchip products meet the specification contained in their particular Microchip Data Sheet.
- Microchip believes that its family of products is one of the most secure families of its kind on the market today, when used in the intended manner and under normal conditions.
- There are dishonest and possibly illegal methods used to breach the code protection feature. All of these methods, to our knowledge, require using the Microchip products in a manner outside the operating specifications contained in Microchip's Data Sheets. Most likely, the person doing so is engaged in theft of intellectual property.
- Microchip is willing to work with the customer who is concerned about the integrity of their code.
- Neither Microchip nor any other semiconductor manufacturer can guarantee the security of their code. Code protection does not mean that we are guaranteeing the product as “unbreakable.”

Code protection is constantly evolving. We at Microchip are committed to continuously improving the code protection features of our products. Attempts to break Microchip's code protection feature may be a violation of the Digital Millennium Copyright Act. If such acts allow unauthorized access to your software or other copyrighted work, you may have a right to sue for relief under that Act.

Information contained in this publication regarding device applications and the like is provided only for your convenience and may be superseded by updates. It is your responsibility to ensure that your application meets with your specifications. MICROCHIP MAKES NO REPRESENTATIONS OR WARRANTIES OF ANY KIND WHETHER EXPRESS OR IMPLIED, WRITTEN OR ORAL, STATUTORY OR OTHERWISE, RELATED TO THE INFORMATION, INCLUDING BUT NOT LIMITED TO ITS CONDITION, QUALITY, PERFORMANCE, MERCHANTABILITY OR FITNESS FOR PURPOSE. Microchip disclaims all liability arising from this information and its use. Use of Microchip devices in life support and/or safety applications is entirely at the buyer's risk, and the buyer agrees to defend, indemnify and hold harmless Microchip from any and all damages, claims, suits, or expenses resulting from such use. No licenses are conveyed, implicitly or otherwise, under any Microchip intellectual property rights.

Trademarks

The Microchip name and logo, the Microchip logo, dsPIC, KEELOQ, KEELOQ logo, MPLAB, PIC, PICmicro, PICSTART, PIC³² logo, rPIC and UNI/O are registered trademarks of Microchip Technology Incorporated in the U.S.A. and other countries.

FilterLab, Hampshire, HI-TECH C, Linear Active Thermistor, MXDEV, MXLAB, SEEVAL and The Embedded Control Solutions Company are registered trademarks of Microchip Technology Incorporated in the U.S.A.

Analog-for-the-Digital Age, Application Maestro, chipKIT, chipKIT logo, CodeGuard, dsPICDEM, dsPICDEM.net, dsPICworks, dsSPEAK, ECAN, ECONOMONITOR, FanSense, HI-TIDE, In-Circuit Serial Programming, ICSP, Mindi, MiWi, MPASM, MPLAB Certified logo, MPLIB, MPLINK, mTouch, Omniscient Code Generation, PICC, PICC-18, PICDEM, PICDEM.net, PICKit, PICtail, REAL ICE, rLAB, Select Mode, Total Endurance, TSHARC, UniWinDriver, WiperLock and ZENA are trademarks of Microchip Technology Incorporated in the U.S.A. and other countries.

SQTP is a service mark of Microchip Technology Incorporated in the U.S.A.

All other trademarks mentioned herein are property of their respective companies.

© 2012, Microchip Technology Incorporated, Printed in the U.S.A., All Rights Reserved.

 Printed on recycled paper.

ISBN: 9781620761120

Microchip received ISO/TS-16949:2009 certification for its worldwide headquarters, design and wafer fabrication facilities in Chandler and Tempe, Arizona; Gresham, Oregon and design centers in California and India. The Company's quality system processes and procedures are for its PIC[®] MCUs and dsPIC[®] DSCs, KEELOQ[®] code hopping devices, Serial EEPROMs, microperipherals, nonvolatile memory and analog products. In addition, Microchip's quality system for the design and manufacture of development systems is ISO 9001:2000 certified.

**QUALITY MANAGEMENT SYSTEM
CERTIFIED BY DNV
= ISO/TS 16949 =**



MICROCHIP

Worldwide Sales and Service

AMERICAS

Corporate Office
2355 West Chandler Blvd.
Chandler, AZ 85224-6199
Tel: 480-792-7200
Fax: 480-792-7277
Technical Support:
<http://www.microchip.com/support>
Web Address:
www.microchip.com

Atlanta
Duluth, GA
Tel: 678-957-9614
Fax: 678-957-1455

Boston
Westborough, MA
Tel: 774-760-0087
Fax: 774-760-0088

Chicago
Itasca, IL
Tel: 630-285-0071
Fax: 630-285-0075

Cleveland
Independence, OH
Tel: 216-447-0464
Fax: 216-447-0643

Dallas
Addison, TX
Tel: 972-818-7423
Fax: 972-818-2924

Detroit
Farmington Hills, MI
Tel: 248-538-2250
Fax: 248-538-2260

Indianapolis
Noblesville, IN
Tel: 317-773-8323
Fax: 317-773-5453

Los Angeles
Mission Viejo, CA
Tel: 949-462-9523
Fax: 949-462-9608

Santa Clara
Santa Clara, CA
Tel: 408-961-6444
Fax: 408-961-6445

Toronto
Mississauga, Ontario,
Canada
Tel: 905-673-0699
Fax: 905-673-6509

ASIA/PACIFIC

Asia Pacific Office
Suites 3707-14, 37th Floor
Tower 6, The Gateway
Harbour City, Kowloon
Hong Kong
Tel: 852-2401-1200
Fax: 852-2401-3431

Australia - Sydney
Tel: 61-2-9868-6733
Fax: 61-2-9868-6755

China - Beijing
Tel: 86-10-8569-7000
Fax: 86-10-8528-2104

China - Chengdu
Tel: 86-28-8665-5511
Fax: 86-28-8665-7889

China - Chongqing
Tel: 86-23-8980-9588
Fax: 86-23-8980-9500

China - Hangzhou
Tel: 86-571-2819-3187
Fax: 86-571-2819-3189

China - Hong Kong SAR
Tel: 852-2401-1200
Fax: 852-2401-3431

China - Nanjing
Tel: 86-25-8473-2460
Fax: 86-25-8473-2470

China - Qingdao
Tel: 86-532-8502-7355
Fax: 86-532-8502-7205

China - Shanghai
Tel: 86-21-5407-5533
Fax: 86-21-5407-5066

China - Shenyang
Tel: 86-24-2334-2829
Fax: 86-24-2334-2393

China - Shenzhen
Tel: 86-755-8203-2660
Fax: 86-755-8203-1760

China - Wuhan
Tel: 86-27-5980-5300
Fax: 86-27-5980-5118

China - Xian
Tel: 86-29-8833-7252
Fax: 86-29-8833-7256

China - Xiamen
Tel: 86-592-2388138
Fax: 86-592-2388130

China - Zhuhai
Tel: 86-756-3210040
Fax: 86-756-3210049

ASIA/PACIFIC

India - Bangalore
Tel: 91-80-3090-4444
Fax: 91-80-3090-4123

India - New Delhi
Tel: 91-11-4160-8631
Fax: 91-11-4160-8632

India - Pune
Tel: 91-20-2566-1512
Fax: 91-20-2566-1513

Japan - Osaka
Tel: 81-66-152-7160
Fax: 81-66-152-9310

Japan - Yokohama
Tel: 81-45-471-6166
Fax: 81-45-471-6122

Korea - Daegu
Tel: 82-53-744-4301
Fax: 82-53-744-4302

Korea - Seoul
Tel: 82-2-554-7200
Fax: 82-2-558-5932 or
82-2-558-5934

Malaysia - Kuala Lumpur
Tel: 60-3-6201-9857
Fax: 60-3-6201-9859

Malaysia - Penang
Tel: 60-4-227-8870
Fax: 60-4-227-4068

Philippines - Manila
Tel: 63-2-634-9065
Fax: 63-2-634-9069

Singapore
Tel: 65-6334-8870
Fax: 65-6334-8850

Taiwan - Hsin Chu
Tel: 886-3-5778-366
Fax: 886-3-5770-955

Taiwan - Kaohsiung
Tel: 886-7-536-4818
Fax: 886-7-330-9305

Taiwan - Taipei
Tel: 886-2-2500-6610
Fax: 886-2-2508-0102

Thailand - Bangkok
Tel: 66-2-694-1351
Fax: 66-2-694-1350

EUROPE

Austria - Wels
Tel: 43-7242-2244-39
Fax: 43-7242-2244-393

Denmark - Copenhagen
Tel: 45-4450-2828
Fax: 45-4485-2829

France - Paris
Tel: 33-1-69-53-63-20
Fax: 33-1-69-30-90-79

Germany - Munich
Tel: 49-89-627-144-0
Fax: 49-89-627-144-44

Italy - Milan
Tel: 39-0331-742611
Fax: 39-0331-466781

Netherlands - Drunen
Tel: 31-416-690399
Fax: 31-416-690340

Spain - Madrid
Tel: 34-91-708-08-90
Fax: 34-91-708-08-91

UK - Wokingham
Tel: 44-118-921-5869
Fax: 44-118-921-5820

11/29/11