



Chipsmall Limited consists of a professional team with an average of over 10 year of expertise in the distribution of electronic components. Based in Hongkong, we have already established firm and mutual-benefit business relationships with customers from,Europe,America and south Asia,supplying obsolete and hard-to-find components to meet their specific needs.

With the principle of “Quality Parts,Customers Priority,Honest Operation,and Considerate Service”,our business mainly focus on the distribution of electronic components. Line cards we deal with include Microchip,ALPS,ROHM,Xilinx,Pulse,ON,Everlight and Freescale. Main products comprise IC,Modules,Potentiometer,IC Socket,Relay,Connector.Our parts cover such applications as commercial,industrial, and automotives areas.

We are looking forward to setting up business relationship with you and hope to provide you with the best service and solution. Let us make a better world for our industry!



Contact us

Tel: +86-755-8981 8866 Fax: +86-755-8427 6832

Email & Skype: info@chipsmall.com Web: www.chipsmall.com

Address: A1208, Overseas Decoration Building, #122 Zhenhua RD., Futian, Shenzhen, China



Full-Featured 28/40-Pin Microcontroller Product Brief

Description

PIC16(L)F1885X/7X microcontrollers feature Analog, Core Independent Peripherals and communication peripherals, combined with eXtreme Low Power (XLP) for a wide range of general purpose and low-power applications. The family will feature the CRC/SCAN, HLT and Windowed WDT to support customers looking to add safety to their application. Additionally, this family includes up to 56 KB of Flash memory, along with a 10-bit ADC with MATHPAK extensions for automated signal analysis to reduce the complexity of the application.

Core Features

- C Compiler Optimized RISC Architecture
- Only 49 Instructions
- Operating Speed:
 - DC – 32 MHz clock input
 - 125 ns minimum instruction cycle
- Interrupt Capability
- 16-Level Deep Hardware Stack
- Three 8-Bit Timers (TMR2/4/6) with Hardware Limit Timer (HLT) Extensions
- Four 16-Bit Timers (TMR0/1/3/5)
- Low Current Power-on Reset (POR)
- Configurable Power-up Timer (PWRTE)
- Brown-out Reset (BOR) with Fast Recovery
- Low-Power BOR (LPBOR) Option
- Windowed Watchdog Timer (WWDT):
 - Variable prescaler selection
 - Variable window size selection
 - All sources configurable in hardware or software
- Programmable Code Protection

Memory

- Up to 56 KB Flash Program Memory
- Up to 4 KB Data SRAM Memory
- 256B of EEPROM
- Direct, Indirect and Relative Addressing modes

Operating Characteristics

- Operating Voltage Range:
 - 1.8V to 3.6V (PIC16LF188XX)
 - 2.3V to 5.5V (PIC16F188XX)
- Temperature Range:
 - Industrial: -40°C to 85°C
 - Extended: -40°C to 125°C

Power-Saving Functionality

- Doze mode: Ability to run the CPU core slower than the system clock
- Idle mode: Ability to halt CPU core while internal peripherals continue operating
- Sleep mode: Lowest Power Consumption
- Peripheral Module Disable (PMD):
 - Ability to disable hardware module to minimize power consumption of unused peripherals

eXtreme Low-Power (XLP) Features

- Sleep mode: 50 nA @ 1.8V, typical
- Watchdog Timer: 500 nA @ 1.8V, typical
- Secondary Oscillator: 500 nA @ 32 kHz
- Operating Current:
 - 8 uA @ 32 kHz, 1.8V, typical
 - 32 uA/MHz @ 1.8V, typical

Digital Peripherals

- Four Configurable Logic Cells (CLC):
 - Integrated combinational and sequential logic
- Complementary Waveform Generator (CWG):
 - Rising and falling edge dead-band control
 - Full-bridge, half-bridge, 1-channel drive
 - Multiple signal sources
- Five Capture/Compare/PWM (CCP) modules
- PWM: Two 10-bit Pulse-Width Modulators
- Numerically Controlled Oscillator (NCO):
 - Generates true linear frequency control and increased frequency resolution
 - Input Clock: $0 \text{ Hz} < f_{\text{NCO}} < 32 \text{ MHz}$
 - Resolution: $f_{\text{NCO}}/220$
- Two Signal Measurement Timers (SMT):
 - 24-bit Signal Measurement Timer
 - Up to 12 different Acquisition modes
- Cyclical Redundancy Check (CRC/SCAN):
 - 16-bit CRC
 - Scans memory for NVM integrity

PIC16(L)F1885X/7X

- Serial Communications:
 - SPI, I²C™, EUSART
 - RS-232, RS-485, LIN compatible
 - Auto-Baud Detect, Auto-Wake-up on start
- Up to 36 I/O Pins:
 - Individually programmable pull-ups, slew rate control interrupt-on-change with edge-select
- Peripheral Pin Select (PPS):
 - Enables pin mapping of digital I/O
- Data Signal Modulator (DSM)
- 5-Bit Digital-to-Analog Converter (DAC):
 - 5-bit resolution, rail-to-rail
 - Positive Reference Selection
 - Unbuffered I/O pin output
 - Internal connections to ADCs and comparators
- Voltage Reference:
 - Fixed Voltage Reference with 1.024V, 2.048V and 4.096V output levels

Analog Peripherals

- Analog-to-Digital Converter (ADC) with MATHPAK Extensions:
 - 10-bit with up to 35 external channels
 - Automated post-processing
 - Automates math functions on input signals: averaging, filter calculations, oversampling and threshold comparison
 - Operates in Sleep
- Two Comparators:
 - Fixed Voltage Reference at (non) inverting input(s)
 - Comparator outputs externally accessible

Clocking Structure

- High-Precision Internal Oscillator:
 - Selectable frequency range up to 32 MHz
 - x2/x4 PLL with Internal and External Sources
- Low-Power Internal 31 kHz Oscillator (LFINTOSC)
- External 32 kHz Crystal Oscillator (SOSC)

TABLE 1: PIC16(L)F188XX FAMILY TYPES

Device	Data Sheet Index	Program Flash Memory (words)	Program Flash Memory (KB)	EEPROM (bytes)	Data SRAM (bytes)	I/O Pins ⁽²⁾	10-bit ADC MATHPAK (ch)	5-bit DAC	Comparator	8-bit (w/HLT)/16-bit Timers	SMT	Windowed Watchdog Timer	CRC + Memory Scan	CCP/10-bit PWM	Zero-Cross Detect	CWG	NCO	CLC	DSM	EUSART/I ² C™/SPI	Peripheral Pin Select
PIC16(L)F18854	(A)	4096	7	256	512	25	24	1	2	3/4	2	Y	Y	5/2	Y	3	1	4	1	1/2	Y
PIC16(L)F18855	(B)	8192	14	256	1024	25	24	1	2	3/4	2	Y	Y	5/2	Y	3	1	4	1	1/2	Y
PIC16(L)F18875	(B)	8192	14	256	1024	36	35	1	2	3/4	2	Y	Y	5/2	Y	3	1	4	1	1/2	Y
PIC16(L)F18856	(C)	16384	28	256	2048	25	24	1	2	3/4	2	Y	Y	5/2	Y	3	1	4	1	1/2	Y
PIC16(L)F18876	(C)	16384	28	256	2048	36	35	1	2	3/4	2	Y	Y	5/2	Y	3	1	4	1	1/2	Y
PIC16(L)F18857	(D)	32768	56	256	4096	25	24	1	2	3/4	2	Y	Y	5/2	Y	3	1	4	1	1/2	Y
PIC16(L)F18877	(D)	32768	56	256	4096	36	35	1	2	3/4	2	Y	Y	5/2	Y	3	1	4	1	1/2	Y

Note 1: One pin is input-only.

Data Sheet Index:

- A** Future Release [PIC16\(L\)F18854 Data Sheet, 28-Pin, Full-Featured 8-bit Microcontrollers](#)
- B** Future Release [PIC16\(L\)F18855/75 Data Sheet, 28/40-Pin, Full-Featured 8-bit Microcontrollers](#)
- C** Future Release [PIC16\(L\)F18856/76 Data Sheet, 28/40-Pin, Full-Featured 8-bit Microcontrollers](#)
- D** Future Release [PIC16\(L\)F18857/77 Data Sheet, 28/40-Pin, Full-Featured 8-bit Microcontrollers](#)

Note: For other small form-factor package availability and marking information, please visit <http://www.microchip.com/packaging> or contact your local sales office.

PIC16(L)F1885X/7X

TABLE 2: PACKAGES

Packages	(S)PDIP	SOIC	SSOP	QFN (6x6)	UQFN (4x4)	TQFP	QFN (8x8)	UQFN (5x5)
PIC16(L)F18854	X	X	X	X	X			
PIC16(L)F18855	X	X	X	X	X			
PIC16(L)F18875	X					X	X	X
PIC16(L)F18856	X	X	X	X	X			
PIC16(L)F18876	X					X	X	X
PIC16(L)F18857	X	X	X	X				
PIC16(L)F18877	X					X	X	X

Note: Pin details are subject to change.

PIC16(L)F1885X/7X

PIN DIAGRAMS

Pin Diagram – 28-Pin (S)PDIP, SOIC, SSOP

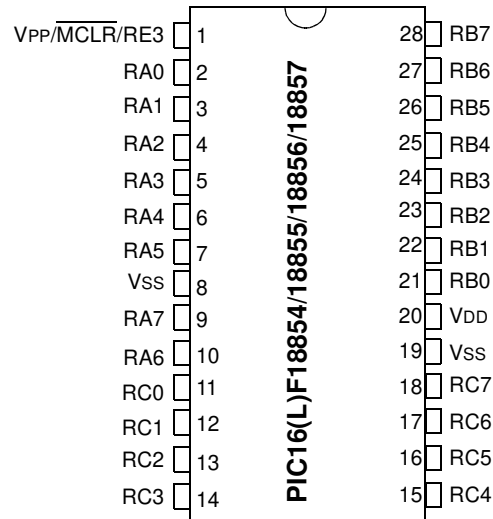

Note 1: See [Table 3](#) for location of all peripheral functions.

2: All V_{DD} and all V_{SS} pins must be connected at the circuit board level. Allowing one or more V_{SS} or V_{DD} pins to float may result in degraded electrical performance or non-functionality.

Pin Diagram – 28-Pin UQFN (4x4) (except for PIC16F18857) and QFN (6x6)

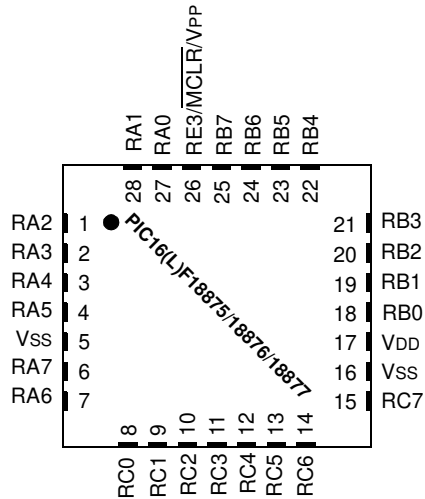

Note 1: See [Table 3](#) for location of all peripheral functions.

2: All V_{DD} and all V_{SS} pins must be connected at the circuit board level. Allowing one or more V_{SS} or V_{DD} pins to float may result in degraded electrical performance or non-functionality.

3: The bottom pad of the QFN/UQFN package should be connected to V_{SS} at the circuit board level.

PIC16(L)F1885X/7X

Pin Diagram – 40-Pin PDIP

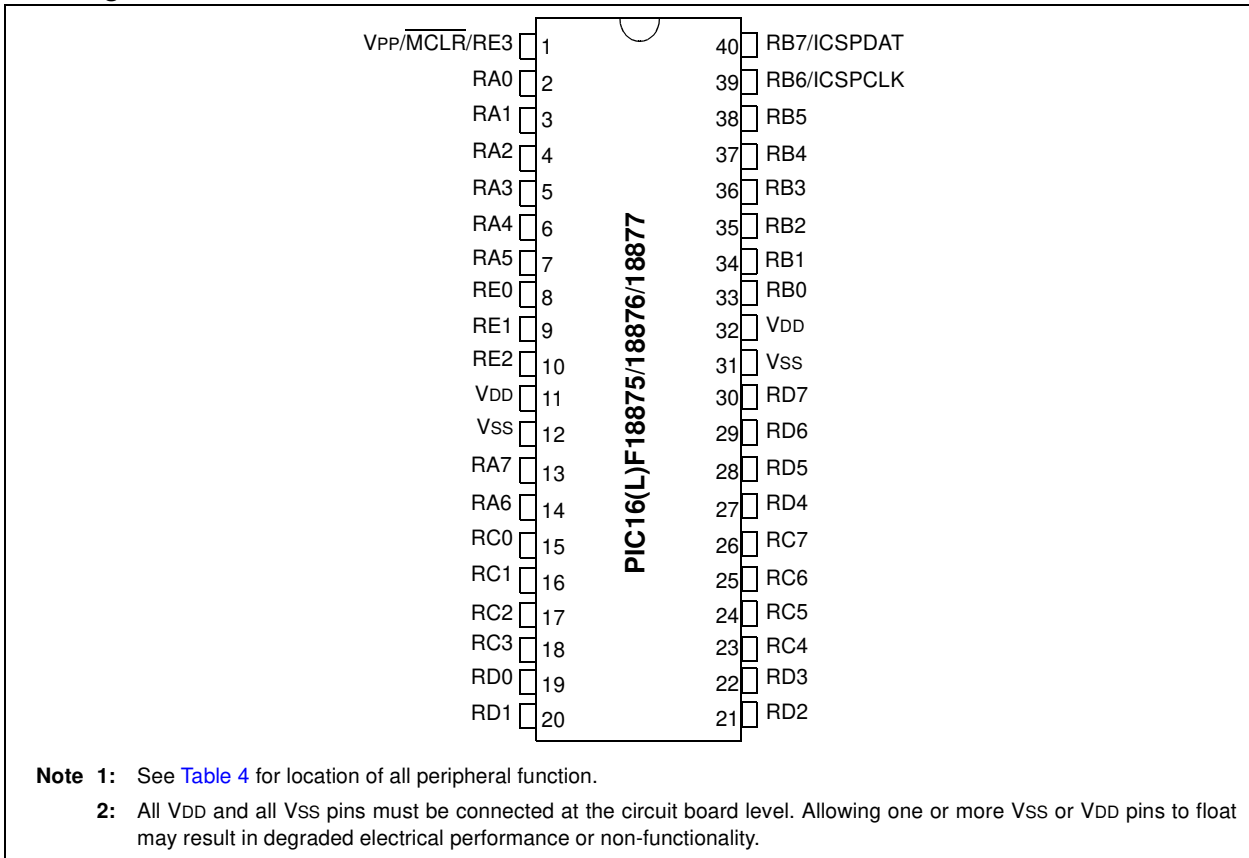

Pin Diagram – 44-Pin TQFP

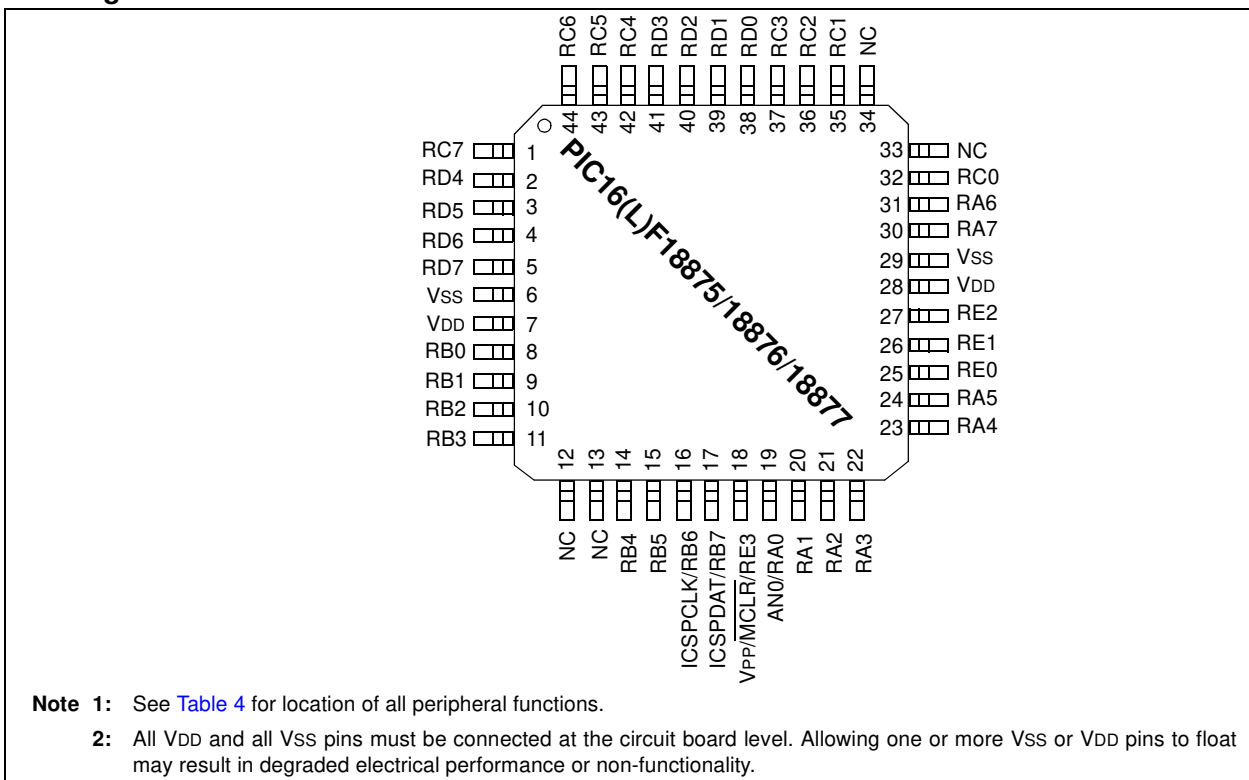

PIC16(L)F1885X/7X

Pin Diagram – 40-Pin UQFN (5x5)

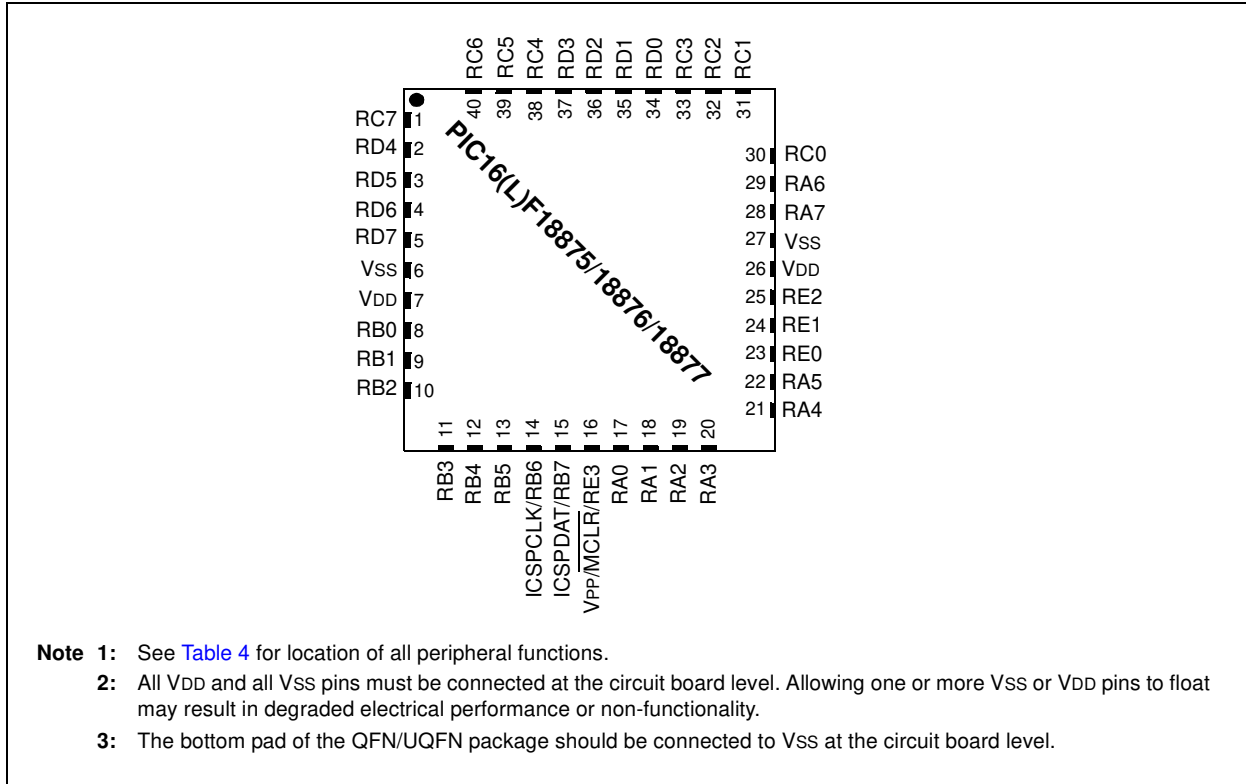

Pin Diagram – 44-Pin QFN (8x8)

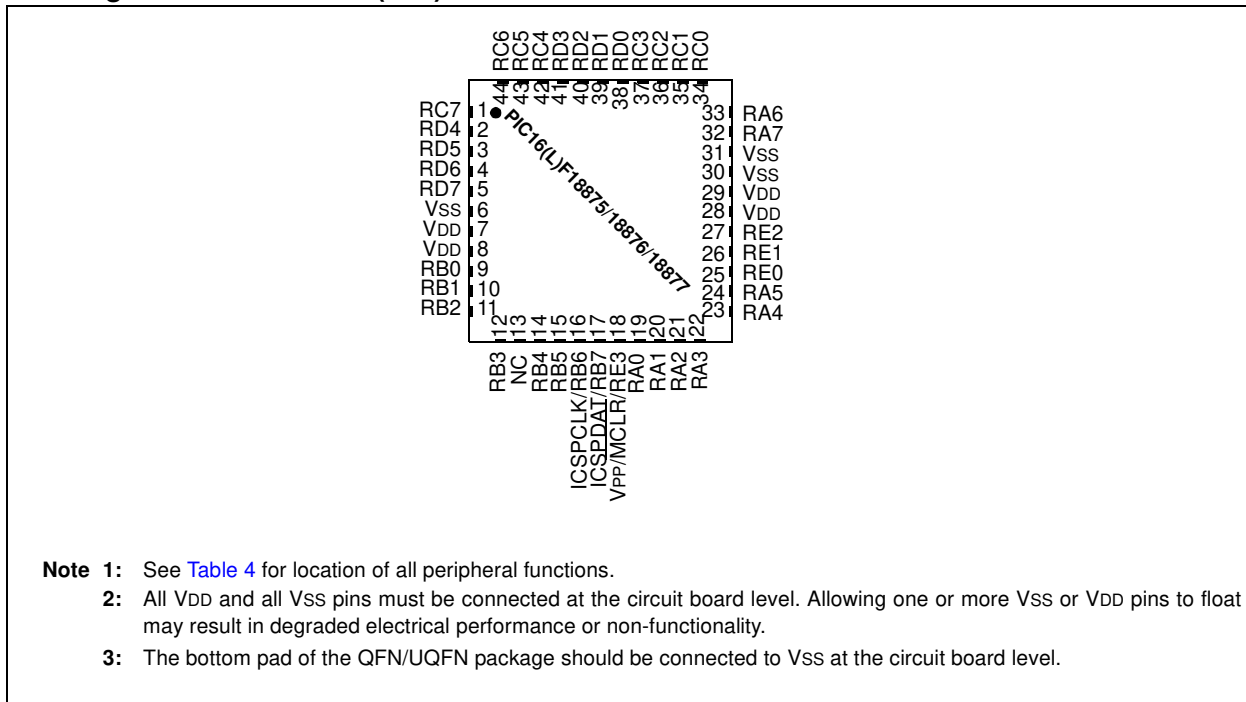

PIN ALLOCATION TABLES

TABLE 3: 28-PIN ALLOCATION TABLE (PIC16(L)F1885X)

I/O	28-Pin SPDIP/SOIC/SSOP	28-Pin (U)QFN	ADC	Voltage Reference	DAC	Comparators	Zero-Cross Detect	MSSP (SPI/I ² C™)	EUSART	DSM	Timers/SMT	CCP and PWM	CWG	CLC	NCO	Clock Reference (CLKR)	Interrupt-on-Change	Basic
RA0	2	27	ANA0	—	—	C1IN0- C2IN0-	—	—	—	—	—	—	—	CLCIN0 ⁽¹⁾	—	—	IOCA0	—
RA1	3	28	ANA1	—	—	C1IN1- C2IN1-	—	—	—	—	—	—	—	CLCIN1 ⁽¹⁾	—	—	IOCA1	—
RA2	4	1	ANA2	VREF-	DAC1OUT1	C1IN0+ C2IN0+	—	—	—	—	—	—	—	—	—	—	IOCA2	—
RA3	5	2	ANA3	VREF+	—	C1IN1+	—	—	—	MDCIN1 ⁽¹⁾	—	—	—	—	—	—	IOCA3	—
RA4	6	3	ANA4	—	—	—	—	—	—	MDCIN2 ⁽¹⁾	T0CKI ⁽¹⁾	CCP5 ⁽¹⁾	—	—	—	—	IOCA4	—
RA5	7	4	ANA5	—	—	—	—	SS1 ⁽¹⁾	—	MDMIN ⁽¹⁾	—	—	—	—	—	—	IOCA5	—
RA6	10	7	ANA6	—	—	—	—	—	—	—	—	—	—	—	—	—	IOCA6	OSC2 CLKOUT
RA7	9	6	ANA7	—	—	—	—	—	—	—	—	—	—	—	—	—	IOCA7	OSC1 CLKIN
RB0	21	18	ANB0	—	—	C2IN1+	ZCD	SS2 ⁽¹⁾	—	—	—	CCP4 ⁽¹⁾	CWG1IN ⁽¹⁾	—	—	—	INT ⁽¹⁾ IOCB0	—
RB1	22	19	ANB1	—	—	C1IN3- C2IN3-	—	SCL2 ^(3,4) SCK2 ⁽¹⁾	—	—	—	—	CWG2IN ⁽¹⁾	—	—	—	IOCB1	—
RB2	23	20	ANB2	—	—	—	—	SDA2 ^(3,4) SDI2 ⁽¹⁾	—	—	—	—	CWG3IN ⁽¹⁾	—	—	—	IOCB2	—
RB3	24	21	ANB3	—	—	C1IN2- C2IN2-	—	—	—	—	—	—	—	—	—	—	IOCB3	—
RB4	25	22	ANB4 ADCACT ⁽¹⁾	—	—	—	—	—	—	—	T5G ⁽¹⁾ SMTWIN2 ⁽¹⁾	—	—	—	—	—	IOCB4	—

- Note**
- 1: This is a PPS re-mappable input signal. The input function may be moved from the default location shown to one of several other PORTx pins. Refer to Table 5 for details on which PORT pins may be used for this signal.
 - 2: All output signals shown in this row are PPS re-mappable. These signals may be mapped to output onto one of several PORTx pin options as described in Table 6.
 - 3: This is a bidirectional signal. For normal module operation, the firmware should map this signal to the same pin in both the PPS input and PPS output registers.
 - 4: These pins are configured for I²C™ logic levels.; The SCLx/SDAx signals may be assigned to any of the RB1/RB2/RC3/RC4 pins. PPS assignments to the other pins (e.g., RA5) will operate, but input logic levels will be standard TTL/ST, as selected by the INLVL register, instead of the I²C specific or SMBUS input buffer thresholds.

TABLE 3: 28-PIN ALLOCATION TABLE (PIC16(L)F1885X)

I/O	28-Pin SPDIP/SOIC/SSOP		ADC	Voltage Reference	DAC	Comparators	Zero-Cross Detect	MSSP (SPI/I ² C™)	EUSART	DSM	Timers/SMT	CCP and PWM	CWG	CLC	NCO	Clock Reference (CLKR)	Interrupt-on-Change	Basic
	28-Pin	(U)QFN																
RB5	26	23	ANB5	—	—	—	—	—	—	—	T1G ⁽¹⁾ SMTSIG2 ⁽¹⁾	CCP3 ⁽¹⁾	—	—	—	—	IOCB5	—
RB6	27	24	ANB6	—	—	—	—	—	—	—	—	—	—	CLCIN2 ⁽¹⁾	—	—	IOCB6	ICSPCLK
RB7	28	25	ANB7	—	DAC1OUT2	—	—	—	—	—	T6IN ⁽¹⁾	—	—	CLCIN3 ⁽¹⁾	—	—	IOCB7	ICSPDAT
RC0	11	6	ANC0	—	—	—	—	—	—	—	T1CKI ⁽¹⁾ T3CKI ⁽¹⁾ T3G ⁽¹⁾ SMTWIN1 ⁽¹⁾	—	—	—	—	—	IOCC0	SOSCO
RC1	12	9	ANC1	—	—	—	—	—	—	—	SMTSIG1 ⁽¹⁾	CCP2 ⁽¹⁾	—	—	—	—	IOCC1	SOSCI
RC2	13	10	ANC2	—	—	—	—	—	—	—	T5CKI ⁽¹⁾	CCP1 ⁽¹⁾	—	—	—	—	IOCC2	—
RC3	14	11	ANC3	—	—	—	—	SCL1 ^(3,4) SCK1 ⁽¹⁾	—	—	T2IN ⁽¹⁾	—	—	—	—	—	IOCC3	—
RC4	15	12	ANC4	—	—	—	—	SDA1 ^(3,4) SDI1 ⁽¹⁾	—	—	—	—	—	—	—	—	IOCC4	—
RC5	16	13	ANC5	—	—	—	—	—	—	—	T4IN ⁽¹⁾	—	—	—	—	—	IOCC5	—
RC6	17	14	ANC6	—	—	—	—	—	CK(3)	—	—	—	—	—	—	—	IOCC6	—
RC7	18	15	ANC7	—	—	—	—	—	RX ⁽¹⁾ DT ⁽³⁾	—	—	—	—	—	—	—	IOCC7	—
RE3	1	26	—	—	—	—	—	—	—	—	—	—	—	—	—	—	IOCE3	$\overline{\text{MCLR}}$ V _{PP}
V _{DD}	20	17	—	—	—	—	—	—	—	—	—	—	—	—	—	—	—	—
V _{SS}	8, 19	5, 16	—	—	—	—	—	—	—	—	—	—	—	—	—	—	—	—

- Note**
- 1: This is a PPS re-mappable input signal. The input function may be moved from the default location shown to one of several other PORTx pins. Refer to [Table 5](#) for details on which PORT pins may be used for this signal.
 - 2: All output signals shown in this row are PPS re-mappable. These signals may be mapped to output onto one of several PORTx pin options as described in [Table 6](#).
 - 3: This is a bidirectional signal. For normal module operation, the firmware should map this signal to the same pin in both the PPS input and PPS output registers.
 - 4: These pins are configured for I²C™ logic levels.; The SCLx/SDAx signals may be assigned to any of the RB1/RB2/RC3/RC4 pins. PPS assignments to the other pins (e.g., RA5) will operate, but input logic levels will be standard TTL/ST, as selected by the INLVL register, instead of the I²C specific or SMBUS input buffer thresholds.

TABLE 3: 28-PIN ALLOCATION TABLE (PIC16(L)F1885X)

I/O	28-Pin SPDIP/SOIC/SSOP	28-Pin (U)QFN	ADC	Voltage Reference	DAC	Comparators	Zero-Cross Detect	MSSP (SPI/I ² C™)	EUSART	DSM	Timers/SMT	CCP and PWM	CWG	CLC	NCO	Clock Reference (CLKR)	Interrupt-on-Change	Basic
OUT ⁽²⁾	—	—	ADGRDA ADGRDB	—	—	C1OUT C2OUT	—	SDO1 SCK1 SDO2 SCK2	TX/ CK ⁽³⁾ DT ⁽³⁾	DSM	TMR0	CCP1 CCP2 CCP3 CCP4 CCP5 PWM6OUT PWM7OUT	CWG1A CWG1B CWG1C CWG1D CWG2A CWG2B CWG2C CWG2D CWG3A CWG3B CWG3C CWG3D	CLC1OUT CLC2OUT CLC3OUT CLC4OUT	NCO	CLKR	—	—

- Note**
- 1: This is a PPS re-mappable input signal. The input function may be moved from the default location shown to one of several other PORTx pins. Refer to [Table 5](#) for details on which PORT pins may be used for this signal.
 - 2: All output signals shown in this row are PPS re-mappable. These signals may be mapped to output onto one of several PORTx pin options as described in [Table 6](#).
 - 3: This is a bidirectional signal. For normal module operation, the firmware should map this signal to the same pin in both the PPS input and PPS output registers.
 - 4: These pins are configured for I²C™ logic levels.; The SCLx/SDAx signals may be assigned to any of the RB1/RB2/RC3/RC4 pins. PPS assignments to the other pins (e.g., RA5) will operate, but input logic levels will be standard TTL/ST, as selected by the INLVL register, instead of the I²C specific or SMBUS input buffer thresholds.

TABLE 4: 40/44-PIN ALLOCATION TABLE (PIC16(L)F1887X)

I/O	40-Pin PDIP	44-Pin TQFP	40-Pin UQFN	44-Pin QFN	ADC	Voltage Reference	DAC	Comparators	Zero-Cross Detect	MSSP (SPI/I ² C™)	EUSART	DSM	Timers/SMT	CCP and PWM	CWG	CLC	NCO	Clock Reference (CLKR)	Interrupt-on-Change	Basic
RA0	2	19	17	19	ANA0	—	—	C1IN0- C2IN0-	—	—	—	—	—	—	—	CLCIN0 ⁽¹⁾	—	—	IOCA0	—
RA1	3	20	18	20	ANA1	—	—	C1IN1- C2IN1-	—	—	—	—	—	—	—	CLCIN1 ⁽¹⁾	—	—	IOCA1	—
RA2	4	21	19	21	ANA2	VREF-	DAC1OUT1	C1IN0+ C2IN0+	—	—	—	—	—	—	—	—	—	—	IOCA2	—
RA3	5	22	20	22	ANA3	VREF+	—	C1IN1+	—	—	—	MDCIN1 ⁽¹⁾	—	—	—	—	—	—	IOCA3	—
RA4	6	23	21	23	ANA4	—	—	—	—	—	—	MDCIN2 ⁽¹⁾	T0CKI ⁽¹⁾	CCP5 ⁽¹⁾	—	—	—	—	IOCA4	—
RA5	7	24	22	24	ANA5	—	—	—	—	SS1 ⁽¹⁾	—	MDMIN ⁽¹⁾	—	—	—	—	—	—	IOCA5	—
RA6	14	31	29	33	ANA6	—	—	—	—	—	—	—	—	—	—	—	—	—	IOCA6	OSC2 CLKOUT
RA7	13	30	28	32	ANA7	—	—	—	—	—	—	—	—	—	—	—	—	—	IOCA7	OSC1 CLKIN
RB0	33	8	8	9	ANB0	—	—	C2IN1+	ZCD	SS2 ⁽¹⁾	—	—	—	CCP4 ⁽¹⁾	CWG1IN ⁽¹⁾	—	—	—	INT ⁽¹⁾ IOCB0	—
RB1	34	9	9	10	ANB1	—	—	C1IN3- C2IN3-	—	SCL2 ^(3,4) SCK2 ⁽¹⁾	—	—	—	—	CWG2IN ⁽¹⁾	—	—	—	IOCB1	—
RB2	35	10	10	11	ANB2	—	—	—	—	SDA2 ^(3,4) SDI2 ⁽¹⁾	—	—	—	—	CWG3IN ⁽¹⁾	—	—	—	IOCB2	—
RB3	36	11	11	12	ANB3	—	—	C1IN2- C2IN2-	—	—	—	—	—	—	—	—	—	—	IOCB3	—
RB4	37	14	12	14	ANB4 ADCACT ⁽¹⁾	—	—	—	—	—	—	—	T5G ⁽¹⁾ SMTWIN2 ⁽¹⁾	—	—	—	—	—	IOCB4	—
RB5	38	15	13	15	ANB5	—	—	—	—	—	—	—	T1G ⁽¹⁾ SMTSIG2 ⁽¹⁾	CCP3(1)	—	—	—	—	IOCB5	—
RB6	39	16	14	16	ANB6	—	—	—	—	—	—	—	—	—	—	CLCIN2 ⁽¹⁾	—	—	IOCB6	ICSPCLK
RB7	40	17	15	17	ANB7	—	DAC1OUT2	—	—	—	—	—	T6IN ⁽¹⁾	—	—	CLCIN3 ⁽¹⁾	—	—	IOCB7	ICSPDAT

- Note** 1: This is a PPS re-mappable input signal. The input function may be moved from the default location shown to one of several other PORTx pins. Refer to [Table 5](#) for details on which PORT pins may be used for this signal.
- 2: All output signals shown in this row are PPS re-mappable. These signals may be mapped to output onto one of several PORTx pin options as described in [Table 6](#).
- 3: This is a bidirectional signal. For normal module operation, the firmware should map this signal to the same pin in both the PPS input and PPS output registers.
- 4: These pins are configured for I²C™ logic levels.; The SCLx/SDAx signals may be assigned to any of the RB1/RB2/RC3/RC4 pins. PPS assignments to the other pins (e.g., RA5) will operate, but input logic levels will be standard TTL/ST, as selected by the INLVL register, instead of the I²C specific or SMBUS input buffer thresholds.

TABLE 4: 40/44-PIN ALLOCATION TABLE (PIC16(L)F1887X)

I/O	40-Pin PDIP	44-Pin TQFP	40-Pin UQFN	44-Pin QFN	ADC	Voltage Reference	DAC	Comparators	Zero-Cross Detect	MSSP (SPI/I ² C™)	EUSART	DSM	Timers/SMT	CCP and PWM	CWG	CLC	NCO	Clock Reference (CLKR)	Interrupt-on-Change	Basic
RC0	15	32	30	34	ANC0	—	—	—	—	—	—	—	T1CK1 ⁽¹⁾ T3CK1 ⁽¹⁾ T3G ⁽¹⁾ SMTWIN1 ⁽¹⁾	—	—	—	—	—	IOCC0	SOSCO
RC1	16	35	31	35	ANC1	—	—	—	—	—	—	—	SMTSIG1 ⁽¹⁾	CCP2 ⁽¹⁾	—	—	—	—	IOCC1	SOSCI
RC2	17	36	32	36	ANC2	—	—	—	—	—	—	—	T5CK1 ⁽¹⁾	CCP1 ⁽¹⁾	—	—	—	—	IOCC2	—
RC3	18	37	33	37	ANC3	—	—	—	—	SCL1 ^(3,4) SCK1 ⁽¹⁾	—	—	T2IN ⁽¹⁾	—	—	—	—	—	IOCC3	—
RC4	23	42	38	42	ANC4	—	—	—	—	SDA1 ^(3,4) SDI1 ⁽¹⁾	—	—	—	—	—	—	—	—	IOCC4	—
RC5	24	43	39	43	ANC5	—	—	—	—	—	—	—	T4IN ⁽¹⁾	—	—	—	—	—	IOCC5	—
RC6	25	44	40	44	ANC6	—	—	—	—	—	CK ⁽³⁾	—	—	—	—	—	—	—	IOCC6	—
RC7	26	1	1	1	ANC7	—	—	—	—	—	RX ⁽¹⁾ DT ⁽³⁾	—	—	—	—	—	—	—	IOCC7	—
RD0	19	38	34	38	AND0	—	—	—	—	—	—	—	—	—	—	—	—	—	—	—
RD1	20	39	35	39	AND1	—	—	—	—	—	—	—	—	—	—	—	—	—	—	—
RD2	21	40	36	40	AND2	—	—	—	—	—	—	—	—	—	—	—	—	—	—	—
RD3	22	41	37	41	AND3	—	—	—	—	—	—	—	—	—	—	—	—	—	—	—
RD4	27	2	2	2	AND4	—	—	—	—	—	—	—	—	—	—	—	—	—	—	—
RD5	28	3	3	3	AND5	—	—	—	—	—	—	—	—	—	—	—	—	—	—	—
RD6	29	4	4	4	AND6	—	—	—	—	—	—	—	—	—	—	—	—	—	—	—
RD7	30	5	5	5	AND7	—	—	—	—	—	—	—	—	—	—	—	—	—	—	—
RE0	8	25	23	25	ANE0	—	—	—	—	—	—	—	—	—	—	—	—	—	—	—
RE1	9	26	24	26	ANE1	—	—	—	—	—	—	—	—	—	—	—	—	—	—	—
RE2	10	27	25	27	ANE2	—	—	—	—	—	—	—	—	—	—	—	—	—	—	—

- Note**
- 1: This is a PPS re-mappable input signal. The input function may be moved from the default location shown to one of several other PORTx pins. Refer to [Table 5](#) for details on which PORT pins may be used for this signal.
 - 2: All output signals shown in this row are PPS re-mappable. These signals may be mapped to output onto one of several PORTx pin options as described in [Table 6](#).
 - 3: This is a bidirectional signal. For normal module operation, the firmware should map this signal to the same pin in both the PPS input and PPS output registers.
 - 4: These pins are configured for I²C™ logic levels.; The SCLx/SDAx signals may be assigned to any of the RB1/RB2/RC3/RC4 pins. PPS assignments to the other pins (e.g., RA5) will operate, but input logic levels will be standard TTL/ST, as selected by the INLVL register, instead of the I²C specific or SMBUS input buffer thresholds.

TABLE 4: 40/44-PIN ALLOCATION TABLE (PIC16(L)F1887X)

I/O	40-Pin PDIP	44-Pin TQFP	40-Pin UQFN	44-Pin QFN	ADC	Voltage Reference	DAC	Comparators	Zero-Cross Detect	MSSP (SPI/I ² C™)	EUSART	DSM	Timers/SMT	CCP and PWM	CWG	CLC	NCO	Clock Reference (CLKR)	Interrupt-on-Change	Basic
RE3	1	18	16	18	—	—	—	—	—	—	—	—	—	—	—	—	—	—	IOCE3	MCLR V _{PP}
V _{DD}	11, 32	7, 28	7, 26	8, 28	—	—	—	—	—	—	—	—	—	—	—	—	—	—	—	—
V _{SS}	12, 31	6, 29	6, 27	6, 31, 30	—	—	—	—	—	—	—	—	—	—	—	—	—	—	—	—
OUT ⁽²⁾	—	—	—	—	ADGRDA ADGRDB	—	—	C1OUT C2OUT	—	SDO1 SCK1 SDO2 SCK2	TX/ CK ⁽³⁾ DT ⁽³⁾	DSM	TMR0	CCP1 CCP2 CCP3 CCP4 CCP5 PWM6OUT PWM7OUT	CWG1A CWG1B CWG1C CWG1D CWG2A CWG2B CWG2C CWG2D CWG3A CWG3B CWG3C CWG3D	CLC1OUT CLC2OUT CLC3OUT CLC4OUT	NCO	CLKR	—	—

- Note** 1: This is a PPS re-mappable input signal. The input function may be moved from the default location shown to one of several other PORTx pins. Refer to [Table 5](#) for details on which PORT pins may be used for this signal.
- 2: All output signals shown in this row are PPS re-mappable. These signals may be mapped to output onto one of several PORTx pin options as described in [Table 6](#).
- 3: This is a bidirectional signal. For normal module operation, the firmware should map this signal to the same pin in both the PPS input and PPS output registers.
- 4: These pins are configured for I²C™ logic levels.; The SCLx/SDAx signals may be assigned to any of the RB1/RB2/RC3/RC4 pins. PPS assignments to the other pins (e.g., RA5) will operate, but input logic levels will be standard TTL/ST, as selected by the INLVL register, instead of the I²C specific or SMBUS input buffer thresholds.

TABLE 5: PPS INPUT SIGNAL ROUTING OPTIONS DETAILS

Input Signal Name	Input Register Name	Default Location at POR	Re-mappable to any one of these PORTx pins		PPS Input Register Value to PORT Pin Mapping Reference Table	
			PIC16F1885X (28-Pin devices)	PIC16F1887X (40/44-Pin devices)	Desired Input Pin	Value to Write to Register ⁽¹⁾
INT	INTPPS	RB0	PORTA, PORTB	PORTA, PORTB	RA0	0x00
T0CKI	T0CKIPPS	RA4	PORTA, PORTB	PORTA, PORTB	RA1	0x01
T1CKI	T1CKIPPS	RC0	PORTA, PORTC	PORTA, PORTC	RA2	0x02
T1G	T1GPPS	RB5	PORTB, PORTC	PORTB, PORTC	RA3	0x03
T3CKI	T3CKIPPS	RC0	PORTB, PORTC	PORTB, PORTC	RA4	0x04
T3G	T3GPPS	RC0	PORTA, PORTC	PORTA, PORTC	RA5	0x05
T5CKI	T5CKIPPS	RC2	PORTA, PORTC	PORTA, PORTC	RA6	0x06
T5G	T5GPPS	RB4	PORTB, PORTC	PORTB, PORTD	RA7	0x07
T2IN	T2INPPS	RC3	PORTA, PORTC	PORTA, PORTC	RB0	0x08
T4IN	T4INPPS	RC5	PORTB, PORTC	PORTB, PORTC	RB1	0x09
T6IN	T6INPPS	RB7	PORTB, PORTC	PORTB, PORTD	RB2	0x0A
CCP1	CCP1PPS	RC2	PORTB, PORTC	PORTB, PORTC	RB3	0x0B
CCP2	CCP2PPS	RC1	PORTB, PORTC	PORTB, PORTC	RB4	0x0C
CCP3	CCP3PPS	RB5	PORTB, PORTC	PORTB, PORTD	RB5	0x0D
CCP4	CCP4PPS	RB0	PORTB, PORTC	PORTB, PORTD	RB6	0x0E
CCP5	CCP5PPS	RA4	PORTA, PORTC	PORTA, PORTE	RB7	0x0F
SMTWIN1	SMTWIN1PPS	RC0	PORTB, PORTC	PORTB, PORTC	RC0	0x10
SMTSIG1	SMTSIG1PPS	RC1	PORTB, PORTC	PORTB, PORTC	RC1	0x11
SMTWIN2	SMTWIN2PPS	RB4	PORTB, PORTC	PORTB, PORTD	RC2	0x12
SMTSIG2	SMTSIG2PPS	RB5	PORTB, PORTC	PORTB, PORTD	RC3	0x13
CWG1IN	CWG1PPS	RB0	PORTB, PORTC	PORTB, PORTD	RC4	0x14
CWG2IN	CWG2PPS	RB1	PORTB, PORTC	PORTB, PORTD	RC5	0x15
CWG3IN	CWG3PPS	RB2	PORTB, PORTC	PORTB, PORTD	RC6	0x16
MDCIN1	MDCIN1PPS	RA3	PORTA, PORTC	PORTA, PORTD	RC7	0x17
MDCIN2	MDCIN2PPS	RA4	PORTA, PORTC	PORTA, PORTD	RD0	0x18
MDMIN	MDMINPPS	RA5	PORTA, PORTC	PORTA, PORTD	RD1	0x19
CLCIN0	CLCIN0PPS	RA0	PORTA, PORTC	PORTA, PORTC	RD2	0x1A
CLCIN1	CLCIN1PPS	RA1	PORTB, PORTC	PORTA, PORTC	RD3	0x1B
CLCIN2	CLCIN2PPS	RB6	PORTB, PORTC	PORTB, PORTD	RD4	0x1C
CLCIN3	CLCIN3PPS	RB7	PORTB, PORTC	PORTB, PORTD	RD5	0x1D
ADCACT	ADCACTPPS	RB4	PORTB, PORTC	PORTB, PORTD	RD6	0x1E
SCK1/SCL1	SSP1CLKPPS	RC3	PORTB, PORTC	PORTB, PORTC	RD7	0x1F
SDI1/SDA1	SSP1DATPPS	RC4	PORTA, PORTC	PORTB, PORTC	RE0	0x20
SS1	SSPSS1PPS	RA5	PORTB, PORTC	PORTA, PORTD	RE1	0x21
SCK2/SCL2	SSP2CLKPPS	RB1	PORTB, PORTC	PORTB, PORTD	RE2	0x22
SDI2/SDA2	SSP2DATPPS	RB2	PORTB, PORTC	PORTB, PORTD	RE3	0x23
SS2	SSP2SSPPS	RB0	PORTB, PORTC	PORTB, PORTD		
RX/DT	RXPPS	RC7	PORTB, PORTC	PORTB PORTC		
TX/CK	CKPPS	RC6	PORTA, PORTB	PORTB PORTC		

Note 1: Only a few of the values in this column are valid for any given signal. For example, since the INT signal can only be mapped to PORTA or PORTB pins, only the register values 0x00-0x0F (corresponding to RA0-RA7 and RB0-RB7) are valid values to write to the INTPPS register.

PIC16(L)F1885X/7X

TABLE 6: PPS OUTPUT SIGNAL ROUTING OPTIONS

Output Signal Name	Re-mappable to any one of these PORTx pins		By writing this value to the Corresponding RxyPPS ⁽²⁾ Register
	PIC16F1885X (28-Pin devices)	PIC16F1887X (40/44-Pin devices)	
ADGRDB	PORTA, PORTC	PORTA, PORTC	0x25
ADGRDA	PORTA, PORTC	PORTA, PORTC	0x24
CWG3D	PORTA, PORTC	PORTA, PORTD	0x23
CWG3C	PORTA, PORTC	PORTA, PORTD	0x22
CWG3B	PORTA, PORTC	PORTA, PORTE ⁽¹⁾	0x21
CWG3A	PORTB, PORTC	PORTB, PORTC	0x20
CWG2D	PORTB, PORTC	PORTB, PORTD	0x1F
CWG2C	PORTB, PORTC	PORTB, PORTD	0x1E
CWG2B	PORTB, PORTC	PORTB, PORTD	0x1D
CWG2A	PORTB, PORTC	PORTB, PORTC	0x1C
DSM	PORTA, PORTC	PORTA, PORTD	0x1B
CLKR	PORTB, PORTC	PORTB, PORTC	0x1A
NCO	PORTA, PORTC	PORTA, PORTD	0x19
TMR0	PORTB, PORTC	PORTB, PORTC	0x18
SDO2/SDA2	PORTB, PORTC	PORTB, PORTD	0x17
SCK2/SCL2	PORTB, PORTC	PORTB, PORTD	0x16
SDO1/SDA1	PORTB, PORTC	PORTB, PORTC	0x15
SCK1/SCL1	PORTB, PORTC	PORTB, PORTC	0x14
C2OUT	PORTA, PORTC	PORTA, PORTE ⁽¹⁾	0x13
C1OUT	PORTA, PORTC	PORTA, PORTD	0x12
DT	PORTB, PORTC	PORTB, PORTC	0x11
TX/CK	PORTB, PORTC	PORTB, PORTC	0x10
PWM7OUT	PORTA, PORTC	PORTA, PORTC	0x0F
PWM6OUT	PORTA, PORTC	PORTA, PORTD	0x0E
CCP5	PORTA, PORTC	PORTA, PORTE ⁽¹⁾	0x0D
CCP4	PORTB, PORTC	PORTB, PORTD	0x0C
CCP3	PORTB, PORTC	PORTB, PORTD	0x0B
CCP2	PORTB, PORTC	PORTB, PORTC	0x0A
CCP1	PORTB, PORTC	PORTB, PORTC	0x09
CWG1D	PORTB, PORTC	PORTB, PORTD	0x08
CWG1C	PORTB, PORTC	PORTB, PORTD	0x07
CWG1B	PORTB, PORTC	PORTB, PORTD	0x06
CWG1A	PORTB, PORTC	PORTB, PORTC	0x05
CLC4OUT	PORTB, PORTC	PORTB, PORTD	0x04
CLC3OUT	PORTB, PORTC	PORTB, PORTD	0x03
CLC2OUT	PORTA, PORTC	PORTA, PORTC	0x02
CLC1OUT	PORTA, PORTC	PORTA, PORTC	0x01

Note 1: RE3 is an input-only pin. Therefore, this signal may only be mapped to RE0, RE1 or RE2 (or a PORTA pin).

2: In "RxyPPS", the "x" is a PORT letter (e.g., "C"), and the "y" is a port pin number (e.g., "6"). For example, to map the UART TX/CK signal to output onto RC6, write 0x10 to the RC6PPS register.

Note the following details of the code protection feature on Microchip devices:

- Microchip products meet the specification contained in their particular Microchip Data Sheet.
- Microchip believes that its family of products is one of the most secure families of its kind on the market today, when used in the intended manner and under normal conditions.
- There are dishonest and possibly illegal methods used to breach the code protection feature. All of these methods, to our knowledge, require using the Microchip products in a manner outside the operating specifications contained in Microchip's Data Sheets. Most likely, the person doing so is engaged in theft of intellectual property.
- Microchip is willing to work with the customer who is concerned about the integrity of their code.
- Neither Microchip nor any other semiconductor manufacturer can guarantee the security of their code. Code protection does not mean that we are guaranteeing the product as “unbreakable.”

Code protection is constantly evolving. We at Microchip are committed to continuously improving the code protection features of our products. Attempts to break Microchip's code protection feature may be a violation of the Digital Millennium Copyright Act. If such acts allow unauthorized access to your software or other copyrighted work, you may have a right to sue for relief under that Act.

Information contained in this publication regarding device applications and the like is provided only for your convenience and may be superseded by updates. It is your responsibility to ensure that your application meets with your specifications. MICROCHIP MAKES NO REPRESENTATIONS OR WARRANTIES OF ANY KIND WHETHER EXPRESS OR IMPLIED, WRITTEN OR ORAL, STATUTORY OR OTHERWISE, RELATED TO THE INFORMATION, INCLUDING BUT NOT LIMITED TO ITS CONDITION, QUALITY, PERFORMANCE, MERCHANTABILITY OR FITNESS FOR PURPOSE. Microchip disclaims all liability arising from this information and its use. Use of Microchip devices in life support and/or safety applications is entirely at the buyer's risk, and the buyer agrees to defend, indemnify and hold harmless Microchip from any and all damages, claims, suits, or expenses resulting from such use. No licenses are conveyed, implicitly or otherwise, under any Microchip intellectual property rights.

Trademarks

The Microchip name and logo, the Microchip logo, dsPIC, FlashFlex, flexPWR, JukeBlox, KEELOQ, KEELOQ logo, Klear, LANCheck, MediaLB, MOST, MOST logo, MPLAB, OptoLyzer, PIC, PICSTART, PIC³² logo, RightTouch, SpyNIC, SST, SST Logo, SuperFlash and UNI/O are registered trademarks of Microchip Technology Incorporated in the U.S.A. and other countries.

The Embedded Control Solutions Company and mTouch are registered trademarks of Microchip Technology Incorporated in the U.S.A.

Analog-for-the-Digital Age, BodyCom, chipKIT, chipKIT logo, CodeGuard, dsPICDEM, dsPICDEM.net, ECAN, In-Circuit Serial Programming, ICSP, Inter-Chip Connectivity, KlearNet, KlearNet logo, MiWi, MPASM, MPF, MPLAB Certified logo, MPLIB, MPLINK, MultiTRAK, NetDetach, Omniscient Code Generation, PICDEM, PICDEM.net, PICkit, PICtail, RightTouch logo, REAL ICE, SQI, Serial Quad I/O, Total Endurance, TSHARC, USBCheck, VariSense, ViewSpan, WiperLock, Wireless DNA, and ZENA are trademarks of Microchip Technology Incorporated in the U.S.A. and other countries.

SQTP is a service mark of Microchip Technology Incorporated in the U.S.A.

Silicon Storage Technology is a registered trademark of Microchip Technology Inc. in other countries.

GestIC is a registered trademarks of Microchip Technology Germany II GmbH & Co. KG, a subsidiary of Microchip Technology Inc., in other countries.

All other trademarks mentioned herein are property of their respective companies.

© 2014, Microchip Technology Incorporated, Printed in the U.S.A., All Rights Reserved.

ISBN: 978-1-63276-622-9

QUALITY MANAGEMENT SYSTEM
CERTIFIED BY DNV
== ISO/TS 16949 ==

Microchip received ISO/TS-16949:2009 certification for its worldwide headquarters, design and wafer fabrication facilities in Chandler and Tempe, Arizona; Gresham, Oregon and design centers in California and India. The Company's quality system processes and procedures are for its PIC® MCUs and dsPIC® DSCs, KEELOQ® code hopping devices, Serial EEPROMs, microperipherals, nonvolatile memory and analog products. In addition, Microchip's quality system for the design and manufacture of development systems is ISO 9001:2000 certified.



MICROCHIP

Worldwide Sales and Service

AMERICAS

Corporate Office

2355 West Chandler Blvd.
Chandler, AZ 85224-6199
Tel: 480-792-7200
Fax: 480-792-7277
Technical Support:
<http://www.microchip.com/support>
Web Address:
www.microchip.com

Atlanta

Duluth, GA
Tel: 678-957-9614
Fax: 678-957-1455

Austin, TX

Tel: 512-257-3370

Boston

Westborough, MA
Tel: 774-760-0087
Fax: 774-760-0088

Chicago

Itasca, IL
Tel: 630-285-0071
Fax: 630-285-0075

Cleveland

Independence, OH
Tel: 216-447-0464
Fax: 216-447-0643

Dallas

Addison, TX
Tel: 972-818-7423
Fax: 972-818-2924

Detroit

Novi, MI
Tel: 248-848-4000

Houston, TX

Tel: 281-894-5983

Indianapolis

Noblesville, IN
Tel: 317-773-8323
Fax: 317-773-5453

Los Angeles

Mission Viejo, CA
Tel: 949-462-9523
Fax: 949-462-9608

New York, NY

Tel: 631-435-6000

San Jose, CA

Tel: 408-735-9110

Canada - Toronto

Tel: 905-673-0699
Fax: 905-673-6509

ASIA/PACIFIC

Asia Pacific Office

Suites 3707-14, 37th Floor
Tower 6, The Gateway
Harbour City, Kowloon
Hong Kong
Tel: 852-2943-5100
Fax: 852-2401-3431

Australia - Sydney

Tel: 61-2-9868-6733
Fax: 61-2-9868-6755

China - Beijing

Tel: 86-10-8569-7000
Fax: 86-10-8528-2104

China - Chengdu

Tel: 86-28-8665-5511
Fax: 86-28-8665-7889

China - Chongqing

Tel: 86-23-8980-9588
Fax: 86-23-8980-9500

China - Hangzhou

Tel: 86-571-8792-8115
Fax: 86-571-8792-8116

China - Hong Kong SAR

Tel: 852-2943-5100
Fax: 852-2401-3431

China - Nanjing

Tel: 86-25-8473-2460
Fax: 86-25-8473-2470

China - Qingdao

Tel: 86-532-8502-7355
Fax: 86-532-8502-7205

China - Shanghai

Tel: 86-21-5407-5533
Fax: 86-21-5407-5066

China - Shenyang

Tel: 86-24-2334-2829
Fax: 86-24-2334-2393

China - Shenzhen

Tel: 86-755-8864-2200
Fax: 86-755-8203-1760

China - Wuhan

Tel: 86-27-5980-5300
Fax: 86-27-5980-5118

China - Xian

Tel: 86-29-8833-7252
Fax: 86-29-8833-7256

China - Xiamen

Tel: 86-592-2388138
Fax: 86-592-2388130

China - Zhuhai

Tel: 86-756-3210040
Fax: 86-756-3210049

ASIA/PACIFIC

India - Bangalore

Tel: 91-80-3090-4444
Fax: 91-80-3090-4123

India - New Delhi

Tel: 91-11-4160-8631
Fax: 91-11-4160-8632

India - Pune

Tel: 91-20-3019-1500

Japan - Osaka

Tel: 81-6-6152-7160
Fax: 81-6-6152-9310

Japan - Tokyo

Tel: 81-3-6880-3770
Fax: 81-3-6880-3771

Korea - Daegu

Tel: 82-53-744-4301
Fax: 82-53-744-4302

Korea - Seoul

Tel: 82-2-554-7200
Fax: 82-2-558-5932 or
82-2-558-5934

Malaysia - Kuala Lumpur

Tel: 60-3-6201-9857
Fax: 60-3-6201-9859

Malaysia - Penang

Tel: 60-4-227-8870
Fax: 60-4-227-4068

Philippines - Manila

Tel: 63-2-634-9065
Fax: 63-2-634-9069

Singapore

Tel: 65-6334-8870
Fax: 65-6334-8850

Taiwan - Hsin Chu

Tel: 886-3-5778-366
Fax: 886-3-5770-955

Taiwan - Kaohsiung

Tel: 886-7-213-7830

Taiwan - Taipei

Tel: 886-2-2508-8600
Fax: 886-2-2508-0102

Thailand - Bangkok

Tel: 66-2-694-1351
Fax: 66-2-694-1350

EUROPE

Austria - Wels

Tel: 43-7242-2244-39
Fax: 43-7242-2244-393

Denmark - Copenhagen

Tel: 45-4450-2828
Fax: 45-4485-2829

France - Paris

Tel: 33-1-69-53-63-20
Fax: 33-1-69-30-90-79

Germany - Dusseldorf

Tel: 49-2129-3766400

Germany - Munich

Tel: 49-89-627-144-0
Fax: 49-89-627-144-44

Germany - Pforzheim

Tel: 49-7231-424750

Italy - Milan

Tel: 39-0331-742611
Fax: 39-0331-466781

Italy - Venice

Tel: 39-049-7625286

Netherlands - Drunen

Tel: 31-416-690399
Fax: 31-416-690340

Poland - Warsaw

Tel: 48-22-3325737

Spain - Madrid

Tel: 34-91-708-08-90
Fax: 34-91-708-08-91

Sweden - Stockholm

Tel: 46-8-5090-4654

UK - Wokingham

Tel: 44-118-921-5800
Fax: 44-118-921-5820

03/25/14