

Chipsmall Limited consists of a professional team with an average of over 10 year of expertise in the distribution of electronic components. Based in Hongkong, we have already established firm and mutual-benefit business relationships with customers from,Europe,America and south Asia,supplying obsolete and hard-to-find components to meet their specific needs.

With the principle of “Quality Parts,Customers Priority,Honest Operation,and Considerate Service”,our business mainly focus on the distribution of electronic components. Line cards we deal with include Microchip,ALPS,ROHM,Xilinx,Pulse,ON,Everlight and Freescale. Main products comprise IC,Modules,Potentiometer,IC Socket,Relay,Connector.Our parts cover such applications as commercial,industrial, and automotives areas.

We are looking forward to setting up business relationship with you and hope to provide you with the best service and solution. Let us make a better world for our industry!



## Contact us

Tel: +86-755-8981 8866 Fax: +86-755-8427 6832

Email & Skype: [info@chipsmall.com](mailto:info@chipsmall.com) Web: [www.chipsmall.com](http://www.chipsmall.com)

Address: A1208, Overseas Decoration Building, #122 Zhenhua RD., Futian, Shenzhen, China

---

---

## 28-Pin 8-Bit Advanced Analog Flash Microcontroller

---

---

### High-Performance RISC CPU:

- Only 49 Instructions
- Operating Speed:
  - DC – 32 MHz clock input
  - DC – 125 ns instruction cycle
- Interrupt Capability with Automatic Context Saving
- 16-Level Deep Hardware Stack with optional Overflow/Underflow Reset
- Direct, Indirect and Relative Addressing modes:
- Two full 16-bit File Select Registers (FSRs)
  - FSRs can read program and data memory

### Memory Features:

- Up to 16 KW Flash Program Memory:
  - Self-programmable under software control
  - Programmable code protection
  - Programmable write protection
- 256 Bytes of Data EEPROM
- Up to 2048 Bytes of RAM

### High-Performance PWM Controller:

- Four Programmable Switch Mode Controller (PSMC) modules:
  - Digital and/or analog feedback control of PWM frequency and pulse begin/end times
  - 16-bit Period, Duty Cycle and Phase
  - 16 ns clock resolution
  - Supports Single PWM, Complementary, Push-Pull and 3-phase modes of operation
  - Dead-band control with 8-bit counter
  - Auto-shutdown and restart
  - Leading and falling edge blanking
  - Burst mode

### Extreme Low-Power Management PIC16LF1788/9 with XLP:

- Sleep mode: 50 nA @ 1.8V, typical
- Watchdog Timer: 500 nA @ 1.8V, typical
- Timer1 Oscillator: 500 nA @ 32 kHz
- Operating Current:
  - 8  $\mu$ A @ 32 kHz, 1.8V, typical
  - 32  $\mu$ A/MHz @ 1.8V, typical

### Analog Peripheral Features:

- Analog-to-Digital Converter (ADC):
  - Fully differential 12-bit converter
  - Up to 75 ksps conversion rate
  - 11 single-ended channels
  - 5 differential channels
  - Positive and negative reference selection
- One 8-Bit and Three 5-Bit Digital-to-Analog Converters (DAC):
  - Output available externally
  - Positive and negative reference selection
  - Internal connections to comparators, op amps, Fixed Voltage Reference (FVR) and ADC
- Four High-Speed Comparators:
  - 50 ns response time @  $V_{DD} = 5V$
  - Rail-to-rail inputs
  - Software selectable hysteresis
  - Internal connection to op amps, FVR and DAC
- Up to Three Operational Amplifiers:
  - Rail-to-rail inputs/outputs
  - High/Low selectable Gain Bandwidth Product
  - Internal connection to DAC and FVR
- Fixed Voltage Reference (FVR):
  - 1.024V, 2.048V and 4.096V output levels
  - Internal connection to ADC, comparators and DAC

### I/O Features:

- Up to 36 I/O Pins and 1 Input-only Pin:
- High Current Sink/Source for LED Drivers
- Individually Programmable Interrupt-on-Change Pins
- Individually Programmable Weak Pull-Ups
- Individual Input Level Selection
- Individually Programmable Slew Rate Control
- Individually Programmable Open-Drain Outputs

# PIC16(L)F1788/9

---

## Digital Peripheral Features:

- Timer0: 8-Bit Timer/Counter with 8-Bit Programmable Prescaler
- Enhanced Timer1:
  - 16-bit timer/counter with prescaler
  - External Gate Input mode
  - Dedicated low-power 32 kHz oscillator driver
- Timer2: 8-Bit Timer/Counter with 8-Bit Period Register, Prescaler and Postscaler
- Two Capture/Compare/PWM modules (CCP):
  - 16-bit capture, maximum resolution 12.5 ns
  - 16-bit compare, max resolution 31.25 ns
  - 10-bit PWM, max frequency 32 kHz
- Master Synchronous Serial Port (SSP) with SPI and I<sup>2</sup>C with:
  - 7-bit address masking
  - SMBus/PMBus™ compatibility
- Enhanced Universal Synchronous Asynchronous Receiver Transmitter (EUSART):
  - RS-232, RS-485 and LIN compatible
  - Auto-baud detect
  - Auto-wake-up on start

## Oscillator Features:

- Operate up to 32 MHz from Precision Internal Oscillator:
  - Factory calibrated to ±1%, typical
  - Software selectable frequency range from 32 MHz to 31 kHz
- 31 kHz Low-Power Internal Oscillator
- 32.768 kHz Timer1 Oscillator:
  - Available as system clock
  - Low-power RTC
- External Oscillator Block with:
  - 4 crystal/resonator modes up to 32 MHz using 4x PLL
  - 3 external clock modes up to 32 MHz
- 4x Phase-Locked Loop (PLL)
- Fail-Safe Clock Monitor:
  - Detect and recover from external oscillator failure
- Two-Speed Start-up:
  - Minimize latency between code execution and external oscillator start-up

## General Microcontroller Features:

- Power-Saving Sleep mode
- Power-on Reset (POR)
- Power-up Timer (PWRT)
- Oscillator Start-up Timer (OST)
- Brown-out Reset (BOR) with Selectable Trip Point
- Extended Watchdog Timer (WDT)
- In-Circuit Serial Programming™ (ICSP™)
- In-Circuit Debug (ICD)
- Enhanced Low-Voltage Programming (LVP)
- Operating Voltage Range:
  - 1.8V to 3.6V (PIC16LF1788/9)
  - 2.3V to 5.5V (PIC16F1788/9)

## PIC16(L)F178X Family Types

Device	Data Sheet Index	Program Memory Flash (words)	Data EEPROM (bytes)	Data SRAM (bytes)	I/O's <sup>(2)</sup>	12-bit ADC (ch)	Comparators	Operational Amplifiers	DAC (8/5-bit)	Timers (8/16-bit)	Programmable Switch Mode Controllers (PSMC)	CCP	EUSART	MSSP (I <sup>2</sup> C/SPI)	Debug <sup>(1)</sup>	XLP
PIC16(L)F1782	(1)	2048	256	256	25	11	3	2	1/0	2/1	2	2	1	1	I	Y
PIC16(L)F1783	(1)	4096	256	512	25	11	3	2	1/0	2/1	2	2	1	1	I	Y
PIC16(L)F1784	(2)	4096	256	512	36	15	4	3	1/0	2/1	3	3	1	1	I	Y
PIC16(L)F1786	(2)	8192	256	1024	25	11	4	2	1/0	2/1	3	3	1	1	I	Y
PIC16(L)F1787	(2)	8192	256	1024	36	15	4	3	1/0	2/1	3	3	1	1	I	Y
PIC16(L)F1788	(3)	16384	256	2048	25	11	4	2	1/3	2/1	4	3	1	1	I	Y
PIC16(L)F1789	(3)	16384	256	2048	36	15	4	3	1/3	2/1	4	3	1	1	I	Y

**Note 1:** I - Debugging, Integrated on Chip; H - Debugging, available using Debug Header.

**2:** One pin is input-only.

**Data Sheet Index:** (Unshaded devices are described in this document.)

- 1: DS40001579 [PIC16\(L\)F1782/3 Data Sheet, 28-Pin Flash, 8-bit Advanced Analog MCUs.](#)
- 2: DS40001637 [PIC16\(L\)F1784/6/7 Data Sheet, 28/40/44-Pin Flash, 8-bit Advanced Analog MCUs.](#)
- 3: DS40001675 [PIC16\(L\)F1788/9 Data Sheet, 28/40/44-Pin Flash, 8-bit Advanced Analog MCUs.](#)

**Note:** For other small form-factor package availability and marking information, please visit <http://www.microchip.com/packaging> or contact your local sales office.

# PIC16(L)F1788/9

## Pin Diagram – 28-Pin SPDIP, SOIC, SSOP

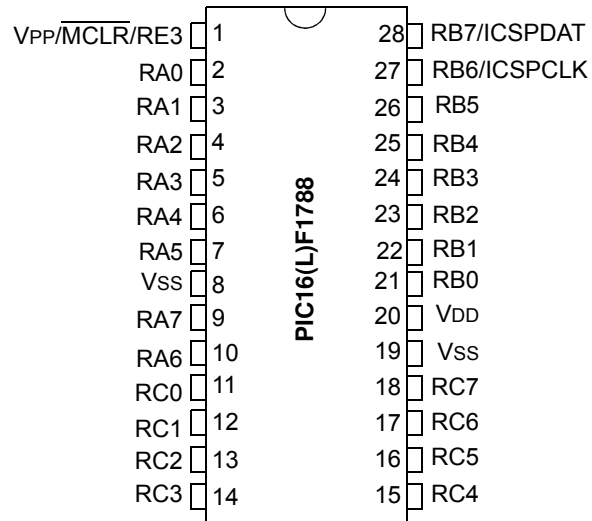

**Note:** See [Table 1](#) for the location of all peripheral functions.

## Pin Diagram – 28-Pin QFN

QFN

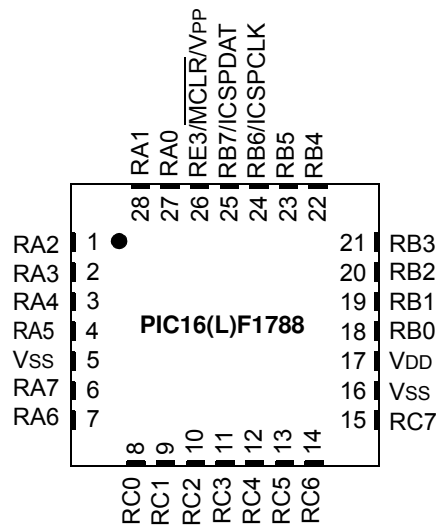

**Note:** See [Table 1](#) for the location of all peripheral functions.

## Pin Diagram – 40-Pin PDIP

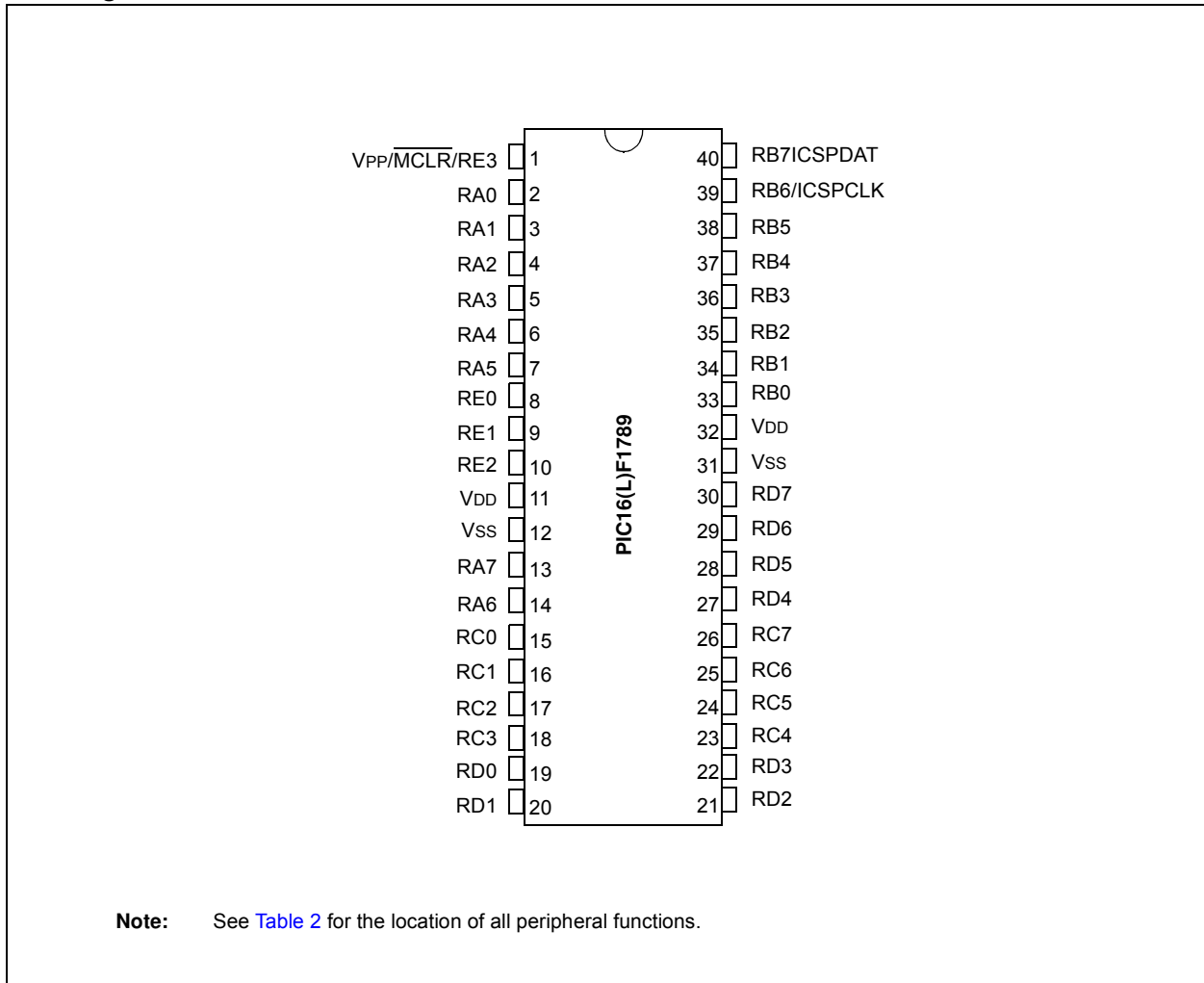

# PIC16(L)F1788/9

## Pin Diagram – 40-Pin UQFN (5x5)

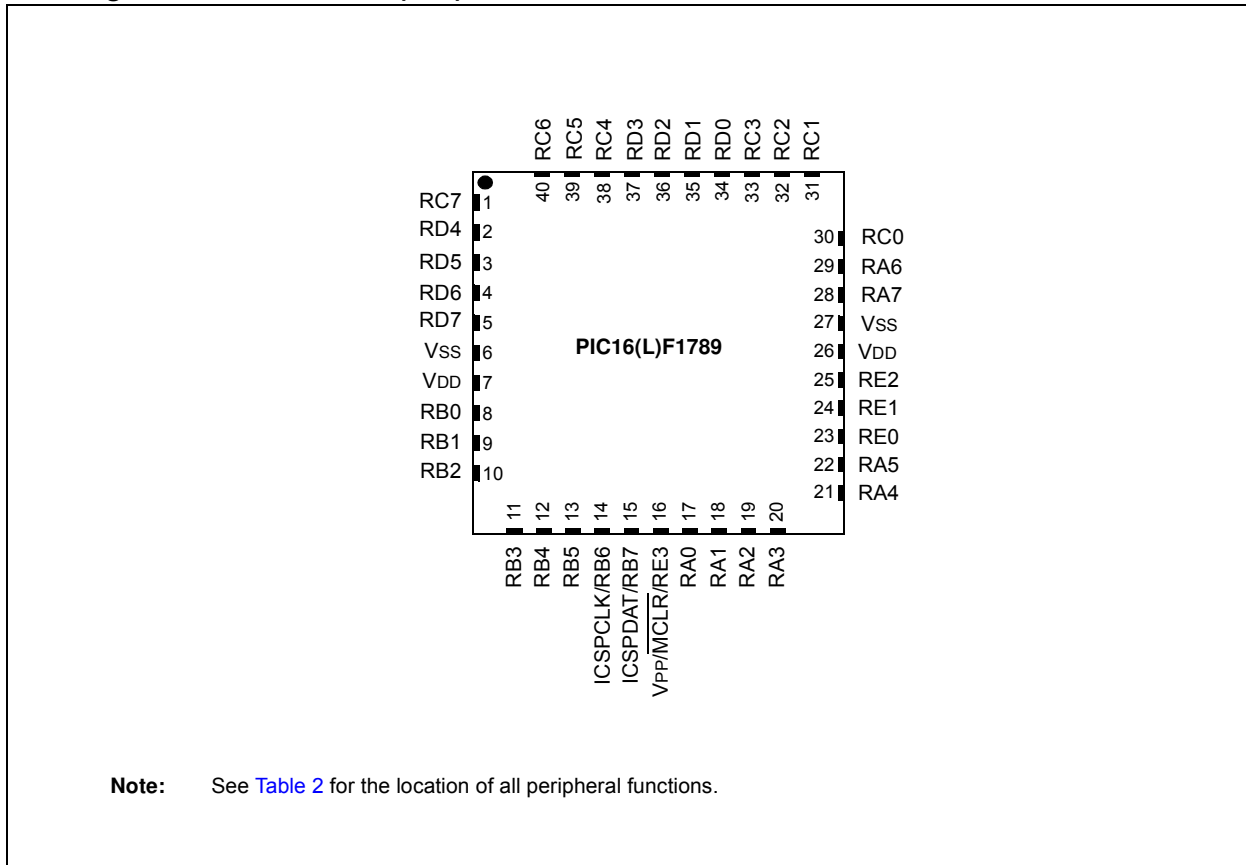

**Note:** See [Table 2](#) for the location of all peripheral functions.

## Pin Diagram – 44-Pin QFN

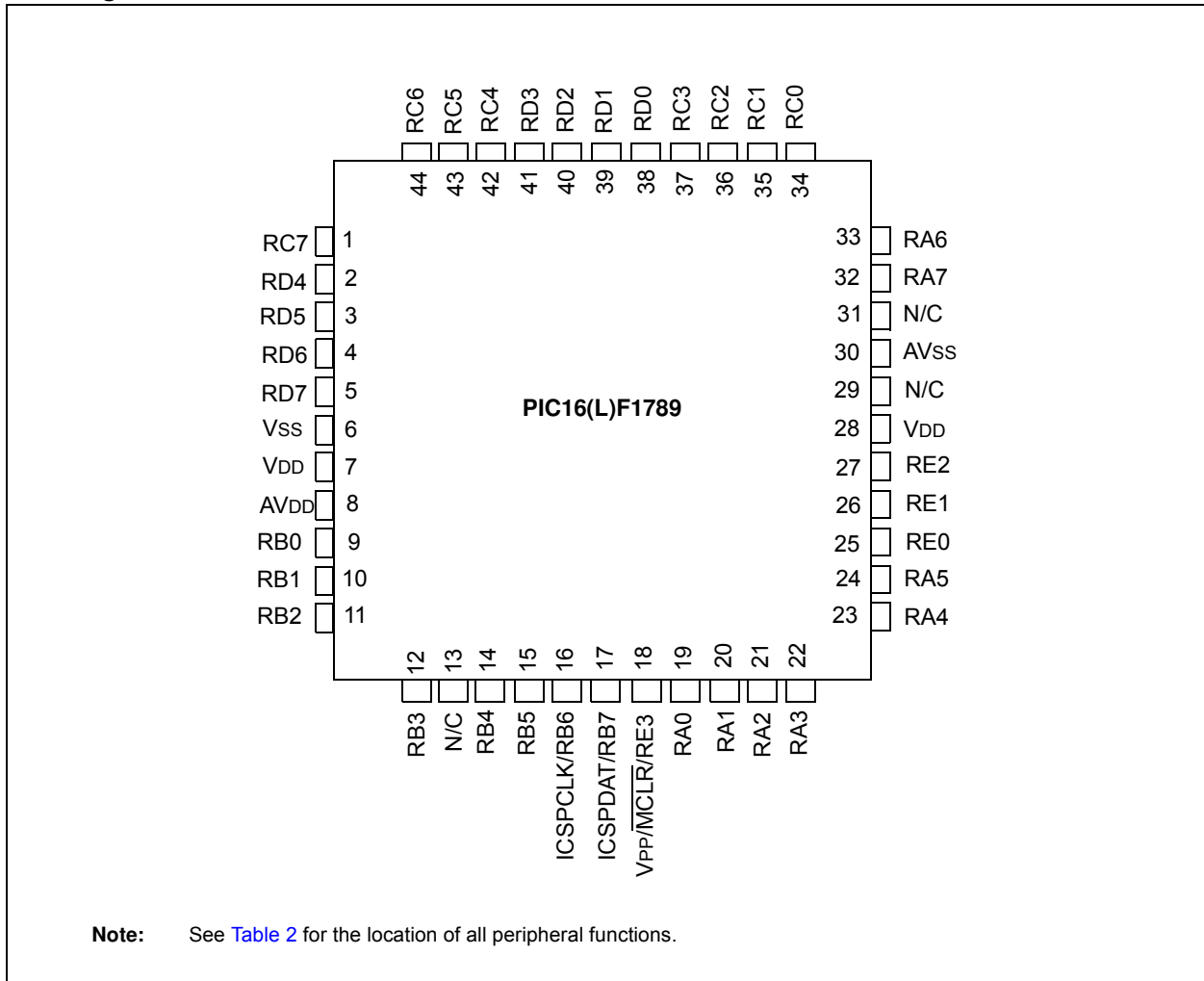



# PIC16(L)F1788/9

## Pin Diagram – 44-Pin TQFP

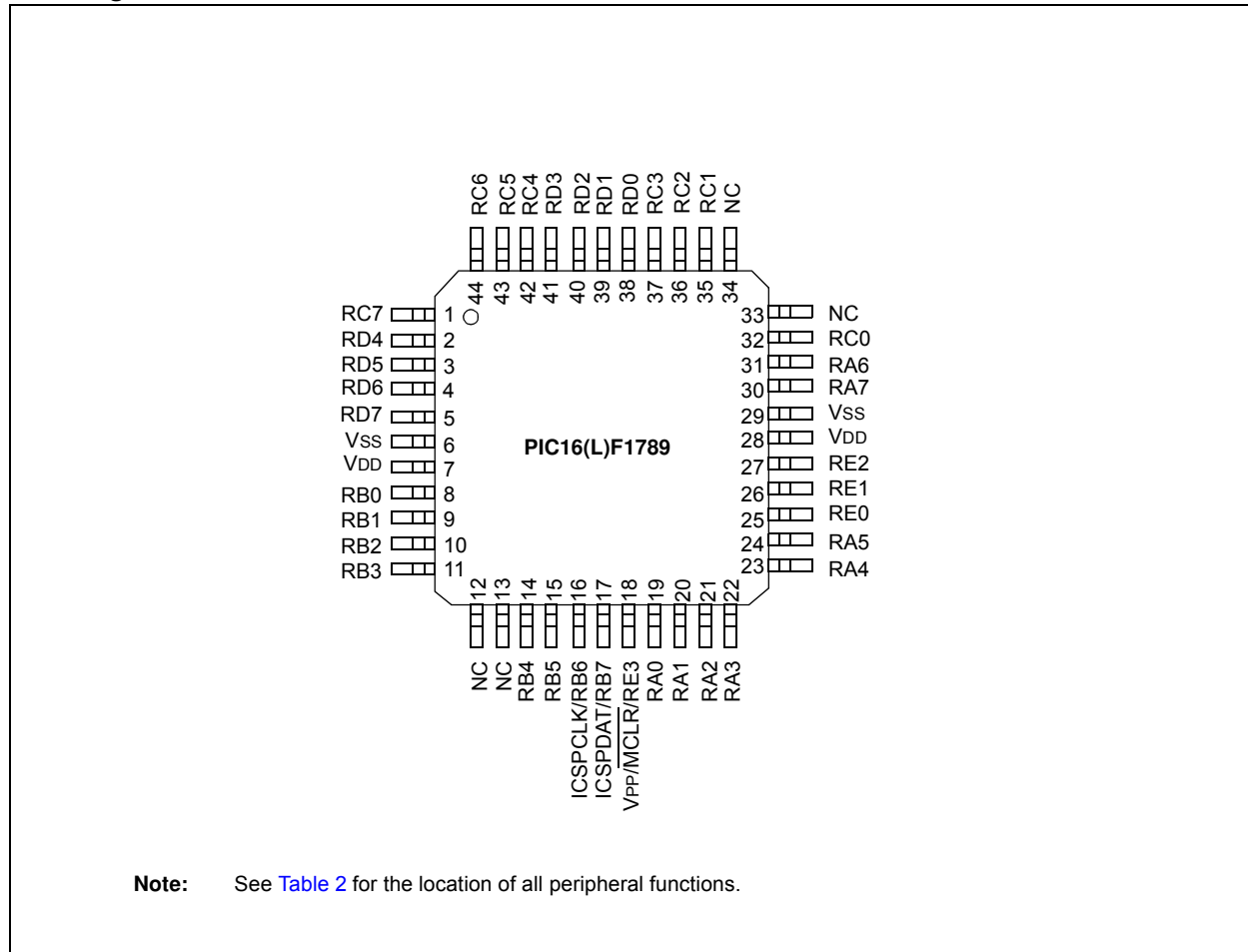

## PIN ALLOCATION TABLE

**TABLE 1: 28-PIN ALLOCATION TABLE (PIC16(L)F1788)**

I/O	28-Pin SPDIP, SOIC, SSOP	28-Pin QFN,	ADC	Reference	Comparator	Operation Amplifiers	8-bit/ 5-bit DAC	Timers	PSMC	CCP	EUSART	MSSP	Interrupt	Pull-up	Basic
RA0	2	27	AN0	—	C1IN0- C2IN0- C3IN0- C4IN0-	—	—	—	—	—	—	SS <sup>(1)</sup>	IOC	Y	—
RA1	3	28	AN1	—	C1IN1- C2IN1- C3IN1- C4IN1-	OPA1OUT	—	—	—	—	—	—	IOC	Y	—
RA2	4	1	AN2	VREF- DAC1VREF-	C1IN0+ C2IN0+ C3IN0+ C4IN0+	—	DAC1OUT1	—	—	—	—	—	IOC	Y	—
RA3	5	2	AN3	VREF+ DAC1VREF+ DAC2VREF+ DAC3VREF+ DAC4VREF+	C1IN1+	—	—	—	—	—	—	—	IOC	Y	—
RA4	6	3	—	—	C1OUT	OPA1IN+	DAC4OUT1	T0CKI	—	—	—	—	IOC	Y	—
RA5	7	4	AN4	—	C2OUT	OPA1IN-	DAC2OUT1	—	—	—	—	SS	IOC	Y	—
RA6	10	7	—	—	C2OUT <sup>(1)</sup>	—	—	—	—	—	—	—	IOC	Y	Vcap OSC2 CLKOUT
RA7	9	6	—	—	—	—	—	—	PSMC1CLK PSMC2CLK PSMC3CLK PSMC4CLK	—	—	—	IOC	Y	CLKIN OSC1
RB0	21	18	AN12	—	C2IN1+	—	—	—	PSMC1IN PSMC2IN PSMC3IN PSMC4IN	CCP1 <sup>(1)</sup>	—	—	INT IOC	Y	—
RB1	22	19	AN10	—	C1IN3- C2IN3- C3IN3- C4IN3-	OPA2OUT	—	—	—	—	—	—	IOC	Y	—
RB2	23	20	AN8	—	—	OPA2IN-	DAC3OUT1	—	—	—	—	—	IOC	Y	CLKR
RB3	24	21	AN9	—	C1IN2- C2IN2- C3IN2-	OPA2IN+	—	—	—	CCP2 <sup>(1)</sup>	—	—	IOC	Y	—
RB4	25	22	AN11	—	C3IN1+	—	—	—	—	—	—	SS <sup>(1)</sup>	IOC	Y	—
RB5	26	23	AN13	—	C4IN2- C3OUT	—	—	T1G	—	CCP3 <sup>(1)</sup>	—	SDO <sup>(1)</sup>	IOC	Y	—
RB6	27	24	—	—	C4IN1+	—	—	—	—	—	TX <sup>(1)</sup> CK <sup>(1)</sup>	SDI <sup>(1)</sup> SDA <sup>(1)</sup>	IOC	Y	ICSPCLK
RB7	28	25	—	—	—	—	DAC1OUT2 DAC2OUT2 DAC3OUT2 DAC4OUT2	—	—	—	RX <sup>(1)</sup> DT <sup>(1)</sup>	SCK <sup>(1)</sup> SCL <sup>(1)</sup>	IOC	Y	ICSPDAT
RC0	11	8	—	—	—	—	—	T1CKI T1OSO	PSMC1A	—	—	—	IOC	Y	—
RC1	12	9	—	—	—	—	—	T1OSI	PSMC1B	CCP2	—	—	IOC	Y	—
RC2	13	10	—	—	—	—	—	—	PSMC1C PSMC3B	CCP1	—	—	IOC	Y	—
RC3	14	11	—	—	—	—	—	—	PSMC1D PSMC4A	—	—	SCK SCL	IOC	Y	—
RC4	15	12	—	—	—	—	—	—	PSMC1E PSMC4B	—	—	SDI SDA	IOC	Y	—
RC5	16	13	—	—	—	—	—	—	PSMC1F PSMC3A	—	—	SDO	IOC	Y	—

**Note 1:** Alternate pin function selected with the APFCON1 (Register 13-1) and APFCON2 (Register 13-2) registers.

# PIC16(L)F1788/9

**TABLE 1: 28-PIN ALLOCATION TABLE (PIC16(L)F1788) (Continued)**

I/O	28-Pin SPDIP, SOIC, SSOP	28-Pin QFN,	ADC	Reference	Comparator	Operation Amplifiers	8-bit/ 5-bit DAC	Timers	PSMC	CCP	EUSART	MSSP	Interrupt	Pull-up	Basic
RC6	17	14	—	—	—	—	—	—	PSMC2A	CCP3	TX CK	—	IOC	Y	—
RC7	18	15	—	—	C4OUT	—	—	—	PSMC2B	—	RX DT	—	IOC	Y	—
RE3	1	26	—	—	—	—	—	—	—	—	—	—	IOC	Y	MCLR VPP
VDD	20	17	—	—	—	—	—	—	—	—	—	—	—	—	VDD
VSS	8, 19	5, 16	—	—	—	—	—	—	—	—	—	—	—	—	VSS

**Note 1:** Alternate pin function selected with the APFCON1 ([Register 13-1](#)) and APFCON2 ([Register 13-2](#)) registers.

# PIC16(L)F1788/9

**TABLE 2: 40/44-PIN ALLOCATION TABLE (PIC16(L)F1789)**

I/O	40-Pin PDIP	40-Pin UQFN	44-Pin TQFP	44-Pin QFN	ADC	Reference	Comparator	Op Amps	8-bit/ 5-bit DAC	Timers	PSMC	CCP	EUSART	MSSP	Interrupt	Pull-up	Basic
RA0	2	17	19	19	AN0	—	C1IN0- C2IN0- C3IN0- C4IN0-	—	—	—	—	—	—	SS <sup>(1)</sup>	IOC	Y	—
RA1	3	18	20	20	AN1	—	C1IN1- C2IN1- C3IN1- C4IN1-	OPA1OUT	—	—	—	—	—	—	IOC	Y	—
RA2	4	19	21	21	AN2	DAC1VREF- VREF-	C1IN0+ C2IN0+ C3IN0+ C4IN0+	—	DAC1OUT1	—	—	—	—	—	IOC	Y	—
RA3	5	20	22	22	AN3	VREF+ DAC1VREF+ DAC2VREF+ DAC3VREF+ DAC4VREF+	C1IN1+	—	—	—	—	—	—	—	IOC	Y	—
RA4	6	21	23	23	—	—	C1OUT	OPA1IN+	—	T0CKI	—	—	—	—	IOC	Y	—
RA5	7	22	24	24	AN4	—	C2OUT	OPA1IN-	DAC2OUT1	—	—	—	—	SS	IOC	Y	—
RA6	14	29	31	33	—	—	C2OUT <sup>(1)</sup>	—	—	—	—	—	—	—	IOC	Y	VCAP CLKOUT OSC2
RA7	13	28	30	32	—	—	—	—	—	—	PSMC1CLK PSMC2CLK PSMC3CLK PSMC4CLK	—	—	—	IOC	Y	CLKIN OSC1
RB0	33	8	8	9	AN12	—	C2IN1+	—	—	—	PSMC1IN PSMC2IN PSMC3IN PSMC4IN	CCP1 <sup>(1)</sup>	—	—	INT IOC	Y	—
RB1	34	9	9	10	AN10	—	C1IN3- C2IN3- C3IN3- C4IN3-	OPA2OUT	—	—	—	—	—	—	IOC	Y	—
RB2	35	10	10	11	AN8	—	—	OPA2IN-	DAC3OUT1	—	—	—	—	—	IOC	Y	CLKR
RB3	36	11	11	12	AN9	—	C1IN2- C2IN2- C3IN2-	OPA2IN+	—	—	—	CCP2 <sup>(1)</sup>	—	—	IOC	Y	—
RB4	37	12	14	14	AN11	—	C3IN1+	—	—	—	—	—	—	SS <sup>(1)</sup>	IOC	Y	—
RB5	38	13	15	15	AN13	—	C4IN2-	—	—	T1G	—	CCP3 <sup>(1)</sup>	—	SDO <sup>(1)</sup>	IOC	Y	—
RB6	39	14	16	16	—	—	C4IN1+	—	—	—	—	—	TX <sup>(1)</sup> CK <sup>(1)</sup>	SDA <sup>(1)</sup> SDI <sup>(1)</sup>	IOC	Y	ICSPCLK
RB7	40	15	17	17	—	—	—	—	DAC1OUT2 DAC2OUT2- DAC3OUT2- DAC4OUT2	—	—	—	RX <sup>(1)</sup> DT <sup>(1)</sup>	SCL <sup>(1)</sup> SCK <sup>(1)</sup>	IOC	Y	ICSPDAT
RC0	15	30	32	34	—	—	—	—	—	T1CKI T1OSO	PSMC1A	—	—	—	IOC	Y	—
RC1	16	31	35	35	—	—	—	—	—	—	PSMC1B	CCP2	—	—	IOC	Y	—
RC2	17	32	36	36	—	—	—	—	—	—	PSMC1C	CCP1	—	—	IOC	Y	—
RC3	18	33	37	37	—	—	—	—	—	—	PSMC1D	—	—	SCL SCK	IOC	Y	—
RC4	23	38	42	42	—	—	—	—	—	—	PSMC1E	—	—	SDI SDA	IOC	Y	—
RC5	24	39	43	43	—	—	—	—	—	—	PSMC1F	—	—	SDO	IOC	Y	—
RC6	25	40	44	44	—	—	—	—	—	—	PSMC2A	—	TX CK	—	IOC	Y	—
RC7	26	1	1	1	—	—	—	—	—	—	PSMC2B	—	RX DT	—	IOC	Y	—
RD0	19	34	38	38	—	—	—	OPA3IN+	—	—	—	—	—	—	—	Y	—

**Note 1:** Alternate pin function selected with the APFCON1 (Register 13-1) and APFCON2 (Register 13-2) registers.

# PIC16(L)F1788/9

**TABLE 2: 40/44-PIN ALLOCATION TABLE (PIC16(L)F1789) (Continued)**

I/O	40-Pin PDIP	40-Pin UQFN	44-Pin TQFP	44-Pin QFN	ADC	Reference	Comparator	Op Amps	8-bit/ 5-bit DAC	Timers	PSMC	CCP	EUSART	MSSP	Interrupt	Pull-up	Basic
RD1	20	35	39	39	AN21	—	C1IN4- C2IN4- C3IN4- C4IN4-	OPA3OUT	—	—	—	—	—	—	—	Y	—
RD2	21	36	40	40	—	—	—	OPA3IN-	DAC4OUT1	—	—	—	—	—	—	Y	—
RD3	22	37	41	41	—	—	—	—	—	—	PSMC4A	—	—	—	—	Y	—
RD4	27	2	2	2	—	—	—	—	—	—	PSMC3F	—	—	—	—	Y	—
RD5	28	3	3	3	—	—	—	—	—	—	PSMC3E	—	—	—	—	Y	—
RD6	29	4	4	4	—	—	C3OUT	—	—	—	PSMC3D	—	—	—	—	Y	—
RD7	30	5	5	5	—	—	C4OUT	—	—	—	PSMC3C	—	—	—	—	Y	—
RE0	8	23	25	25	AN5	—	—	—	—	—	PSMC4B	CCP3	—	—	—	Y	—
RE1	9	24	26	26	AN6	—	—	—	—	—	PSMC3B	—	—	—	—	Y	—
RE2	10	25	27	27	AN7	—	—	—	—	—	PSMC3A	—	—	—	—	Y	—
RE3	1	16	18	18	—	—	—	—	—	—	—	—	—	—	IOC	Y	MCLR VPP
VDD	11, 32	7, 26	7, 28	7,8, 28	—	—	—	—	—	—	—	—	—	—	—	—	VDD
VSS	12, 31	6, 27	6, 29	6, 30	—	—	—	—	—	—	—	—	—	—	—	—	VSS

**Note 1:** Alternate pin function selected with the APFCON1 (Register 13-1) and APFCON2 (Register 13-2) registers.

## Table of Contents

1.0 Device Overview .....	14
2.0 Enhanced Mid-Range CPU .....	25
3.0 Memory Organization .....	27
4.0 Device Configuration .....	57
5.0 Resets .....	63
6.0 Oscillator Module (with Fail-Safe Clock Monitor) .....	71
7.0 Reference Clock Module .....	89
8.0 Interrupts .....	92
9.0 Power-Down Mode (Sleep) .....	107
10.0 Low Dropout (LDO) Voltage Regulator .....	111
11.0 Watchdog Timer (WDT) .....	112
12.0 Data EEPROM and Flash Program Memory Control .....	116
13.0 I/O Ports .....	130
14.0 Interrupt-On-Change .....	161
15.0 Fixed Voltage Reference (FVR) .....	165
16.0 Temperature Indicator Module .....	168
17.0 Analog-to-Digital Converter (ADC) Module .....	170
18.0 Operational Amplifier (OPA) Modules .....	185
19.0 8-Bit Digital-to-Analog Converter (DAC) Module .....	189
20.0 5-bit Digital-to-Analog Converter (DAC2/3/4) Modules .....	193
21.0 Comparator Module .....	197
22.0 Timer0 Module .....	206
23.0 Timer1 Module with Gate Control .....	209
24.0 Timer2 Module .....	220
25.0 Capture/Compare/PWM Modules .....	224
26.0 Programmable Switch Mode Control (PSMC) .....	232
27.0 Master Synchronous Serial Port (MSSP) Module .....	290
28.0 Enhanced Universal Synchronous Asynchronous Receiver Transmitter (EUSART) .....	344
29.0 In-Circuit Serial Programming™ (ICSP™) .....	373
30.0 Instruction Set Summary .....	375
31.0 Electrical Specifications .....	389
32.0 DC and AC Characteristics Graphs and Charts .....	422
33.0 Development Support .....	446
34.0 Packaging Information .....	450
Appendix A: Data Sheet Revision History .....	470
The Microchip Website .....	471
Customer Change Notification Service .....	471
Customer Support .....	471
Product Identification System .....	472

## 1.0 DEVICE OVERVIEW

The PIC16(L)F1788/9 are described within this data sheet. The block diagram of these devices are shown in [Figure 1-1](#). The available peripherals are shown in [Table 1-1](#), and the pin out descriptions are shown in [Tables 1-2](#) and [1-3](#).

**TABLE 1-1: DEVICE PERIPHERAL SUMMARY**

Peripheral	PIC16(L)F1782	PIC16(L)F1783	PIC16(L)F1784	PIC16(L)F1786	PIC16(L)F1787	PIC16(L)F1788	PIC16(L)F1789
Analog-to-Digital Converter (ADC)	•	•	•	•	•	•	•
Fixed Voltage Reference (FVR)	•	•	•	•	•	•	•
Reference Clock Module	•	•	•	•	•	•	•
Temperature Indicator	•	•	•	•	•	•	•
Capture/Compare/PWM (CCP/ECCP) Modules							
	CCP1	•	•	•	•	•	•
	CCP2	•	•	•	•	•	•
	CCP3			•	•	•	•
Comparators							
	C1	•	•	•	•	•	•
	C2	•	•	•	•	•	•
	C3	•	•	•	•	•	•
	C4			•	•	•	•
Digital-to-Analog Converter (DAC)							
	(8-bit DAC) D1	•	•	•	•	•	•
	(5-bit DAC) D2					•	•
	(5-bit DAC) D3					•	•
	(5-bit DAC) D4					•	•
Enhanced Universal Synchronous/Asynchronous Receiver/Transmitter (EUSART)							
	EUSART	•	•	•	•	•	•
Master Synchronous Serial Ports							
	MSSP	•	•	•	•	•	•
Op Amp							
	Op Amp 1	•	•	•	•	•	•
	Op Amp 2	•	•	•	•	•	•
	Op Amp 3			•	•		•
Programmable Switch Mode Controller (PSMC)							
	PSMC1	•	•	•	•	•	•
	PSMC2	•	•	•	•	•	•
	PSMC3			•	•	•	•
	PSMC4					•	•
Timers							
	Timer0	•	•	•	•	•	•
	Timer1	•	•	•	•	•	•
	Timer2	•	•	•	•	•	•

# PIC16(L)F1788/9

**FIGURE 1-1: PIC16(L)F1788/9 BLOCK DIAGRAM**

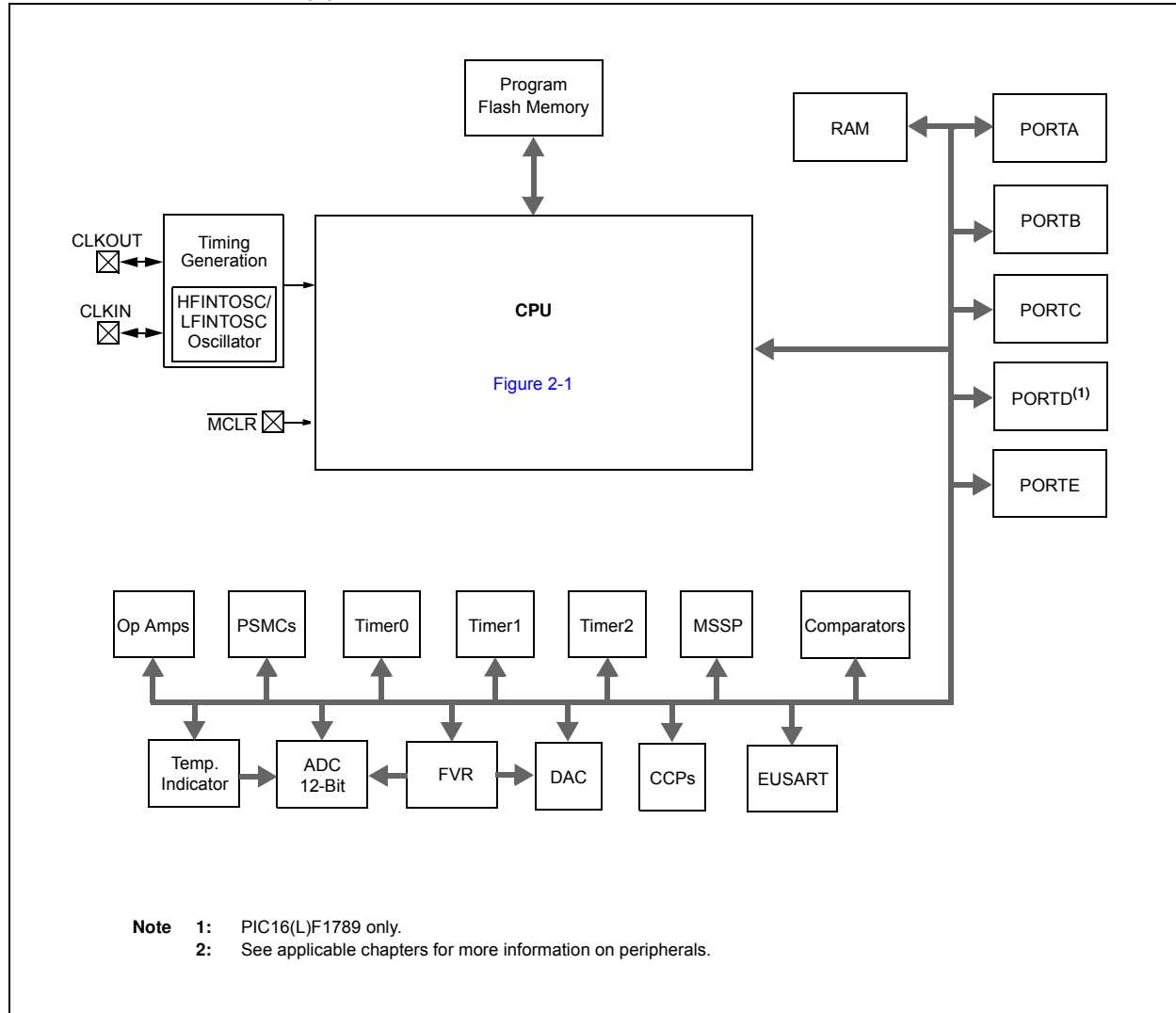



**TABLE 1-2: PIC16(L)F1788 PINOUT DESCRIPTION**

Name	Function	Input Type	Output Type	Description
RA0/AN0/C1IN0-/C2IN0-/C3IN0-/C4IN0-/SS <sup>(1)</sup>	RA0	TTL/ST	CMOS	General purpose I/O.
	AN0	AN	—	ADC Channel 0 input.
	C1IN0-	AN	—	Comparator C1 negative input.
	C2IN0-	AN	—	Comparator C2 negative input.
	C3IN0-	AN	—	Comparator C3 negative input.
	C4IN0-	AN	—	Comparator C4 negative input.
	SS	ST	—	Slave Select input.
RA1/AN1/C1IN1-/C2IN1-/C3IN1-/C4IN1-/OPA1OUT	RA1	TTL/ST	CMOS	General purpose I/O.
	AN1	AN	—	ADC Channel 1 input.
	C1IN1-	AN	—	Comparator C1 negative input.
	C2IN1-	AN	—	Comparator C2 negative input.
	C3IN1-	AN	—	Comparator C3 negative input.
	C4IN1-	AN	—	Comparator C4 negative input.
	OPA1OUT	—	AN	Operational Amplifier 1 output.
RA2/AN2/C1IN0+/C2IN0+/C3IN0+/C4IN0+/DAC1OUT1/VREF-/DAC1VREF-	RA2	TTL/ST	CMOS	General purpose I/O.
	AN2	AN	—	ADC Channel 2 input.
	C1IN0+	AN	—	Comparator C1 positive input.
	C2IN0+	AN	—	Comparator C2 positive input.
	C3IN0+	AN	—	Comparator C3 positive input.
	C4IN0+	AN	—	Comparator C4 positive input.
	DAC1OUT1	—	AN	Digital-to-Analog Converter output.
	VREF-	AN	—	ADC Negative Voltage Reference input.
DAC1VREF-	AN	—	Digital-to-Analog Converter negative reference.	
RA3/AN3/VREF+/C1IN1+/DAC1VREF+/DAC2VREF+/DAC3VREF+/DAC4VREF+	RA3	TTL/ST	CMOS	General purpose I/O.
	AN3	AN	—	ADC Channel 3 input.
	VREF+	AN	—	ADC Voltage Reference input.
	C1IN1+	AN	—	Comparator C1 positive input.
	DAC1VREF+	AN	—	Digital-to-Analog Converter positive reference.
	DAC2VREF+	AN	—	Digital-to-Analog Converter positive reference.
	DAC3VREF+	AN	—	Digital-to-Analog Converter positive reference.
	DAC4VREF+	AN	—	Digital-to-Analog Converter positive reference.
RA4/C1OUT/OPA1IN+/T0CKI/DAC4OUT1	RA4	TTL/ST	CMOS	General purpose I/O.
	C1OUT	—	CMOS	Comparator C1 output.
	OPA1IN+	AN	—	Operational Amplifier 1 non-inverting input.
	T0CKI	ST	—	Timer0 clock input.
	DAC4OUT1	—	AN	Digital-to-Analog Converter output.
RA5/AN4/C2OUT/OPA1IN-/SS <sup>(1)</sup> /DAC2OUT1	RA5	TTL/ST	CMOS	General purpose I/O.
	AN4	AN	—	ADC Channel 4 input.
	C2OUT	—	CMOS	Comparator C2 output.
	OPA1IN-	AN	—	Operational Amplifier 1 inverting input.
	SS	ST	—	Slave Select input.
DAC2OUT1	—	AN	Digital-to-Analog Converter output.	

**Legend:** AN = Analog input or output    CMOS = CMOS compatible input or output    OD = Open-Drain  
TTL = TTL compatible input    ST = Schmitt Trigger input with CMOS levels    I<sup>2</sup>C = Schmitt Trigger input with I<sup>2</sup>C  
HV = High Voltage    XTAL = Crystal levels

**Note 1:** Pin functions can be assigned to one of two locations via software. See [Register 13-1](#).  
**2:** All pins have interrupt-on-change functionality.

# PIC16(L)F1788/9

**TABLE 1-2: PIC16(L)F1788 PINOUT DESCRIPTION (CONTINUED)**

Name	Function	Input Type	Output Type	Description
RA6/C2OUT <sup>(1)</sup> /OSC2/ CLKOUT/VCAP	RA6	TTL/ST	CMOS	General purpose I/O.
	C2OUT	—	CMOS	Comparator C2 output.
	OSC2	—	XTAL	Crystal/Resonator (LP, XT, HS modes).
	CLKOUT	—	CMOS	Fosc/4 output.
	VCAP	Power	Power	Filter capacitor for Voltage Regulator.
RA7/PSMC1CLK/PSMC2CLK/ PSMC3CLK/PSMC4- CLK/OSC1/CLKIN	RA7	TTL/ST	CMOS	General purpose I/O.
	PSMC1CLK	ST	—	PSMC1 clock input.
	PSMC2CLK	ST	—	PSMC2 clock input.
	PSMC3CLK	ST	—	PSMC3 clock input.
	PSMC4CLK	ST	—	PSMC4 clock input.
	OSC1	—	XTAL	Crystal/Resonator (LP, XT, HS modes).
RB0/AN12/C2IN1+/ PSMC1IN/ PSMC2IN/PSMC3IN/PSMC4IN/ CCP1 <sup>(1)</sup> /INT	RB0	TTL/ST	CMOS	General purpose I/O.
	AN12	AN	—	ADC Channel 12 input.
	C2IN1+	AN	—	Comparator C2 positive input.
	PSMC1IN	ST	—	PSMC1 Event Trigger input.
	PSMC2IN	ST	—	PSMC2 Event Trigger input.
	PSMC3IN	ST	—	PSMC3 Event Trigger input.
	PSMC4IN	ST	—	PSMC4 Event Trigger input.
	CCP1	ST	CMOS	Capture/Compare/PWM1.
INT	ST	—	External interrupt.	
RB1/AN10/C1IN3-/C2IN3-/ C3IN3-/C4IN3-/OPA2OUT	RB1	TTL/ST	CMOS	General purpose I/O.
	AN10	AN	—	ADC Channel 10 input.
	C1IN3-	AN	—	Comparator C1 negative input.
	C2IN3-	AN	—	Comparator C2 negative input.
	C3IN3-	AN	—	Comparator C3 negative input.
	C4IN3-	AN	—	Comparator C4 negative input.
	OPA2OUT	—	AN	Operational Amplifier 2 output.
RB2/AN8/OPA2IN-/CLKR/ DAC3OUT1	RB2	TTL/ST	CMOS	General purpose I/O.
	AN8	AN	—	ADC Channel 8 input.
	OPA2IN-	AN	—	Operational Amplifier 2 inverting input.
	CLKR	—	CMOS	Clock output.
	DAC3OUT1	—	AN	Digital-to-Analog Converter output.
RB3/AN9/C1IN2-/C2IN2-/ C3IN2-/OPA2IN+/CCP2 <sup>(1)</sup>	RB3	TTL/ST	CMOS	General purpose I/O.
	AN9	AN	—	ADC Channel 9 input.
	C1IN2-	AN	—	Comparator C1 negative input.
	C2IN2-	AN	—	Comparator C2 negative input.
	C3IN2-	AN	—	Comparator C3 negative input.
	OPA2IN+	AN	—	Operational Amplifier 2 non-inverting input.
	CCP2	ST	CMOS	Capture/Compare/PWM2.

**Legend:** AN = Analog input or output    CMOS = CMOS compatible input or output    OD = Open-Drain  
TTL = TTL compatible input    ST = Schmitt Trigger input with CMOS levels    I<sup>2</sup>C = Schmitt Trigger input with I<sup>2</sup>C  
HV = High Voltage    XTAL = Crystal levels

- Note 1:** Pin functions can be assigned to one of two locations via software. See [Register 13-1](#).  
**Note 2:** All pins have interrupt-on-change functionality.

**TABLE 1-2: PIC16(L)F1788 PINOUT DESCRIPTION (CONTINUED)**

Name	Function	Input Type	Output Type	Description
RB4/AN11/C3IN1+/ $\overline{SS}^{(1)}$	RB4	TTL/ST	CMOS	General purpose I/O.
	AN11	AN	—	ADC Channel 11 input.
	C3IN1+	AN	—	Comparator C3 positive input.
	$\overline{SS}$	ST	—	Slave Select input.
RB5/AN13/C4IN2-/T1G/CCP3 <sup>(1)</sup> SDO <sup>(1)</sup> /C3OUT	RB5	TTL/ST	CMOS	General purpose I/O.
	AN13	AN	—	ADC Channel 13 input.
	C4IN2-	AN	—	Comparator C4 negative input.
	T1G	ST	—	Timer1 gate input.
	CCP3	ST	CMOS	Capture/Compare/PWM3.
	SDO	—	CMOS	SPI data output.
RB6/C4IN1+/TX <sup>(1)</sup> /CK <sup>(1)</sup> /SDI <sup>(1)</sup> / SDA <sup>(1)</sup> /ICSPCLK	RB6	TTL/ST	CMOS	General purpose I/O.
	C4IN1+	AN	—	Comparator C4 positive input.
	TX	—	CMOS	EUSART asynchronous transmit.
	CK	ST	CMOS	EUSART synchronous clock.
	SDI	ST	—	SPI data input.
	SDA	I <sup>2</sup> C	OD	I <sup>2</sup> C data input/output.
RB7/DAC1OUT2/DAC2OUT2/ DAC3OUT2/DAC4OUT2/RX <sup>(1)</sup> / DT <sup>(1)</sup> /SCK <sup>(1)</sup> /SCL <sup>(1)</sup> /ICSPDAT	RB7	TTL/ST	CMOS	General purpose I/O.
	DAC1OUT2	—	AN	Voltage Reference output.
	DAC2OUT2	—	AN	Voltage Reference output.
	DAC3OUT2	—	AN	Voltage Reference output.
	DAC4OUT2	—	AN	Voltage Reference output.
	RX	ST	—	EUSART asynchronous input.
	DT	ST	CMOS	EUSART synchronous data.
	SCK	ST	CMOS	SPI clock.
	SCL	I <sup>2</sup> C	OD	I <sup>2</sup> C clock.
ICSPDAT	ST	CMOS	ICSP™ Data I/O.	
RC0/T1OSO/T1CKI/PSMC1A	RC0	TTL/ST	CMOS	General purpose I/O.
	T1OSO	XTAL	XTAL	Timer1 Oscillator Connection.
	T1CKI	ST	—	Timer1 clock input.
	PSMC1A	—	CMOS	PSMC1 output A.
RC1/T1OSI/PSMC1B/CCP2	RC1	TTL/ST	CMOS	General purpose I/O.
	T1OSI	XTAL	XTAL	Timer1 Oscillator Connection.
	PSMC1B	—	CMOS	PSMC1 output B.
	CCP2	ST	CMOS	Capture/Compare/PWM2.
RC2/PSMC1C/PSMC3B/CCP1	RC2	TTL/ST	CMOS	General purpose I/O.
	PSMC1C	—	CMOS	PSMC1 output C.
	PSMC3B	—	CMOS	PSMC3 output B.
	CCP1	ST	CMOS	Capture/Compare/PWM1.

**Legend:** AN = Analog input or output    CMOS = CMOS compatible input or output    OD = Open-Drain  
TTL = TTL compatible input    ST = Schmitt Trigger input with CMOS levels    I<sup>2</sup>C = Schmitt Trigger input with I<sup>2</sup>C  
HV = High Voltage    XTAL = Crystal levels

- Note 1:** Pin functions can be assigned to one of two locations via software. See [Register 13-1](#).  
**Note 2:** All pins have interrupt-on-change functionality.

# PIC16(L)F1788/9

**TABLE 1-2: PIC16(L)F1788 PINOUT DESCRIPTION (CONTINUED)**

Name	Function	Input Type	Output Type	Description
RC3/PSMC1D/PSMC4A/SCK/SCL	RC3	TTL/ST	CMOS	General purpose I/O.
	PSMC1D	—	CMOS	PSMC1 output D.
	PSMC4A	—	CMOS	PSMC4 output A.
	SCK	ST	CMOS	SPI clock.
	SCL	I <sup>2</sup> C	OD	I <sup>2</sup> C clock.
RC4/PSMC1E/PSMC4B/SDI/SDA	RC4	TTL/ST	CMOS	General purpose I/O.
	PSMC1E	—	CMOS	PSMC1 output E.
	PSMC4B	—	CMOS	PSMC4 output B.
	SDI	ST	—	SPI data input.
	SDA	I <sup>2</sup> C	OD	I <sup>2</sup> C data input/output.
RC5/PSMC1F/PSMC3A/SDO	RC5	TTL/ST	CMOS	General purpose I/O.
	PSMC1F	—	CMOS	PSMC1 output F.
	PSMC3A	—	CMOS	PSMC3 output A.
	SDO	—	CMOS	SPI data output.
RC6/PSMC2A/TX/CK/CCP3	RC6	TTL/ST	CMOS	General purpose I/O.
	PSMC2A	—	CMOS	PSMC2 output A.
	TX	—	CMOS	EUSART asynchronous transmit.
	CK	ST	CMOS	EUSART synchronous clock.
	CCP3	ST	CMOS	Capture/Compare/PWM3.
RC7/C4OUT/PSMC2B/RX/DT	RC7	TTL/ST	CMOS	General purpose I/O.
	C4OUT	—	CMOS	Comparator C4 output.
	PSMC2B	—	CMOS	PSMC2 output B.
	RX	ST	—	EUSART asynchronous input.
	DT	ST	CMOS	EUSART synchronous data.
RE3/ $\overline{\text{MCLR}}$ /VPP	RE3	TTL/ST	—	General purpose input.
	$\overline{\text{MCLR}}$	ST	—	Master Clear with internal pull-up.
	VPP	HV	—	Programming voltage.
VDD	VDD	Power	—	Positive supply.
VSS	VSS	Power	—	Ground reference.

**Legend:** AN = Analog input or output    CMOS = CMOS compatible input or output    OD = Open-Drain  
TTL = TTL compatible input    ST = Schmitt Trigger input with CMOS levels    I<sup>2</sup>C = Schmitt Trigger input with I<sup>2</sup>C  
HV = High Voltage    XTAL = Crystal levels

- Note 1:** Pin functions can be assigned to one of two locations via software. See [Register 13-1](#).  
**Note 2:** All pins have interrupt-on-change functionality.

**TABLE 1-3: PIC16(L)F1789 PINOUT DESCRIPTION**

Name	Function	Input Type	Output Type	Description
RA0/AN0/C1IN0-/C2IN0-/C3IN0-/C4IN0-/SS <sup>(1)</sup>	RA0	TTL/ST	CMOS	General purpose I/O.
	AN0	AN	—	ADC Channel 0 input.
	C1IN0-	AN	—	Comparator C1 negative input.
	C2IN0-	AN	—	Comparator C2 negative input.
	C3IN0-	AN	—	Comparator C3 negative input.
	C4IN0-	AN	—	Comparator C4 negative input.
	SS	ST	—	Slave Select input.
RA1/AN1/C1IN1-/C2IN1-/C3IN1-/C4IN1-/OPA1OUT	RA1	TTL/ST	CMOS	General purpose I/O.
	AN1	AN	—	ADC Channel 1 input.
	C1IN1-	AN	—	Comparator C1 negative input.
	C2IN1-	AN	—	Comparator C2 negative input.
	C3IN1-	AN	—	Comparator C3 negative input.
	C4IN1-	AN	—	Comparator C4 negative input.
	OPA1OUT	—	AN	Operational Amplifier 1 output.
RA2/AN2/C1IN0+/C2IN0+/C3IN0+/C4IN0+/DAC1OUT1/VREF-/DAC1VREF-	RA2	TTL/ST	CMOS	General purpose I/O.
	AN2	AN	—	ADC Channel 2 input.
	C1IN0+	AN	—	Comparator C1 positive input.
	C2IN0+	AN	—	Comparator C2 positive input.
	C3IN0+	AN	—	Comparator C3 positive input.
	C4IN0+	AN	—	Comparator C4 positive input.
	DAC1OUT1	—	AN	Digital-to-Analog Converter output.
	VREF-	AN	—	ADC Negative Voltage Reference input.
DAC1VREF-	AN	—	Digital-to-Analog Converter negative reference.	
RA3/AN3/VREF+/C1IN1+/DAC1VREF+/DAC2VREF+/DAC3VREF+/DAC4VREF+	RA3	TTL/ST	CMOS	General purpose I/O.
	AN3	AN	—	ADC Channel 3 input.
	VREF+	AN	—	ADC Voltage Reference input.
	C1IN1+	AN	—	Comparator C1 positive input.
	DAC1VREF+	AN	—	Digital-to-Analog Converter positive reference.
	DAC2VREF+	AN	—	Digital-to-Analog Converter positive reference.
	DAC3VREF+	AN	—	Digital-to-Analog Converter positive reference.
	DAC4VREF+	AN	—	Digital-to-Analog Converter positive reference.
RA4/C1OUT/OPA1IN+/T0CKI	RA4	TTL/ST	CMOS	General purpose I/O.
	C1OUT	—	CMOS	Comparator C1 output.
	OPA1IN+	AN	—	Operational Amplifier 1 non-inverting input.
	T0CKI	ST	—	Timer0 clock input.
RA5/AN4/C2OUT/OPA1IN-/SS <sup>(1)</sup> /DAC2OUT1	RA5	TTL/ST	CMOS	General purpose I/O.
	AN4	AN	—	ADC Channel 4 input.
	C2OUT	—	CMOS	Comparator C2 output.
	OPA1IN-	AN	—	Operational Amplifier 1 inverting input.
	SS	ST	—	Slave Select input.
DAC2OUT1	—	AN	Digital-to-Analog Converter output.	

**Legend:** AN = Analog input or output    CMOS = CMOS compatible input or output    OD = Open-Drain  
TTL = TTL compatible input    ST = Schmitt Trigger input with CMOS levels    I<sup>2</sup>C = Schmitt Trigger input with I<sup>2</sup>C levels  
HV = High Voltage    XTAL = Crystal

**Note 1:** Pin functions can be assigned to one of two locations via software. See [Register 13-1](#).  
**2:** All pins have interrupt-on-change functionality.

# PIC16(L)F1788/9

**TABLE 1-3: PIC16(L)F1789 PINOUT DESCRIPTION (CONTINUED)**

Name	Function	Input Type	Output Type	Description
RA6/C2OUT <sup>(1)</sup> /OSC2/ CLKOUT/VCAP	RA6	TTL/ST	CMOS	General purpose I/O.
	C2OUT	—	CMOS	Comparator C2 output.
	OSC2	—	XTAL	Crystal/Resonator (LP, XT, HS modes).
	CLKOUT	—	CMOS	Fosc/4 output.
	VCAP	Power	Power	Filter capacitor for Voltage Regulator.
RA7/PSMC1CLK/PSMC2CLK/ PSMC3CLK/PSMC4- CLK/OSC1/CLKIN	RA7	TTL/ST	CMOS	General purpose I/O.
	PSMC1CLK	ST	—	PSMC1 clock input.
	PSMC2CLK	ST	—	PSMC2 clock input.
	PSMC3CLK	ST	—	PSMC3 clock input.
	PSMC4CLK	ST	—	PSMC4 clock input.
	OSC1	—	XTAL	Crystal/Resonator (LP, XT, HS modes).
RB0/AN12/C2IN1+/PSMC1IN/ PSMC2IN/PSMC3IN/PSMC4IN/ CCP1 <sup>(1)</sup> /INT	RB0	TTL/ST	CMOS	General purpose I/O.
	AN12	AN	—	ADC Channel 12 input.
	C2IN1+	AN	—	Comparator C2 positive input.
	PSMC1IN	ST	—	PSMC1 Event Trigger input.
	PSMC2IN	ST	—	PSMC2 Event Trigger input.
	PSMC3IN	ST	—	PSMC3 Event Trigger input.
	PSMC4IN	ST	—	PSMC4 Event Trigger input.
	CCP1	ST	CMOS	Capture/Compare/PWM1.
INT	ST	—	External interrupt.	
RB1/AN10/C1IN3-/C2IN3-/ C3IN3-/C4IN3-/OPA2OUT	RB1	TTL/ST	CMOS	General purpose I/O.
	AN10	AN	—	ADC Channel 10 input.
	C1IN3-	AN	—	Comparator C1 negative input.
	C2IN3-	AN	—	Comparator C2 negative input.
	C3IN3-	AN	—	Comparator C3 negative input.
	C4IN3-	AN	—	Comparator C4 negative input.
	OPA2OUT	—	AN	Operational Amplifier 2 output.
RB2/AN8/OPA2IN-/CLKR/ DAC3OUT1	RB2	TTL/ST	CMOS	General purpose I/O.
	AN8	AN	—	ADC Channel 8 input.
	OPA2IN-	AN	—	Operational Amplifier 2 inverting input.
	CLKR	—	CMOS	Clock output.
RB3/AN9/C1IN2-/C2IN2-/ C3IN2-/OPA2IN+/CCP2 <sup>(1)</sup>	RB3	TTL/ST	CMOS	General purpose I/O.
	AN9	AN	—	ADC Channel 9 input.
	C1IN2-	AN	—	Comparator C1 negative input.
	C2IN2-	AN	—	Comparator C2 negative input.
	C3IN2-	AN	—	Comparator C3 negative input.
	OPA2IN+	AN	—	Operational Amplifier 2 non-inverting input.
	CCP2	ST	CMOS	Capture/Compare/PWM2.

**Legend:** AN = Analog input or output    CMOS = CMOS compatible input or output    OD = Open-Drain  
TTL = TTL compatible input    ST = Schmitt Trigger input with CMOS levels    I<sup>2</sup>C = Schmitt Trigger input with I<sup>2</sup>C levels  
HV = High Voltage    XTAL = Crystal

- Note 1:** Pin functions can be assigned to one of two locations via software. See [Register 13-1](#).  
**Note 2:** All pins have interrupt-on-change functionality.

**TABLE 1-3: PIC16(L)F1789 PINOUT DESCRIPTION (CONTINUED)**

Name	Function	Input Type	Output Type	Description	
RB4/AN11/C3IN1+/ $\overline{SS}^{(1)}$	RB4	TTL/ST	CMOS	General purpose I/O.	
	AN11	AN	—	ADC Channel 11 input.	
	C3IN1+	AN	—	Comparator C3 positive input.	
	$\overline{SS}$	ST	—	Slave Select input.	
RB5/AN13/C4IN2-/T1G/CCP3 <sup>(1)</sup> SDO <sup>(1)</sup>	RB5	TTL/ST	CMOS	General purpose I/O.	
	AN13	AN	—	ADC Channel 13 input.	
	C4IN2-	AN	—	Comparator C4 negative input.	
	T1G	ST	—	Timer1 gate input.	
	CCP3	ST	CMOS	Capture/Compare/PWM3.	
RB6/C4IN1+/TX <sup>(1)</sup> /CK <sup>(1)</sup> /SDI <sup>(1)</sup> / SDA <sup>(1)</sup> /ICSPCLK	RB6	TTL/ST	CMOS	General purpose I/O.	
	C4IN1+	AN	—	Comparator C4 positive input.	
	TX	—	CMOS	EUSART asynchronous transmit.	
	CK	ST	CMOS	EUSART synchronous clock.	
	SDI	ST	—	SPI data input.	
	SDA	I <sup>2</sup> C	OD	I <sup>2</sup> C data input/output.	
	ICSPCLK	ST	—	Serial Programming Clock.	
RB7/DAC1OUT2/DAC2OUT2/ DAC3OUT2/DAC4OUT2/RX <sup>(1)</sup> / DT <sup>(1)</sup> /SCK <sup>(1)</sup> /SCL <sup>(1)</sup> /ICSPDAT	RB7	TTL/ST	CMOS	General purpose I/O.	
	DAC1OUT2	—	AN	Voltage Reference output.	
	DAC2OUT2	—	AN	Voltage Reference output.	
	DAC3OUT2	—	AN	Voltage Reference output.	
	DAC4OUT2	—	AN	Voltage Reference output.	
	RX	ST	—	EUSART asynchronous input.	
	DT	ST	CMOS	EUSART synchronous data.	
	SCK	ST	CMOS	SPI clock.	
	SCL	I <sup>2</sup> C	OD	I <sup>2</sup> C clock.	
RC0/T1OSO/T1CKI/PSMC1A	RC0	TTL/ST	CMOS	General purpose I/O.	
	T1OSO	XTAL	XTAL	Timer1 Oscillator Connection.	
	T1CKI	ST	—	Timer1 clock input.	
	PSMC1A	—	CMOS	PSMC1 output A.	
	RC1/T1OSI/PSMC1B/CCP2	RC1	TTL/ST	CMOS	General purpose I/O.
		T1OSI	XTAL	XTAL	Timer1 Oscillator Connection.
		PSMC1B	—	CMOS	PSMC1 output B.
		CCP2	ST	CMOS	Capture/Compare/PWM2.
RC2/PSMC1C/CCP1	RC2	TTL/ST	CMOS	General purpose I/O.	
	PSMC1C	—	CMOS	PSMC1 output C.	
	CCP1	ST	CMOS	Capture/Compare/PWM1.	
RC3/PSMC1D/SCK/SCL	RC3	TTL/ST	CMOS	General purpose I/O.	
	PSMC1D	—	CMOS	PSMC1 output D.	
	SCK	ST	CMOS	SPI clock.	
	SCL	I <sup>2</sup> C	OD	I <sup>2</sup> C clock.	

**Legend:** AN = Analog input or output    CMOS = CMOS compatible input or output    OD = Open-Drain  
TTL = TTL compatible input    ST = Schmitt Trigger input with CMOS levels    I<sup>2</sup>C = Schmitt Trigger input with I<sup>2</sup>C levels  
HV = High Voltage    XTAL = Crystal

- Note** 1: Pin functions can be assigned to one of two locations via software. See [Register 13-1](#).  
2: All pins have interrupt-on-change functionality.

# PIC16(L)F1788/9

**TABLE 1-3: PIC16(L)F1789 PINOUT DESCRIPTION (CONTINUED)**

Name	Function	Input Type	Output Type	Description
RC4/PSMC1E/SDI/SDA	RC4	TTL/ST	CMOS	General purpose I/O.
	PSMC1E	—	CMOS	PSMC1 output E.
	SDI	ST	—	SPI data input.
	SDA	I <sup>2</sup> C	OD	I <sup>2</sup> C data input/output.
RC5/PSMC1F/SDO	RC5	TTL/ST	CMOS	General purpose I/O.
	PSMC1F	—	CMOS	PSMC1 output F.
	SDO	—	CMOS	SPI data output.
RC6/PSMC2A/TX/CK	RC6	TTL/ST	CMOS	General purpose I/O.
	PSMC2A	—	CMOS	PSMC2 output A.
	TX	—	CMOS	EUSART asynchronous transmit.
	CK	ST	CMOS	EUSART synchronous clock.
RC7/PSMC2B/RX/DT	RC7	TTL/ST	CMOS	General purpose I/O.
	PSMC2B	—	CMOS	PSMC2 output B.
	RX	ST	—	EUSART asynchronous input.
	DT	ST	CMOS	EUSART synchronous data.
RD0/OPA3IN+	RD0	TTL/ST	CMOS	General purpose I/O.
	OPA3IN+	AN	—	Operational Amplifier 3 non-inverting input.
RD1/AN21/C1IN4-/C2IN4-/C3IN4-/C4IN4-/OPA3OUT	RD1	TTL/ST	CMOS	General purpose I/O.
	AN21	AN	—	ADC Channel 21 input.
	C1IN4-	AN	—	Comparator C4 negative input.
	C2IN4-	AN	—	Comparator C4 negative input.
	C3IN4-	AN	—	Comparator C4 negative input.
	C4IN4-	AN	—	Comparator C4 negative input.
	OPA3OUT	—	AN	Operational Amplifier 3 output.
RD2/OPA3IN-/DAC4OUT1	RD2	TTL/ST	CMOS	General purpose I/O.
	OPA3IN-	AN	—	Operational Amplifier 3 inverting input.
	DAC4OUT1	—	AN	Digital-to-Analog Converter output.
RD3/PSMC4A	RD3	TTL/ST	CMOS	General purpose I/O.
	PSMC4A	—	CMOS	PSMC4 output A.
RD4/PSMC3F	RD4	TTL/ST	CMOS	General purpose I/O.
	PSMC3F	—	CMOS	PSMC3 output F.
RD5/PSMC3E	RD5	TTL/ST	CMOS	General purpose I/O.
	PSMC3E	—	CMOS	PSMC3 output E.
RD6/C3OUT/PSMC3D	RD6	TTL/ST	CMOS	General purpose I/O.
	C3OUT	—	CMOS	Comparator C3 output.
	PSMC3D	—	CMOS	PSMC3 output D.
RD7/C4OUT/PSMC3C	RD7	TTL/ST	CMOS	General purpose I/O.
	C4OUT	—	CMOS	Comparator C4 output.
	PSMC3C	—	CMOS	PSMC3 output C.
RE0/AN5/CCP3/PSMC4B	RE0	TTL/ST	—	General purpose input.
	AN5	AN	—	ADC Channel 5 input.
	CCP3	ST	CMOS	Capture/Compare/PWM3.
	PSMC4B	—	CMOS	PSMC4 output B.

**Legend:** AN = Analog input or output    CMOS = CMOS compatible input or output    OD = Open-Drain  
TTL = TTL compatible input    ST = Schmitt Trigger input with CMOS levels    I<sup>2</sup>C = Schmitt Trigger input with I<sup>2</sup>C levels  
HV = High Voltage    XTAL = Crystal

**Note 1:** Pin functions can be assigned to one of two locations via software. See [Register 13-1](#).  
**2:** All pins have interrupt-on-change functionality.



**TABLE 1-3: PIC16(L)F1789 PINOUT DESCRIPTION (CONTINUED)**

Name	Function	Input Type	Output Type	Description
RE1/AN6/PSMC3B	RE1	TTL/ST	CMOS	General purpose I/O.
	AN6	AN	—	ADC Channel 6 input.
	PSMC3B	—	CMOS	PSMC3 output B.
RE2/AN7/PSMC3A	RE2	TTL/ST	CMOS	General purpose I/O.
	AN7	AN	—	ADC Channel 7 input.
	PSMC3A	—	CMOS	PSMC3 output A.
RE3/MCLR/VPP	RE3	TTL/ST	—	General purpose input.
	MCLR	ST	—	Master Clear with internal pull-up.
	VPP	HV	—	Programming voltage.
VDD	VDD	Power	—	Positive supply.
VSS	VSS	Power	—	Ground reference.

**Legend:** AN = Analog input or output    CMOS = CMOS compatible input or output    OD = Open-Drain  
TTL = TTL compatible input    ST = Schmitt Trigger input with CMOS levels    I<sup>2</sup>C = Schmitt Trigger input with I<sup>2</sup>C levels  
HV = High Voltage    XTAL = Crystal

**Note 1:** Pin functions can be assigned to one of two locations via software. See [Register 13-1](#).

**2:** All pins have interrupt-on-change functionality.

## 2.0 ENHANCED MID-RANGE CPU

This family of devices contain an enhanced mid-range 8-bit CPU core. The CPU has 49 instructions. Interrupt capability includes automatic context saving. The hardware stack is 16 levels deep and has Overflow and Underflow Reset capability. Direct, Indirect, and

Relative addressing modes are available. Two File Select Registers (FSRs) provide the ability to read program and data memory.

- Automatic Interrupt Context Saving
- 16-level Stack with Overflow and Underflow
- File Select Registers
- Instruction Set

**FIGURE 2-1: CORE BLOCK DIAGRAM**

