



Chipsmall Limited consists of a professional team with an average of over 10 year of expertise in the distribution of electronic components. Based in Hongkong, we have already established firm and mutual-benefit business relationships with customers from,Europe,America and south Asia,supplying obsolete and hard-to-find components to meet their specific needs.

With the principle of "Quality Parts,Customers Priority,Honest Operation,and Considerate Service",our business mainly focus on the distribution of electronic components. Line cards we deal with include Microchip,ALPS,ROHM,Xilinx,Pulse,ON,Everlight and Freescale. Main products comprise IC,Modules,Potentiometer,IC Socket,Relay,Connector.Our parts cover such applications as commercial,industrial, and automotives areas.

We are looking forward to setting up business relationship with you and hope to provide you with the best service and solution. Let us make a better world for our industry!



Contact us

Tel: +86-755-8981 8866 Fax: +86-755-8427 6832

Email & Skype: info@chipsmall.com Web: www.chipsmall.com

Address: A1208, Overseas Decoration Building, #122 Zhenhua RD., Futian, Shenzhen, China



28/40/44-Pin, Low-Power, High-Performance Microcontrollers with XLP Technology

Description

PIC18(L)F27/47K40 microcontrollers feature Analog, Core Independent Peripherals and Communication Peripherals, combined with eXtreme Low-Power (XLP) technology for a wide range of general purpose and low-power applications. These 28/40/44-pin devices are equipped with a 10-bit ADC with Computation (ADCC) automating Capacitive Voltage Divider (CVD) techniques for advanced touch sensing, averaging, filtering, oversampling and performing automatic threshold comparisons. They also offer a set of Core Independent Peripherals such as Complementary Waveform Generator (CWG), Windowed Watchdog Timer (WWDT), Cyclic Redundancy Check (CRC)/Memory Scan, Zero-Cross Detect (ZCD) and Peripheral Pin Select (PPS), providing for increased design flexibility and lower system cost.

Core Features

- C Compiler Optimized RISC Architecture
- Operating Speed:
 - DC – 64 MHz clock input
 - 62.5 ns minimum instruction cycle
- Programmable 2-Level Interrupt Priority
- 31-Level Deep Hardware Stack
- Three 8-Bit Timers (TMR2/4/6) with Hardware Limit Timer (HLT)
- Four 16-Bit Timers (TMR0/1/3/5)
- Low-Current Power-on Reset (POR)
- Power-up Timer (PWRT)
- Brown-out Reset (BOR)
- Low-Power BOR (LPBOR) Option
- Programmable Code Protection
- Windowed Watchdog Timer (WWDT):
 - Timer monitoring of overflow and underflow events
 - Variable prescaler selection
 - Variable window size selection
 - All sources configurable in hardware or software

Memory

- 128K bytes Program Flash Memory
- 3728 Bytes Data SRAM Memory
- 1024 Bytes Data EEPROM
- Direct, Indirect and Relative Addressing modes

Operating Characteristics

- Operating Voltage Ranges:
 - 1.8V to 3.6V (PIC18LF2x/4xK40)
 - 2.3V to 5.5V (PIC18F2x/4xK40)
- Temperature Range:
 - Industrial: -40°C to 85°C
 - Extended: -40°C to 125°C

Power-Saving Operation Modes

- Doze: CPU and Peripherals Running at Different Cycle Rates (typically CPU is lower)
- Idle: CPU Halted While Peripherals Operate
- Sleep: Lowest Power Consumption
- Peripheral Module Disable (PMD):
 - Ability to selectively disable hardware module to minimize active power consumption of unused peripherals

eXtreme Low-Power (XLP) Features

- Sleep mode: 50 nA @ 1.8V, typical
- Windowed Watchdog Timer: 500 nA @ 1.8V, typical
- Secondary Oscillator: 500 nA @ 32 kHz
- Operating Current:
 - 8 uA @ 32 kHz, 1.8V, typical
 - 32 uA/MHz @ 1.8V, typical

Digital Peripherals

- Complementary Waveform Generator (CWG):
 - Rising and falling edge dead-band control
 - Full-bridge, half-bridge, 1-channel drive
 - Multiple signal sources
- Capture/Compare/PWM (CCP) modules:
 - Two CCPs
 - 16-bit resolution for Capture/Compare modes
 - 10-bit resolution for PWM mode
- 10-Bit Pulse-Width Modulators (PWM):
 - Two 10-bit PWMs
- Serial Communications:
 - Two Enhanced USART (EUSART) with Auto-Baud Detect, Auto-wake-up on Start. RS-232, RS-485, LIN compatible
 - SPI
 - I²C, SMBus and PMBus™ compatible
- Up to 35 I/O Pins and One Input Pin:
 - Individually programmable pull-ups
 - Slew rate control
 - Interrupt-on-change on all pins
 - Input level selection control

Digital Peripherals (Continued)

- Programmable CRC with Memory Scan:
 - Reliable data/program memory monitoring for Fail-Safe operation (e.g., Class B)
 - Calculate CRC over any portion of Flash or EEPROM
 - High-speed or background operation
- Hardware Limit Timer (TMR2/4/6+HLT):
 - Hardware monitoring and Fault detection
- Peripheral Pin Select (PPS):
 - Enables pin mapping of digital I/O
- Data Signal Modulator (DSM)

Analog Peripherals

- 10-Bit Analog-to-Digital Converter with Computation (ADC²):
 - 35 external channels
 - Conversion available during Sleep
 - Four internal analog channels
 - Internal and external trigger options
 - Automated math functions on input signals:
 - averaging, filter calculations, oversampling and threshold comparison
- Hardware Capacitive Voltage Divider (CVD) Support:
 - 8-bit precharge timer
 - Adjustable sample and hold capacitor array
 - Guard ring digital output drive
- Zero-Cross Detect (ZCD):
 - Detect when AC signal on pin crosses ground
- 5-Bit Digital-to-Analog Converter (DAC):
 - Output available externally
 - Programmable 5-bit voltage (% of V_{DD})
 - Internal connections to comparators, Fixed Voltage Reference and ADC
- Two Comparators (CMP):
 - Four external inputs
 - External output via PPS
- Fixed Voltage Reference (FVR) module:
 - 1.024V, 2.048V and 4.096V output levels

Clocking Structure

- High-Precision Internal Oscillator Block (HFINTOSC):
 - Selectable frequency range up to 64 MHz
 - ±1% at calibration
- 32 kHz Low-Power Internal Oscillator (LFINTOSC)
- External 32 kHz Crystal Oscillator (SOSC)
- External Oscillator Block:
 - Three crystal/resonator modes
 - 4x PLL with external sources
- Fail-Safe Clock Monitor:
 - Allows for safe shutdown if peripheral clock stops
- Oscillator Start-up Timer (OST)

Programming/Debug Features

- In-Circuit Debug Integrated On-Chip
- In-Circuit Serial Programming™ (ICSP™) via Two Pins
- In-Circuit Debug (ICD) with Three Breakpoints via Two Pins

PIC18(L)F27/47K40

PIC18(L)F2x/4xK40 Family Types

Device	Data Sheet Index	Program Memory Flash (bytes)	Data SRAM (bytes)	Data EEPROM (bytes)	I/O Pins	16-bit Timers	Comparators	10-bit ADC ² with Computation (ch)	5-bit DAC	Zero-Cross Detect	CCP/10-bit PWM	CWG	8-bit TMR with HLT	Windowed Watchdog Timer	CRC with Memory Scan	EUSART	I ² C/SPI	PPS	Peripheral Module Disable	Temperature Indicator	Debug ⁽¹⁾
PIC18(L)F24K40	(1)	16k	1024	256	25	4	2	24	1	1	2/2	1	3	Y	Y	1	1	Y	Y	Y	I
PIC18(L)F25K40	(1)	32k	2048	256	25	4	2	24	1	1	2/2	1	3	Y	Y	1	1	Y	Y	Y	I
PIC18(L)F26K40	(2)	64k	3728	1024	25	4	2	24	1	1	2/2	1	3	Y	Y	2	2	Y	Y	Y	I
PIC18(L)F27K40	(3)	128k	3728	1024	25	4	2	24	1	1	2/2	1	3	Y	Y	2	2	Y	Y	Y	I
PIC18(L)F45K40	(2)	32k	2048	256	36	4	2	35	1	1	2/2	1	3	Y	Y	2	2	Y	Y	Y	I
PIC18(L)F46K40	(2)	64k	3728	1024	36	4	2	35	1	1	2/2	1	3	Y	Y	2	2	Y	Y	Y	I
PIC18(L)F47K40	(3)	128k	3728	1024	36	4	2	35	1	1	2/2	1	3	Y	Y	2	2	Y	Y	Y	I

Note 1: Debugging Methods: (I) – Integrated on Chip.

Data Sheet Index: (Unshaded devices are described in this document.)

1. DS40001843 [PIC18\(L\)F24/25K40 Data Sheet, 28-Pin, 8-bit Flash Microcontrollers](#)
2. DS40001816 [PIC18\(L\)F26/45/46K40 Data Sheet, 28/40/44-Pin, 8-bit Flash Microcontrollers](#)
3. DS40001844 [PIC18\(L\)F27/47K40 Data Sheet, 28/40/44-Pin, 8-bit Flash Microcontrollers](#)

Note: For other small form-factor package availability and marking information, please visit <http://www.microchip.com/packaging> or contact your local sales office.

PIC18(L)F27/47K40

Pin Diagrams

28-pin SPDIP, SOIC, SSOP

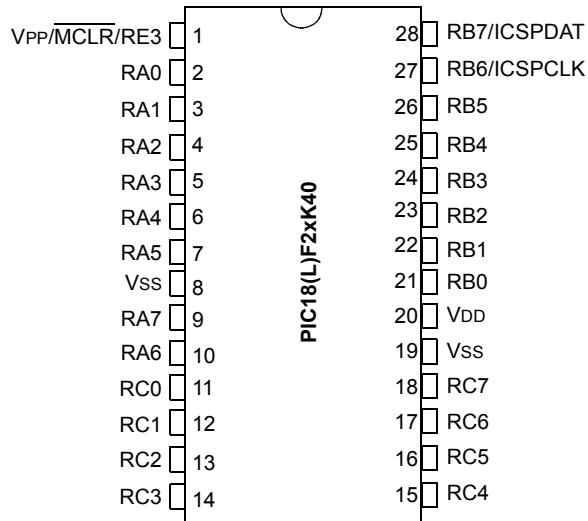

Note: See [Table 1](#) for location of all peripheral functions.

40-pin PDIP

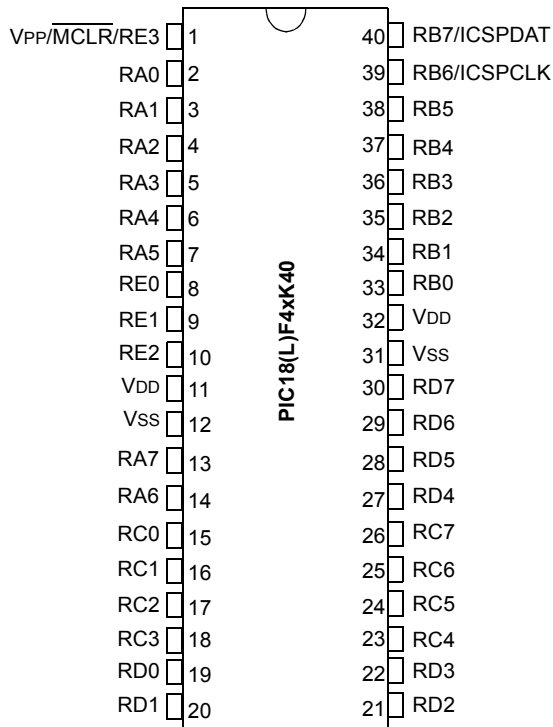

Note: See [Table 2](#) for location of all peripheral functions.

PIC18(L)F27/47K40

40-pin UQFN (5x5x0.5mm)

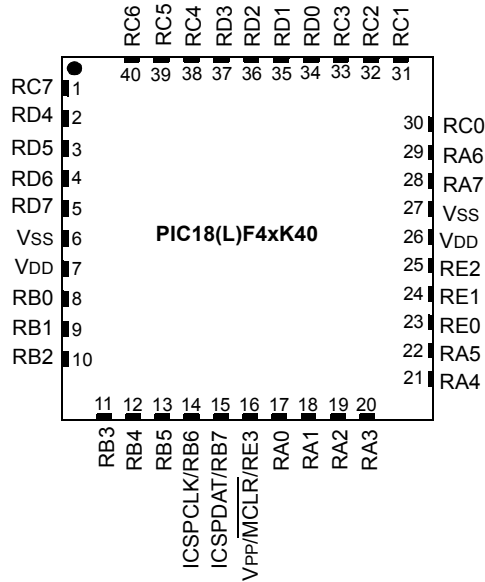

Note 1: See [Table 2](#) for location of all peripheral functions.

- 2: It is recommended that the exposed bottom pad be connected to Vss, however it must not be the only Vss connection to the device.

44-pin QFN (8x8x0.9mm)

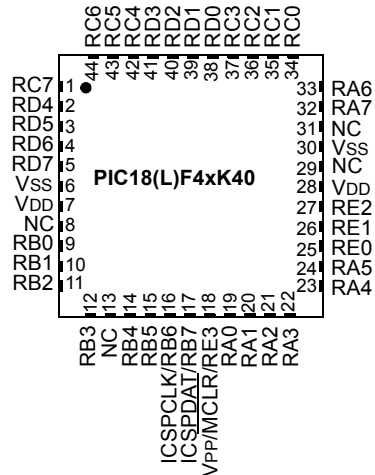

Note 1: See [Table 2](#) for location of all peripheral functions.

- 2: It is recommended that the exposed bottom pad be connected to Vss, however it must not be the only Vss connection to the device.

PIC18(L)F27/47K40

44-pin TQFP

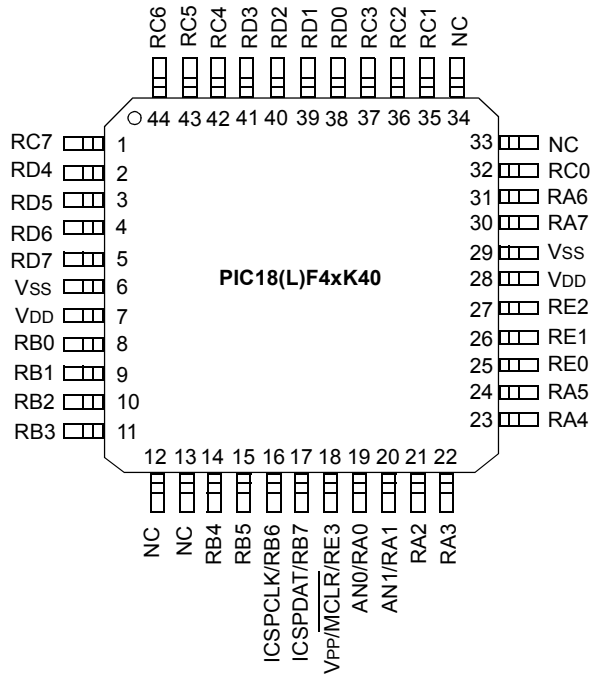

Note: See [Table 2](#) for location of all peripheral functions.

Pin Allocation Tables

TABLE 1: 28-PIN ALLOCATION TABLE (PIC18(L)F27K40)

I/O ⁽²⁾	28-Pin SPDIP, SOIC, SSOP	28-Pin QFN	A/D	Reference	Comparator	Timers	CCP	CWG	ZCD	Interrupt	EUSART	DSM	MSSP	Pull-up	Basic
RA0	2	27	ANA0	—	C1IN0- C2IN0-	—	—	—	—	IOCA0	—	—	—	Y	—
RA1	3	28	ANA1	—	C1IN1- C2IN1-	—	—	—	—	IOCA1	—	—	—	Y	—
RA2	4	1	ANA2	DAC1OUT1 VREF- (DAC) VREF- (ADC)	C1IN0+ C2IN0+	—	—	—	—	IOCA2	—	—	—	Y	—
RA3	5	2	ANA3	VREF+ (DAC) VREF+ (ADC)	C1IN1+	—	—	—	—	IOCA3	—	MDCIN1 ⁽¹⁾	—	Y	—
RA4	6	3	ANA4	—	—	T0CKI ⁽¹⁾	—	—	—	IOCA4	—	MDCIN2 ⁽¹⁾	—	Y	—
RA5	7	4	ANA5	—	—	—	—	—	—	IOCA5	—	MDMIN ⁽¹⁾	SS1 ⁽¹⁾	Y	—
RA6	10	7	ANA6	—	—	—	—	—	—	IOCA6	—	—	—	Y	CLKOUT OSC2
RA7	9	6	ANA7	—	—	—	—	—	—	IOCA7	—	—	—	Y	OSC1 CLKIN
RB0	21	18	ANB0	—	C2IN1+	—	—	CWG1 ⁽¹⁾	ZCDIN	IOCB0 INT0 ⁽¹⁾	—	—	SS2 ⁽¹⁾	Y	—
RB1	22	19	ANB1	—	C1IN3- C2IN3-	—	—	—	—	IOCB1 INT1 ⁽¹⁾	—	—	SCK2 ⁽¹⁾ SCL2 ^(3,4)	Y	—
RB2	23	20	ANB2	—	—	—	—	—	—	IOCB2 INT2 ⁽¹⁾	—	—	SDI2 ⁽¹⁾ SDA2 ^(3,4)	Y	—
RB3	24	21	ANB3	—	C1IN2- C2IN2-	—	—	—	—	IOCB3	—	—	—	Y	—
RB4	25	22	ANB4	—	—	T5G ⁽¹⁾	—	—	—	IOCB4	—	—	—	Y	—
RB5	26	23	ANB5	—	—	T1G ⁽¹⁾	—	—	—	IOCB5	—	—	—	Y	—
RB6	27	24	ANB6	—	—	—	—	—	—	IOCB6	CK2 ⁽¹⁾	—	—	Y	ICSPCLK
RB7	28	25	ANB7	DAC1OUT2	—	T6AIN ⁽¹⁾	—	—	—	IOCB7	RX2/DT2 ⁽¹⁾	—	—	Y	ICSPDAT

- Note**
- 1: Default peripheral input. Input can be moved to any other pin with the PPS input selection registers ([Register 17-1](#)).
 - 2: All pin outputs default to PORT latch data. Any pin can be selected as a peripheral digital output with the PPS output selection registers.
 - 3: These peripheral functions are bidirectional. The output pin selections must be the same as the input pin selections.
 - 4: These pins are configured for I²C logic levels; The SCLx/SDAx signals may be assigned to any of these pins. PPS assignments to the other pins (e.g., RB1) will operate, but input logic levels will be standard TTL/ST as selected by the INLVL register, instead of the I²C specific or SMBus input buffer thresholds.

TABLE 1: 28-PIN ALLOCATION TABLE (PIC18(L)F27K40) (CONTINUED)

I/O ⁽²⁾	28-Pin SPDIP, SOIC, SSOP	28-Pin QFN	A/D	Reference	Comparator	Timers	CCP	CWG	ZCD	Interrupt	EUSART	DSM	MSSP	Pull-up	Basic
RC0	11	8	ANC0	—	—	T1CKI ⁽¹⁾ T3CKI ⁽¹⁾ T3G ⁽¹⁾	—	—	—	IOCC0	—	—	—	Y	SOSCO
RC1	12	9	ANC1	—	—	—	CCP2 ⁽¹⁾	—	—	IOCC1	—	—	—	Y	SOSCIN SOSCI
RC2	13	10	ANC2	—	—	T5CKI ⁽¹⁾	CCP1 ⁽¹⁾	—	—	IOCC2	—	—	—	Y	—
RC3	14	11	ANC3	—	—	T2AIN ⁽¹⁾	—	—	—	IOCC3	—	—	SCK1 ⁽¹⁾ SCL1 ^(3,4)	Y	—
RC4	15	12	ANC4	—	—	—	—	—	—	IOCC4	—	—	SDI1 ⁽¹⁾ SDA1 ^(3,4)	Y	—
RC5	16	13	ANC5	—	—	T4AIN ⁽¹⁾	—	—	—	IOCC5	—	—	—	Y	—
RC6	17	14	ANC6	—	—	—	—	—	—	IOCC6	CK1 ⁽¹⁾	—	—	Y	—
RC7	18	15	ANC7	—	—	—	—	—	—	IOCC7	RX1/DT1 ⁽¹⁾	—	—	Y	—
RE3	1	26	—	—	—	—	—	—	—	IOCE3	—	—	—	Y	VPP/MCLR
Vss	19	16	—	—	—	—	—	—	—	—	—	—	—	—	Vss
VDD	20	17	—	—	—	—	—	—	—	—	—	—	—	—	VDD
Vss	8	5	—	—	—	—	—	—	—	—	—	—	—	—	Vss
OUT ⁽²⁾	—	—	ADGRDA ADGRDB	—	C1OUT C2OUT	TMR0	CCP1 CCP2 PWM3 PWM4	CWG1A CWG1B CWG1C CWG1D	—	—	TX1/CK1 ⁽³⁾ DT1 ⁽³⁾ TX2/CK2 ⁽³⁾ DT2 ⁽³⁾	DSM	SDO1 SCK1 SDO2 SCK2	—	—

- Note**
- 1: Default peripheral input. Input can be moved to any other pin with the PPS input selection registers ([Register 17-1](#)).
 - 2: All pin outputs default to PORT latch data. Any pin can be selected as a peripheral digital output with the PPS output selection registers.
 - 3: These peripheral functions are bidirectional. The output pin selections must be the same as the input pin selections.
 - 4: These pins are configured for I²C logic levels; The SCLx/SDAx signals may be assigned to any of these pins. PPS assignments to the other pins (e.g., RB1) will operate, but input logic levels will be standard TTL/ST as selected by the INLVL register, instead of the I²C specific or SMBus input buffer thresholds.

TABLE 2: 40/44-PIN ALLOCATION TABLE (PIC18(L)F47K40)

I/O ⁽²⁾	40-Pin PDIP	40-Pin UQFN	44-Pin QFN	44-Pin TQFP	A/D	Reference	Comparator	Timers	CCP	CWG	ZCD	Interrupt	EUSART	DSM	MSSP	Pull-up	Basic
RA0	2	17	19	19	ANA0	—	C1IN0- C2IN0-	—	—	—	—	IOCA0	—	—	—	Y	—
RA1	3	18	20	20	ANA1	—	C1IN1- C2IN1-	—	—	—	—	IOCA1	—	—	—	Y	—
RA2	4	19	21	21	ANA2	DAC1OUT1 VREF- (DAC5) VREF- (ADC)	C1IN0+ C2IN0+	—	—	—	—	IOCA2	—	—	—	Y	—
RA3	5	20	22	22	ANA3	VREF+ (DAC5) VREF+ (ADC)	C1IN1+	—	—	—	—	IOCA3	—	MDCIN1 ⁽¹⁾	—	Y	—
RA4	6	21	23	23	ANA4	—	—	T0CKI ⁽¹⁾	—	—	—	IOCA4	—	MDCIN2 ⁽¹⁾	—	Y	—
RA5	7	22	24	24	ANA5	—	—	—	—	—	—	IOCA5	—	MDMIN ⁽¹⁾	SS1 ⁽¹⁾	Y	—
RA6	14	29	33	31	ANA6	—	—	—	—	—	—	IOCA6	—	—	—	Y	CLKOUT OSC2
RA7	13	28	32	30	ANA7	—	—	—	—	—	—	IOCA7	—	—	—	Y	OSC1 CLKIN
RB0	33	8	9	8	ANB0	—	C2IN1+	—	—	CWG1 ⁽¹⁾	ZCDIN	IOCB0 INT0 ⁽¹⁾	—	—	SS2 ⁽¹⁾	Y	—
RB1	34	9	10	9	ANB1	—	C1IN3- C2IN3-	—	—	—	—	IOCB1 INT1 ⁽¹⁾	—	—	SCK2 ⁽¹⁾ SCL2 ^(3,4)	Y	—
RB2	35	10	11	10	ANB2	—	—	—	—	—	—	IOCB2 INT2 ⁽¹⁾	—	—	SDI2 ⁽¹⁾ SDA2 ^(3,4)	Y	—
RB3	36	11	12	11	ANB3	—	C1IN2- C2IN2-	—	—	—	—	IOCB3	—	—	—	Y	—
RB4	37	12	14	14	ANB4	—	—	T5G ⁽¹⁾	—	—	—	IOCB4	—	—	—	Y	—
RB5	38	13	15	15	ANB5	—	—	T1G ⁽¹⁾	—	—	—	IOCB5	—	—	—	Y	—
RB6	39	14	16	16	ANB6	—	—	—	—	—	—	IOCB6	CK2 ⁽¹⁾	—	—	Y	ICSPCLK
RB7	40	15	17	17	ANB7	DAC1OUT2	—	T6AIN ⁽¹⁾	—	—	—	IOCB7	RX2/DT2 ⁽¹⁾	—	—	Y	ICSPDAT
RC0	15	30	34	32	ANC0	—	—	T1CKI ⁽¹⁾ T3CKI ⁽¹⁾ T3G ⁽¹⁾	—	—	—	IOCC0	—	—	—	Y	SOSCO
RC1	16	31	35	35	ANC1	—	—	—	CCP2 ⁽¹⁾	—	—	IOCC1	—	—	—	Y	SOSCIN SOSCI

- Note**
- 1: Default peripheral input. Input can be moved to any other pin with the PPS input selection registers ([Register 17-1](#)).
 - 2: All pin outputs default to PORT latch data. Any pin can be selected as a peripheral digital output with the PPS output selection registers.
 - 3: These peripheral functions are bidirectional. The output pin selections must be the same as the input pin selections.
 - 4: These pins are configured for I2C logic levels; The SCLx/SDAx signals may be assigned to any of these pins. PPS assignments to the other pins (e.g., RB1) will operate, but input logic levels will be standard TTL/ST as selected by the INLVL register, instead of the I2C specific or SMBus input buffer thresholds.

TABLE 2: 40/44-PIN ALLOCATION TABLE (PIC18(L)F47K40) (CONTINUED)

I/O ⁽²⁾	40-Pin PDIP	40-Pin UQFN	44-Pin QFN	44-Pin TQFP	A/D	Reference	Comparator	Timers	CCP	CWG	ZCD	Interrupt	EUSART	DSM	MSSP	Pull-up	Basic	
RC2	17	32	36	36	ANC2	—	—	T5CKI ⁽¹⁾	CCP1 ⁽¹⁾	—	—	IOCC2	—	—	—	Y	—	
RC3	18	33	37	37	ANC3	—	—	T2AIN ⁽¹⁾	—	—	—	IOCC3	—	—	SCK1 ⁽¹⁾ SCL1 ^(3,4)	Y	—	
RC4	23	38	42	42	ANC4	—	—	—	—	—	—	IOCC4	—	—	SDI1 ⁽¹⁾ SDA1 ^(3,4)	—	—	
RC5	24	39	43	43	ANC5	—	—	T4AIN ⁽¹⁾	—	—	—	IOCC5	—	—	—	Y	—	
RC6	25	40	44	44	ANC6	—	—	—	—	—	—	IOCC6	CK1 ⁽¹⁾	—	—	Y	—	
RC7	26	1	1	1	ANC7	—	—	—	—	—	—	IOCC7	RX1/DT1 ⁽¹⁾	—	—	Y	—	
RD0	19	34	38	38	AND0	—	—	—	—	—	—	IOCD0	—	—	—	Y	—	
RD1	20	35	39	39	AND1	—	—	—	—	—	—	IOCD1	—	—	—	Y	—	
RD2	21	36	40	40	AND2	—	—	—	—	—	—	IOCD2	—	—	—	Y	—	
RD3	22	37	41	41	AND3	—	—	—	—	—	—	IOCD3	—	—	—	Y	—	
RD4	27	2	2	2	AND4	—	—	—	—	—	—	IOCD4	—	—	—	Y	—	
RD5	28	3	3	3	AND5	—	—	—	—	—	—	IOCD5	—	—	—	Y	—	
RD6	29	4	4	4	AND6	—	—	—	—	—	—	IOCD6	—	—	—	Y	—	
RD7	30	5	5	5	AND7	—	—	—	—	—	—	IOCD7	—	—	—	Y	—	
RE0	8	23	25	25	ANE0	—	—	—	—	—	—	—	—	—	—	Y	—	
RE1	9	24	26	26	ANE1	—	—	—	—	—	—	—	—	—	—	Y	—	
RE2	10	25	27	27	ANE2	—	—	—	—	—	—	—	—	—	—	Y	—	
RE3	1	16	18	18	—	—	—	—	—	—	—	IOCE3	—	—	—	Y	V _{PP} /MCLR	
Vss	12	6	6	6	—	—	—	—	—	—	—	—	—	—	—	—	—	Vss
Vdd	11	7	7	7	—	—	—	—	—	—	—	—	—	—	—	—	—	VDD
Vdd	32	26	28	28	—	—	—	—	—	—	—	—	—	—	—	—	—	VDD
Vss	31	27	30	29	—	—	—	—	—	—	—	—	—	—	—	—	—	Vss
OUT ⁽²⁾	—	—	ADGRDA ADGRDB	—	C1OUT C2OUT	TMR0	CCP1 CCP2 PWM3 PWM4	CWG1A CWG1B CWG1C CWG1D	—	—	TX1/ CK1 ⁽³⁾ DT1 ⁽³⁾ TX2/ CK2 ⁽³⁾ DT2 ⁽³⁾	DSM	SDO1 SCK1 SDO2 SCK2	—	—	—	OUT ⁽²⁾	—

- Note**
- 1: Default peripheral input. Input can be moved to any other pin with the PPS input selection registers ([Register 17-1](#)).
 - 2: All pin outputs default to PORT latch data. Any pin can be selected as a peripheral digital output with the PPS output selection registers.
 - 3: These peripheral functions are bidirectional. The output pin selections must be the same as the input pin selections.
 - 4: These pins are configured for I2C logic levels; The SCLx/SDAx signals may be assigned to any of these pins. PPS assignments to the other pins (e.g., RB1) will operate, but input logic levels will be standard TTL/ST as selected by the INLVL register, instead of the I2C specific or SMBus input buffer thresholds.

Table of Contents

1.0	Device Overview	13
2.0	Guidelines for Getting Started with PIC18(L)F27/47K40 Microcontrollers	18
3.0	Device Configuration	21
4.0	Oscillator Module (with Fail-Safe Clock Monitor)	34
5.0	Reference Clock Output Module	53
6.0	Power-Saving Operation Modes	58
7.0	Peripheral Module Disable (PMD)	67
8.0	Resets	74
9.0	Windowed Watchdog Timer (WWDT)	83
10.0	Memory Organization	92
11.0	Nonvolatile Memory (NVM) Control	124
12.0	8x8 Hardware Multiplier	148
13.0	Cyclic Redundancy Check (CRC) Module with Memory Scanner	150
14.0	Interrupts	167
15.0	I/O Ports	197
16.0	Interrupt-on-Change	209
17.0	Peripheral Pin Select (PPS) Module	213
18.0	Timer0 Module	221
19.0	Timer1/3/5 Module with Gate Control	227
20.0	Timer2/4/6 Module	243
21.0	Capture/Compare/PWM Module	267
22.0	Pulse-Width Modulation (PWM)	281
23.0	Zero-Cross Detection (ZCD) Module	289
24.0	Complementary Waveform Generator (CWG) Module	296
25.0	Data Signal Modulator (DSM) Module	323
26.0	Master Synchronous Serial Port Module	334
27.0	Enhanced Universal Synchronous Asynchronous Receiver Transmitter (EUSART)	391
28.0	Fixed Voltage Reference (FVR)	422
29.0	Temperature Indicator Module	424
30.0	5-Bit Digital-to-Analog Converter (DAC) Module	426
31.0	Analog-to-Digital Converter with Computation (ADC2) Module	430
32.0	Comparator Module	466
33.0	High/Low-Voltage Detect (HLVD)	476
34.0	In-Circuit Serial Programming™ (ICSP™)	483
35.0	Instruction Set Summary	485
36.0	Development Support	535
37.0	Electrical Specifications	539
38.0	DC and AC Characteristics Graphs and Tables	569
39.0	Packaging Information	570
	Appendix A: Revision History	594
	Appendix B: Device Differences	595
	The Microchip Website	596
	Customer Change Notification Service	596
	Customer Support	596
	Product Identification System	597

TO OUR VALUED CUSTOMERS

It is our intention to provide our valued customers with the best documentation possible to ensure successful use of your Microchip products. To this end, we will continue to improve our publications to better suit your needs. Our publications will be refined and enhanced as new volumes and updates are introduced.

If you have any questions or comments regarding this publication, please contact the Marketing Communications Department via E-mail at docerrors@microchip.com. We welcome your feedback.

Most Current Data Sheet

To obtain the most up-to-date version of this data sheet, please register at our Worldwide Website at:

<http://www.microchip.com>

You can determine the version of a data sheet by examining its literature number found on the bottom outside corner of any page. The last character of the literature number is the version number, (e.g., DS30000000A is version A of document DS30000000).

Errata

An errata sheet, describing minor operational differences from the data sheet and recommended workarounds, may exist for current devices. As device/documentation issues become known to us, we will publish an errata sheet. The errata will specify the revision of silicon and revision of document to which it applies.

To determine if an errata sheet exists for a particular device, please check with one of the following:

- Microchip's Worldwide Website; <http://www.microchip.com>
- Your local Microchip sales office (see last page)

When contacting a sales office, please specify which device, revision of silicon and data sheet (include literature number) you are using.

Customer Notification System

Register on our website at www.microchip.com to receive the most current information on all of our products.

1.0 DEVICE OVERVIEW

This document contains device specific information for the following devices:

- PIC18F27K40
- PIC18F47K40
- PIC18LF27K40
- PIC18LF47K40

This family offers the advantages of all PIC18 microcontrollers – namely, high computational performance at an economical price – with the addition of high-endurance, Program Flash Memory. In addition to these features, the PIC18(L)F2x/4xK40 family introduces design enhancements that make these microcontrollers a logical choice for many high-performance, power sensitive applications.

1.1 New Core Features

1.1.1 XLP TECHNOLOGY

All of the devices in the PIC18(L)F2x/4xK40 family incorporate a range of features that can significantly reduce power consumption during operation. Key items include:

- **Alternate Run Modes:** By clocking the controller from the secondary oscillator or the internal oscillator block, power consumption during code execution can be reduced by as much as 90%.
- **Multiple Idle Modes:** The controller can also run with its CPU core disabled but the peripherals still active. In these states, power consumption can be reduced even further, to as little as 4% of normal operation requirements.
- **On-the-fly Mode Switching:** The power-managed modes are invoked by user code during operation, allowing the user to incorporate power-saving ideas into their application's software design.
- **Peripheral Module Disable:** Modules that are not being used in the code can be selectively disabled using the PMD module. This further reduces the power consumption.

1.1.2 MULTIPLE OSCILLATOR OPTIONS AND FEATURES

All of the devices in the PIC18(L)F2x/4xK40 family offer several different oscillator options. The PIC18(L)F2x/4xK40 family can be clocked from several different sources:

- HFINTOSC
 - 1-64 MHz precision digitally controlled internal oscillator
- LFINTOSC
 - 31 kHz internal oscillator
- EXTOSC
 - External clock (EC)
 - Low-power oscillator (LP)
 - Medium power oscillator (XT)
 - High-power oscillator (HS)
- SOSC
 - Secondary oscillator circuit operating at 31 kHz
- A Phase Lock Loop (PLL) frequency multiplier (4x) is available to the External Oscillator modes enabling clock speeds of up to 64 MHz
- Fail-Safe Clock Monitor: This option constantly monitors the main clock source against a reference signal provided by the LFINTOSC. If a clock failure occurs, the controller is switched to the internal oscillator block, allowing for continued operation or a safe application shutdown.

1.2 Other Special Features

- **Memory Endurance:** The Flash cells for both program memory and data EEPROM are rated to last for many thousands of erase/write cycles – up to 10K for program memory and 100K for EEPROM. Data retention without refresh is conservatively estimated to be greater than 40 years.
- **Self-programmability:** These devices can write to their own program memory spaces under internal software control. By using a boot loader routine located in the protected Boot Block at the top of program memory, it becomes possible to create an application that can update itself in the field.
- **Extended Instruction Set:** The PIC18(L)F2x/4xK40 family introduces an optional extension to the PIC18 instruction set, which adds eight new instructions and an Indexed Addressing mode. This extension, enabled as a device configuration option, has been specifically designed to optimize re-entrant application code originally developed in high-level languages, such as C.
- **Enhanced Peripheral Pin Select:** The Peripheral Pin Select (PPS) module connects peripheral inputs and outputs to the device I/O pins. Only digital signals are included in the selections. All analog inputs and outputs remain fixed to their assigned pins.
- **Enhanced Addressable EUSART:** This serial communication module is capable of standard RS-232 operation and provides support for the LIN bus protocol. Other enhancements include automatic baud rate detection and a 16-bit Baud Rate Generator for improved resolution. When the microcontroller is using the internal oscillator block, the EUSART provides stable operation for applications that talk to the outside world without using an external crystal (or its accompanying power requirement).
- **10-bit A/D Converter with Computation:** This module incorporates programmable acquisition time, allowing for a channel to be selected and a conversion to be initiated without waiting for a sampling period and thus, reduce code overhead. It has a new module called ADC² with computation features, which provides a digital filter and threshold interrupt functions.
- **Windowed Watchdog Timer (WWDT):**
 - Timer monitoring of overflow and underflow events
 - Variable prescaler selection
 - Variable window size selection
 - All sources configurable in hardware or software

1.3 Details on Individual Family Members

Devices in the PIC18(L)F2x/4xK40 family are available in 28-pin and 40/44-pin packages. The block diagram for this device is shown in [Figure 1-1](#).

The devices have the following differences:

1. Program Flash Memory
2. Data Memory SRAM
3. Data Memory EEPROM
4. A/D channels
5. I/O ports
6. Enhanced USART
7. Input Voltage Range/Power Consumption

All other features for devices in this family are identical. These are summarized in [Table 1-1](#).

The pinouts for all devices are listed in the pin summary tables ([Table 1](#) and [Table 2](#)).

PIC18(L)F27/47K40

TABLE 1-1: DEVICE FEATURES

Features	PIC18(L)F27K40	PIC18(L)F47K40
Program Memory (Bytes)	131072	131072
Program Memory (Instructions)	65536	65536
Data Memory (Bytes)	3720	3720
Data EEPROM Memory (Bytes)	1024	1024
I/O Ports	A,B,C,E ⁽¹⁾	A,B,C,D,E ⁽¹⁾
Capture/Compare/PWM Modules (CCP)	2	2
10-Bit Pulse-Width Modulator (PWM)	2	2
10-Bit Analog-to-Digital Module (ADC ²) with Computation Accelerator	4 internal 24 external	4 internal 35 external
Packages	28-pin SPDIP 28-pin SOIC 28-pin SSOP 28-pin QFN	40-pin PDIP 40-pin UQFN 44-pin QFN 44-pin TQFP
Interrupt Sources	36	
Timers (16-/8-bit)	4/3	
Serial Communications	2 MSSP, 2 EUSART	
Enhanced Complementary Waveform Generator (ECWG)	1	
Zero-Cross Detect (ZCD)	1	
Data Signal Modulator (DSM)	1	
Peripheral Pin Select (PPS)	Yes	
Peripheral Module Disable (PMD)	Yes	
16-bit CRC with NVMSCAN	Yes	
Programmable High/Low-Voltage Detect (HLVD)	Yes	
Programmable Brown-out Reset (BOR)	Yes	
Resets (and Delays)	POR, BOR, RESET Instruction, Stack Overflow, Stack Underflow (PWRT, OST), MCLR, WDT	
Instruction Set	75 Instructions; 83 with Extended Instruction Set enabled	
Operating Frequency	DC – 64 MHz	

Note 1: PORTE contains the single RE3 input-only pin.

PIC18(L)F27/47K40

FIGURE 1-1: PIC18(L)F2X/4XK40 FAMILY BLOCK DIAGRAM

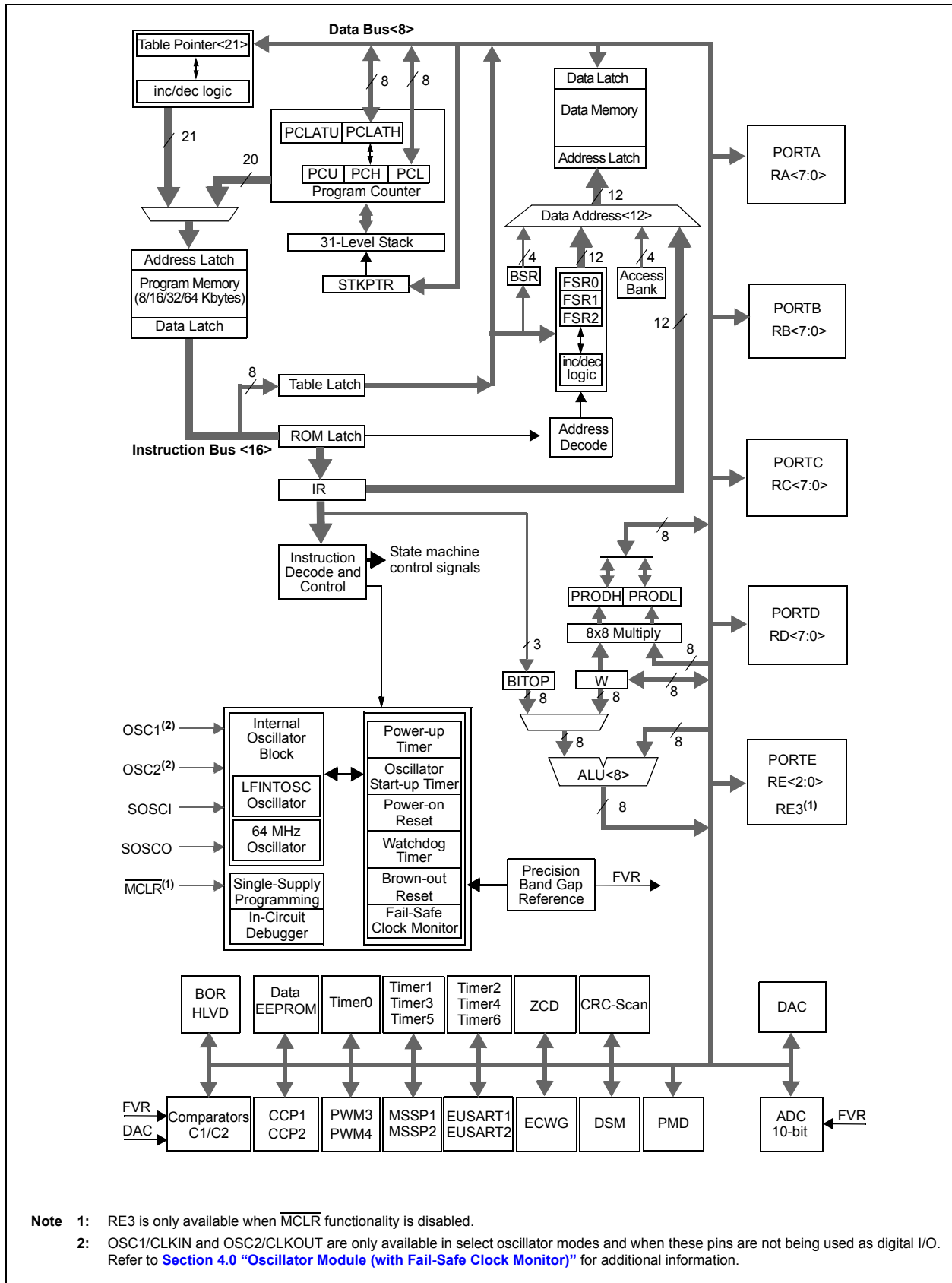

1.4 Register and Bit naming conventions

1.4.1 REGISTER NAMES

When there are multiple instances of the same peripheral in a device, the peripheral control registers will be depicted as the concatenation of a peripheral identifier, peripheral instance, and control identifier. The control registers section will show just one instance of all the register names with an 'x' in the place of the peripheral instance number. This naming convention may also be applied to peripherals when there is only one instance of that peripheral in the device to maintain compatibility with other devices in the family that contain more than one.

1.4.2 BIT NAMES

There are two variants for bit names:

- Short name: Bit function abbreviation
- Long name: Peripheral abbreviation + short name

1.4.2.1 Short Bit Names

Short bit names are an abbreviation for the bit function. For example, some peripherals are enabled with the EN bit. The bit names shown in the registers are the short name variant.

Short bit names are useful when accessing bits in C programs. The general format for accessing bits by the short name is *RegisterName*bits.*ShortName*. For example, the enable bit, EN, in the COG1CON0 register can be set in C programs with the instruction `COG1CON0bits.EN = 1`.

Short names are generally not useful in assembly programs because the same name may be used by different peripherals in different bit positions. When this occurs, during the include file generation, all instances of that short bit name are appended with an underscore plus the name of the register in which the bit resides to avoid naming contentions.

1.4.2.2 Long Bit Names

Long bit names are constructed by adding a peripheral abbreviation prefix to the short name. The prefix is unique to the peripheral thereby making every long bit name unique. The long bit name for the COG1 enable bit is the COG1 prefix, G1, appended with the enable bit short name, EN, resulting in the unique bit name G1EN.

Long bit names are useful in both C and assembly programs. For example, in C the COG1CON0 enable bit can be set with the `G1EN = 1` instruction. In assembly, this bit can be set with the `BSF COG1CON0,G1EN` instruction.

1.4.2.3 Bit Fields

Bit fields are two or more adjacent bits in the same register. Bit fields adhere only to the short bit naming convention. For example, the three Least Significant bits of the COG1CON0 register contain the mode control bits. The short name for this field is MD. There is no long bit name variant. Bit field access is only possible in C programs. The following example demonstrates a C program instruction for setting the COG1 to the Push-Pull mode:

```
COG1CON0bits.MD = 0x5;
```

Individual bits in a bit field can also be accessed with long and short bit names. Each bit is the field name appended with the number of the bit position within the field. For example, the Most Significant mode bit has the short bit name MD2 and the long bit name is G1MD2. The following two examples demonstrate assembly program sequences for setting the COG1 to Push-Pull mode:

Example 1:

```
MOVLW  ~(1<<G1MD1)
ANDWF  COG1CON0,F
MOVLW  1<<G1MD2 | 1<<G1MD0
IORWF  COG1CON0,F
```

Example 2:

```
BSF    COG1CON0,G1MD2
BCF    COG1CON0,G1MD1
BSF    COG1CON0,G1MD0
```

1.4.3 REGISTER AND BIT NAMING EXCEPTIONS

1.4.3.1 Status, Interrupt, and Mirror Bits

Status, interrupt enables, interrupt flags, and mirror bits are contained in registers that span more than one peripheral. In these cases, the bit name shown is unique so there is no prefix or short name variant.

1.4.3.2 Legacy Peripherals

There are some peripherals that do not strictly adhere to these naming conventions. Peripherals that have existed for many years and are present in almost every device are the exceptions. These exceptions were necessary to limit the adverse impact of the new conventions on legacy code. Peripherals that do adhere to the new convention will include a table in the registers section indicating the long name prefix for each peripheral instance. Peripherals that fall into the exception category will not have this table. These peripherals include, but are not limited to, the following:

- EUSART
- MSSP

2.0 GUIDELINES FOR GETTING STARTED WITH PIC18(L)F27/47K40 MICROCONTROLLERS

2.1 Basic Connection Requirements

Getting started with the PIC18(L)F27/47K40 family of 8-bit microcontrollers requires attention to a minimal set of device pin connections before proceeding with development.

The following pins must always be connected:

- All VDD and VSS pins (see [Section 2.2 “Power Supply Pins”](#))
- MCLR pin (see [Section 2.3 “Master Clear \(MCLR\) Pin”](#))

These pins must also be connected if they are being used in the end application:

- PGC/PGD pins used for In-Circuit Serial Programming™ (ICSP™) and debugging purposes (see [Section 2.4 “ICSP™ Pins”](#))
- OSCI and OSCO pins when an external oscillator source is used (see [Section 2.5 “External Oscillator Pins”](#))

Additionally, the following pins may be required:

- VREF+/VREF- pins are used when external voltage reference for analog modules is implemented

The minimum mandatory connections are shown in [Figure 2-1](#).

FIGURE 2-1: RECOMMENDED MINIMUM CONNECTIONS

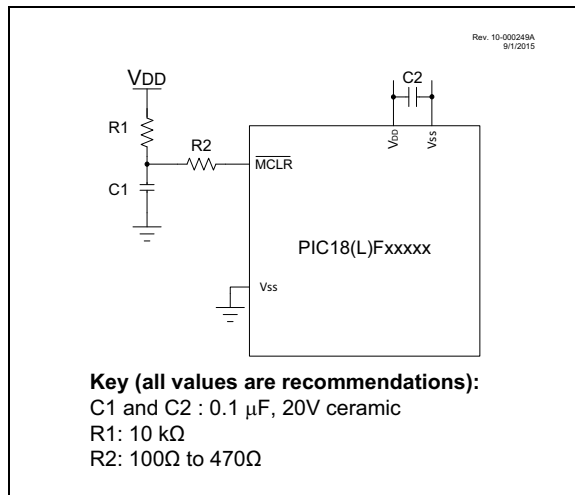

2.2 Power Supply Pins

2.2.1 DECOUPLING CAPACITORS

The use of decoupling capacitors on every pair of power supply pins (VDD and VSS) is required.

Consider the following criteria when using decoupling capacitors:

- **Value and type of capacitor:** A 0.1 μ F (100 nF), 10-20V capacitor is recommended. The capacitor should be a low-ESR device, with a resonance frequency in the range of 200 MHz and higher. Ceramic capacitors are recommended.
- **Placement on the printed circuit board:** The decoupling capacitors should be placed as close to the pins as possible. It is recommended to place the capacitors on the same side of the board as the device. If space is constricted, the capacitor can be placed on another layer on the PCB using a via; however, ensure that the trace length from the pin to the capacitor is no greater than 0.25 inch (6 mm).
- **Handling high-frequency noise:** If the board is experiencing high-frequency noise (upward of tens of MHz), add a second ceramic type capacitor in parallel to the above described decoupling capacitor. The value of the second capacitor can be in the range of 0.01 μ F to 0.001 μ F. Place this second capacitor next to each primary decoupling capacitor. In high-speed circuit designs, consider implementing a decade pair of capacitances as close to the power and ground pins as possible (e.g., 0.1 μ F in parallel with 0.001 μ F).
- **Maximizing performance:** On the board layout from the power supply circuit, run the power and return traces to the decoupling capacitors first, and then to the device pins. This ensures that the decoupling capacitors are first in the power chain. Equally important is to keep the trace length between the capacitor and the power pins to a minimum, thereby reducing PCB trace inductance.

2.2.2 TANK CAPACITORS

On boards with power traces running longer than six inches in length, it is suggested to use a tank capacitor for integrated circuits, including microcontrollers, to supply a local power source. The value of the tank capacitor should be determined based on the trace resistance that connects the power supply source to the device, and the maximum current drawn by the device in the application. In other words, select the tank capacitor so that it meets the acceptable voltage sag at the device. Typical values range from 4.7 μ F to 47 μ F.

2.3 Master Clear ($\overline{\text{MCLR}}$) Pin

The $\overline{\text{MCLR}}$ pin provides two specific device functions: Device Reset, and Device Programming and Debugging. If programming and debugging are not required in the end application, a direct connection to V_{DD} may be all that is required. The addition of other components, to help increase the application's resistance to spurious Resets from voltage sags, may be beneficial. A typical configuration is shown in Figure 2-1. Other circuit designs may be implemented, depending on the application's requirements.

During programming and debugging, the resistance and capacitance that can be added to the pin must be considered. Device programmers and debuggers drive the $\overline{\text{MCLR}}$ pin. Consequently, specific voltage levels (V_{IH} and V_{IL}) and fast signal transitions must not be adversely affected. Therefore, specific values of $R1$ and $C1$ will need to be adjusted based on the application and PCB requirements. For example, it is recommended that the capacitor, $C1$, be isolated from the $\overline{\text{MCLR}}$ pin during programming and debugging operations by using a jumper (Figure 2-2). The jumper is replaced for normal run-time operations.

Any components associated with the $\overline{\text{MCLR}}$ pin should be placed within 0.25 inch (6 mm) of the pin.

2.4 ICSP™ Pins

The PGC and PGD pins are used for In-Circuit Serial Programming™ (ICSP™) and debugging purposes. It is recommended to keep the trace length between the ICSP connector and the ICSP pins on the device as short as possible. If the ICSP connector is expected to experience an ESD event, a series resistor is recommended, with the value in the range of a few tens of ohms, not to exceed 100Ω.

Pull-up resistors, series diodes and capacitors on the PGC and PGD pins are not recommended as they will interfere with the programmer/debugger communications to the device. If such discrete components are an application requirement, they should be removed from the circuit during programming and debugging. Alternatively, refer to the AC/DC characteristics and timing requirements information in the respective device Flash programming specification for information on capacitive loading limits, and pin input voltage high (V_{IH}) and input low (V_{IL}) requirements.

For device emulation, ensure that the “Communication Channel Select” (i.e., PGCx/PGDx pins), programmed into the device, matches the physical connections for the ICSP to the Microchip debugger/emulator tool.

For more information on available Microchip development tools connection requirements, refer to [Section 36.0 “Development Support”](#).

FIGURE 2-2: EXAMPLE OF $\overline{\text{MCLR}}$ PIN CONNECTIONS

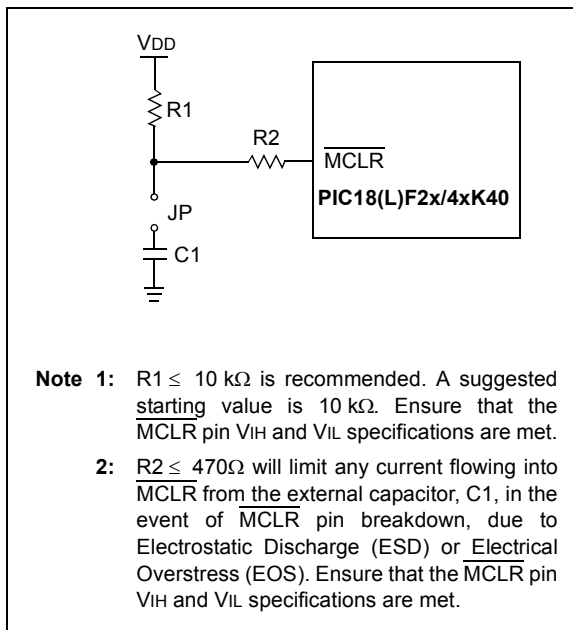

2.5 External Oscillator Pins

Many microcontrollers have options for at least two oscillators: a high-frequency primary oscillator and a low-frequency secondary oscillator (refer to [Section 4.0 “Oscillator Module \(with Fail-Safe Clock Monitor\)”](#) for details).

The oscillator circuit should be placed on the same side of the board as the device. Place the oscillator circuit close to the respective oscillator pins with no more than 0.5 inch (12 mm) between the circuit components and the pins. The load capacitors should be placed next to the oscillator itself, on the same side of the board.

Use a grounded copper pour around the oscillator circuit to isolate it from surrounding circuits. The grounded copper pour should be routed directly to the MCU ground. Do not run any signal traces or power traces inside the ground pour. Also, if using a two-sided board, avoid any traces on the other side of the board where the crystal is placed.

Layout suggestions are shown in [Figure 2-3](#). In-line packages may be handled with a single-sided layout that completely encompasses the oscillator pins. With fine-pitch packages, it is not always possible to completely surround the pins and components. A suitable solution is to tie the broken guard sections to a mirrored ground layer. In all cases, the guard trace(s) must be returned to ground.

In planning the application's routing and I/O assignments, ensure that adjacent port pins, and other signals in close proximity to the oscillator, are benign (i.e., free of high frequencies, short rise and fall times, and other similar noise).

For additional information and design guidance on oscillator circuits, please refer to these Microchip Application Notes, available at the corporate website (www.microchip.com):

- AN826, “Crystal Oscillator Basics and Crystal Selection for rPIC™ and PICmicro® Devices”
- AN849, “Basic PICmicro® Oscillator Design”
- AN943, “Practical PICmicro® Oscillator Analysis and Design”
- AN949, “Making Your Oscillator Work”

2.6 Unused I/Os

Unused I/O pins should be configured as outputs and driven to a logic low state. Alternatively, connect a 1 kΩ to 10 kΩ resistor to Vss on unused pins and drive the output to logic low.

FIGURE 2-3: SUGGESTED PLACEMENT OF THE OSCILLATOR CIRCUIT

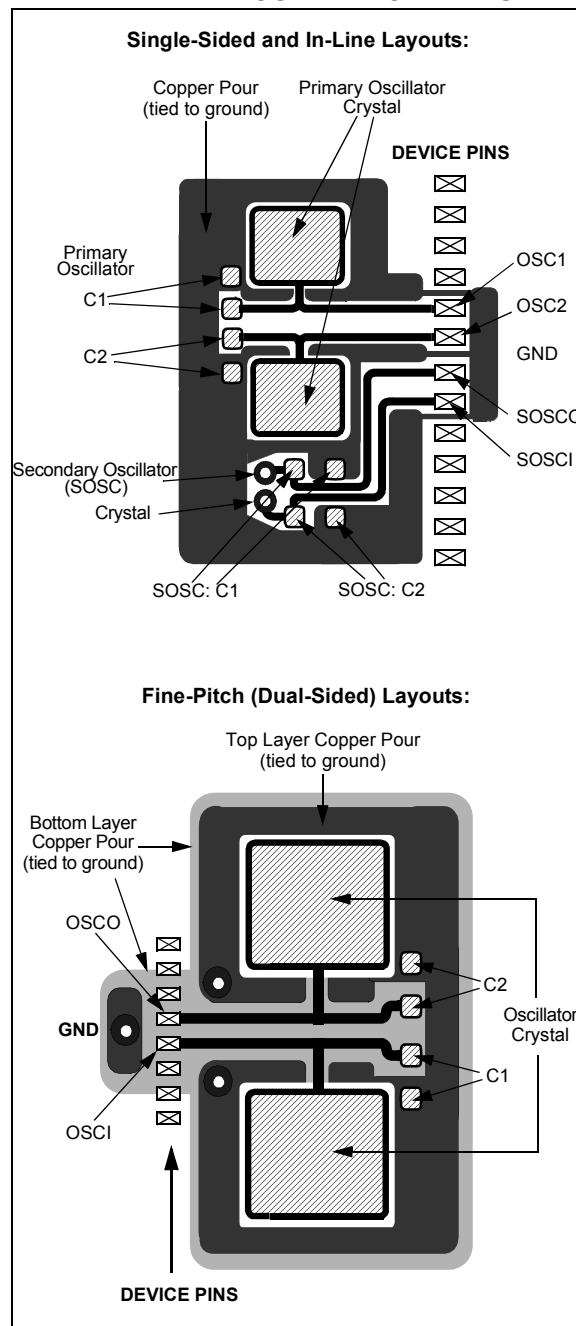

3.0 DEVICE CONFIGURATION

Device configuration consists of Configuration Words, Code Protection, Device ID and Rev ID.

3.1 Configuration Words

There are six Configuration Word bits that allow the user to setup the device with several choices of oscillators, Resets and memory protection options. These are implemented as Configuration Word 1 through Configuration Word 6 at 300000h through 30000Bh.

Note: The `DEBUG` bit in Configuration Words is managed automatically by device development tools including debuggers and programmers. For normal device operation, this bit should be maintained as a '1'.

3.2 Register Definitions: Configuration Words

REGISTER 3-1: Configuration Word 1L (30 0000h): Oscillators

U-1	R/W-1	R/W-1	R/W-1	U-1	R/W-1	R/W-1	R/W-1
—	RSTOSC<2:0>			—	FEXTOSC<2:0>		
bit 7				bit 0			

Legend:

R = Readable bit	W = Writable bit	U = Unimplemented bit, read as '1'
-n = Value for blank device	'1' = Bit is set	'0' = Bit is cleared
		x = Bit is unknown

bit 7 **Unimplemented:** Read as '1'

bit 6-4 **RSTOSC<2:0>:** Power-up Default Value for COSC bits
 This value is the Reset default value for COSC and selects the oscillator first used by user software. Refer to COSC operation.
 111 = EXTOSC operating per FEXTOSC bits (device manufacturing default)
 110 = HFINTOSC with HFFRQ = 4 MHz (Register 4-5) and CDIV = 4:1 (Register 4-2)
 101 = LFINTOSC
 100 = SOSC
 011 = Reserved
 010 = EXTOSC with 4x PLL, with EXTOSC operating per FEXTOSC bits
 001 = Reserved
 000 = HFINTOSC with HFFRQ = 64 MHz (Register 4-5) and CDIV = 1:1 (Register 4-2). Resets COSC/NOSC to 3'b110.

bit 3 **Unimplemented:** Read as '1'

bit 2-0 **FEXTOSC<2:0>:** FEXTOSC External Oscillator Mode Selection bits
 111 = EC (external clock) above 8 MHz; PFM set to high power (device manufacturing default)
 110 = EC (external clock) for 500 kHz to 8 MHz; PFM set to medium power
 101 = EC (external clock) below 500 kHz; PFM set to low power
 100 = Oscillator not enabled
 011 = Reserved (do not use)
 010 = HS (crystal oscillator) above 8 MHz; PFM set to high power
 001 = XT (crystal oscillator) above 500 kHz, below 8 MHz; PFM set to medium power
 000 = LP (crystal oscillator) optimized for 32.768 kHz; PFM set to low power

PIC18(L)F27/47K40

REGISTER 3-2: Configuration Word 1H (30 0001h): Oscillators

U-1	U-1	R/W-1	U-1	R/W-1	U-1	U-1	R/W-1
—	—	FCMEN	—	CSWEN	—	—	CLKOUTEN
bit 7							bit 0

Legend:

R = Readable bit

W = Writable bit

U = Unimplemented bit, read as '1'

-n = Value for blank device

'1' = Bit is set

'0' = Bit is cleared

x = Bit is unknown

bit 7-6 **Unimplemented:** Read as '1'

bit 5 **FCMEN:** Fail-Safe Clock Monitor Enable bit
1 = FSCM timer enabled
0 = FSCM timer disabled

bit 4 **Unimplemented:** Read as '1'

bit 3 **CSWEN:** Clock Switch Enable bit
1 = Writing to NOSC and NDIV is allowed
0 = The NOSC and NDIV bits cannot be changed by user software

bit 2-1 **Unimplemented:** Read as '1'

bit 0 **CLKOUTEN:** Clock Out Enable bit
If FEXTOSC = HS, XT, LP, then this bit is ignored
Otherwise:
1 = CLKOUT function is disabled; I/O or oscillator function on OSC2
0 = CLKOUT function is enabled; FOSC/4 clock appears at OSC2

PIC18(L)F27/47K40

REGISTER 3-3: Configuration Word 2L (30 0002h): Supervisor

R/W-1	R/W-1	R/W-1	U-1	U-1	U-1	R/W-1	R/W-1
BOREN<1:0>		LPBOREN	—	—	—	PWRTE	MCLRE
bit 7							bit 0

Legend:

R = Readable bit W = Writable bit U = Unimplemented bit, read as '1'
 -n = Value for blank device '1' = Bit is set '0' = Bit is cleared x = Bit is unknown

- bit 7-6 **BOREN<1:0>**: Brown-out Reset Enable bits
 When enabled, Brown-out Reset Voltage (VBOR) is set by BORV bit
 11 = Brown-out Reset enabled, SBOREN bit is ignored
 10 = Brown-out Reset enabled while running, disabled in Sleep; SBOREN is ignored
 01 = Brown-out Reset enabled according to SBOREN
 00 = Brown-out Reset disabled
- bit 5 **LPBOREN**: Low-Power BOR Enable bit
 1 = Low-Power Brown-out Reset is disabled
 0 = Low-Power Brown-out Reset is enabled
- bit 4-2 **Unimplemented**: Read as '1'
- bit 1 **PWRTE**: Power-up Timer Enable bit
 1 = PWRT disabled
 0 = PWRT enabled
- bit 0 **MCLRE**: Master Clear ($\overline{\text{MCLR}}$) Enable bit
 If LVP = 1
 RE3 pin function is $\overline{\text{MCLR}}$
 If LVP = 0
 1 = $\overline{\text{MCLR}}$ pin is $\overline{\text{MCLR}}$
 0 = $\overline{\text{MCLR}}$ pin function is port defined function

PIC18(L)F27/47K40

REGISTER 3-4: Configuration Word 2H (30 0003h): Supervisor

R/W-1	U-1	R/W-1	R/W-1	R/W-1	R/W-1	R/W-1	R/W-1
$\overline{\text{XINST}}$	—	$\overline{\text{DEBUG}}$	STVREN	PPS1WAY	$\overline{\text{ZCD}}$	BORV<1:0>	
bit 7							bit 0

Legend:

R = Readable bit W = Writable bit U = Unimplemented bit, read as '1'
 -n = Value for blank device '1' = Bit is set '0' = Bit is cleared x = Bit is unknown

- bit 7 **$\overline{\text{XINST}}$** : Extended Instruction Set Enable bit
 1 = Extended Instruction Set and Indexed Addressing mode disabled (Legacy mode)
 0 = Extended Instruction Set and Indexed Addressing mode enabled
- bit 6 **Unimplemented**: Read as '1'
- bit 5 **$\overline{\text{DEBUG}}$** : Debugger Enable bit
 1 = Background debugger disabled
 0 = Background debugger enabled
- bit 4 **STVREN**: Stack Overflow/Underflow Reset Enable bit
 1 = Stack Overflow or Underflow will cause a Reset
 0 = Stack Overflow or Underflow will not cause a Reset
- bit 3 **PPS1WAY**: PPSLOCKED bit One-Way Set Enable bit
 1 = The PPSLOCKED bit can only be set once after an unlocking sequence is executed; once PPSLOCK is set, all future changes to PPS registers are prevented
 0 = The PPSLOCKED bit can be set and cleared as needed (provided an unlocking sequence is executed)
- bit 2 **$\overline{\text{ZCD}}$** : ZCD Disable bit
 1 = ZCD disabled. ZCD can be enabled by setting the ZCDSEN bit of ZCDCON
 0 = ZCD always enabled, ZCDMD bit is ignored
- bit 1-0 **BORV<1:0>**: Brown-out Reset Voltage Selection bit⁽¹⁾
 PIC18F2x/4xK40 device:
 11 = Brown-out Reset Voltage (VBOR) set to 2.45V
 10 = Brown-out Reset Voltage (VBOR) set to 2.45V
 01 = Brown-out Reset Voltage (VBOR) set to 2.7V
 00 = Brown-out Reset Voltage (VBOR) set to 2.85V
 PIC18LF2x/4xK40 device:
 11 = Brown-out Reset Voltage (VBOR) set to 1.90V
 10 = Brown-out Reset Voltage (VBOR) set to 2.45V
 01 = Brown-out Reset Voltage (VBOR) set to 2.7V
 00 = Brown-out Reset Voltage (VBOR) set to 2.85V

Note 1: The higher voltage setting is recommended for operation at or above 16 MHz.