



Chipsmall Limited consists of a professional team with an average of over 10 year of expertise in the distribution of electronic components. Based in Hongkong, we have already established firm and mutual-benefit business relationships with customers from,Europe,America and south Asia,supplying obsolete and hard-to-find components to meet their specific needs.

With the principle of “Quality Parts,Customers Priority,Honest Operation,and Considerate Service”,our business mainly focus on the distribution of electronic components. Line cards we deal with include Microchip,ALPS,ROHM,Xilinx,Pulse,ON,Everlight and Freescale. Main products comprise IC,Modules,Potentiometer,IC Socket,Relay,Connector.Our parts cover such applications as commercial,industrial, and automotives areas.

We are looking forward to setting up business relationship with you and hope to provide you with the best service and solution. Let us make a better world for our industry!



Contact us

Tel: +86-755-8981 8866 Fax: +86-755-8427 6832

Email & Skype: info@chipsmall.com Web: www.chipsmall.com

Address: A1208, Overseas Decoration Building, #122 Zhenhua RD., Futian, Shenzhen, China





PIC24FJ128GA204 FAMILY

28/44-Pin, General Purpose, 16-Bit Flash Microcontrollers with Cryptographic Engine, ISO 7816 and XLP Technology

Cryptographic Engine

- AES Engine with 128, 192 or 256-Bit Key
- Supports ECB, CBC, OFB, CTR and CFB128 modes
- DES/Triple DES (TDES) Engine: Supports 2-Key and 3-Key EDE or DED TDES
- Supports up to Three Unique Keys for TDES
- Programmatically Secure
- Pseudorandom Number Generator
- True Random Number Generator
- Non-Readable, On-Chip, OTP Key Storages

Extreme Low-Power Features

- Multiple Power Management Options for Extreme Power Reduction:
 - VBAT allows the device to transition to a backup battery for the lowest power consumption with RTCC
 - Deep Sleep allows near total power-down with the ability to wake-up on internal or external triggers
 - Sleep and Idle modes selectively shut down peripherals and/or core for substantial power reduction and fast wake-up
 - Doze mode allows CPU to run at a lower clock speed than peripherals

Extreme Low-Power Features (Continued)

- Alternate Clock modes allow On-the-Fly Switching to a Lower Clock Speed for Selective Power Reduction
- Extreme Low-Power Current Consumption for Deep Sleep:
 - WDT: 270 nA @ 3.3V typical
 - RTCC: 400 nA @ 32 kHz, 3.3V typical
 - Deep Sleep current: 40 nA, 3.3V typical

Analog Features

- 10/12-Bit, 13-Channel Analog-to-Digital (A/D) Converter:
 - Conversion rate of 500 ksps (10-bit), 200 ksps (12-bit)
 - Conversion available during Sleep and Idle
- Three Rail-to-Rail, Enhanced Analog Comparators with Programmable Input/Output Configuration
- Three On-Chip Programmable Voltage References
- Charge Time Measurement Unit (CTMU):
 - Used for capacitive touch sensing, up to 13 channels
 - Time measurement down to 100 ps resolution
 - Operation in Sleep mode

Device	Memory		Pins	Analog Peripherals			Digital Peripherals						Deep Sleep w/VBAT	AES/DES Cryptographic	
	Program Flash (bytes)	Data RAM (bytes)		10/12-Bit A/D (ch)	Comparators	CTMU (ch)	Input Capture	Output Compare/PWM	I ² C™	SPI	UART w/IrDA® 7816	EPMP/PSP			16-Bit Timers
PIC24FJ128GA204	128K	8K	44	13	3	13	6	6	2	3	4	Y	5	Y	Y
PIC24FJ128GA202	128K	8K	28	10	3	10	6	6	2	3	4	N	5	Y	Y
PIC24FJ64GA204	64K	8K	44	13	3	13	6	6	2	3	4	Y	5	Y	Y
PIC24FJ64GA202	64K	8K	28	10	3	10	6	6	2	3	4	N	5	Y	Y

PIC24FJ128GA204 FAMILY

Peripheral Features

- Up to Five External Interrupt Sources
- Peripheral Pin Select (PPS); Allows Independent I/O Mapping of Many Peripherals
- Five 16-Bit Timers/Counters with Prescaler:
 - Can be paired as 32-bit timers/counters
- Six-Channel DMA supports All Peripheral modules:
 - Minimizes CPU overhead and increases data throughput
- Six Input Capture modules, Each with a Dedicated 16-Bit Timer
- Six Output Compare/PWM modules, Each with a Dedicated 16-Bit Timer
- Enhanced Parallel Master/Slave Port (EPMP/EPSP)
- Hardware Real-Time Clock/Calendar (RTCC):
 - Runs in Sleep, Deep Sleep and VBAT modes
- Three 3-Wire/4-Wire SPI modules:
 - Support four Frame modes
 - Variable FIFO buffer
 - I²S mode
 - Variable width from 2-bit to 32-bit
- Two I²C™ modules Support Multi-Master/Slave mode and 7-Bit/10-Bit Addressing
- Four UART modules:
 - Support RS-485, RS-232 and LIN/J2602
 - On-chip hardware encoder/decoder for IrDA®
 - Smart Card ISO 7816 support on UART1 and UART2 only:
 - T = 0 protocol with automatic error handling
 - T = 1 protocol
 - Dedicated Guard Time Counter (GTC)
 - Dedicated Waiting Time Counter (WTC)
 - Auto-wake-up on Auto-Baud Detect (ABD)
 - 4-level deep FIFO buffer
- Programmable 32-Bit Cyclic Redundancy Check (CRC) Generator
- Digital Signal Modulator provides On-Chip FSK and PSK Modulation for a Digital Signal Stream
- High-Current Sink/Source (18 mA/18 mA) on All I/O Pins
- Configurable Open-Drain Outputs on Digital I/O Pins
- 5.5V Tolerant Inputs on Most Pins

High-Performance CPU

- Modified Harvard Architecture
- Up to 16 MIPS Operation @ 32 MHz
- 8 MHz Internal Oscillator:
 - 96 MHz PLL option
 - Multiple clock divide options
 - Run-time self-calibration capability for maintaining better than ±0.20% accuracy
 - Fast start-up
- 17-Bit x 17-Bit Single-Cycle Hardware Fractional/Integer Multiplier
- 32-Bit by 16-Bit Hardware Divider
- 16 x 16-Bit Working Register Array
- C Compiler Optimized Instruction Set Architecture (ISA)
- Two Address Generation Units (AGUs) for Separate Read and Write Addressing of Data Memory

Special Microcontroller Features

- Supply Voltage Range of 2.0V to 3.6V
- Two On-Chip Voltage Regulators (1.8V and 1.2V) for Regular and Extreme Low-Power Operation
- 20,000 Erase/Write Cycle Endurance Flash Program Memory, Typical
- Flash Data Retention: 20 Years Minimum
- Self-Programmable under Software Control
- Programmable Reference Clock Output
- In-Circuit Serial Programming™ (ICSP™) and In-Circuit Emulation (ICE) via 2 Pins
- JTAG Programming and Boundary Scan Support
- Fail-Safe Clock Monitor (FSCM) Operation:
 - Detects clock failure and switches to on-chip, Low-Power RC Oscillator (LPRC)
- Power-on Reset (POR), Power-up Timer (PWRT) and Oscillator Start-up Timer (OST)
- Separate Brown-out Reset (BOR) and Deep Sleep Brown-out Reset (DSBOR) Circuits
- Programmable High/Low-Voltage Detect (HLVD)
- Flexible Watchdog Timer (WDT) with its Own RC Oscillator for Reliable Operation
- Standard and Ultra Low-Power Watchdog Timers (ULPWs) for Reliable Operation in Standard and Deep Sleep modes

PIC24FJ128GA204 FAMILY

Pin Diagrams

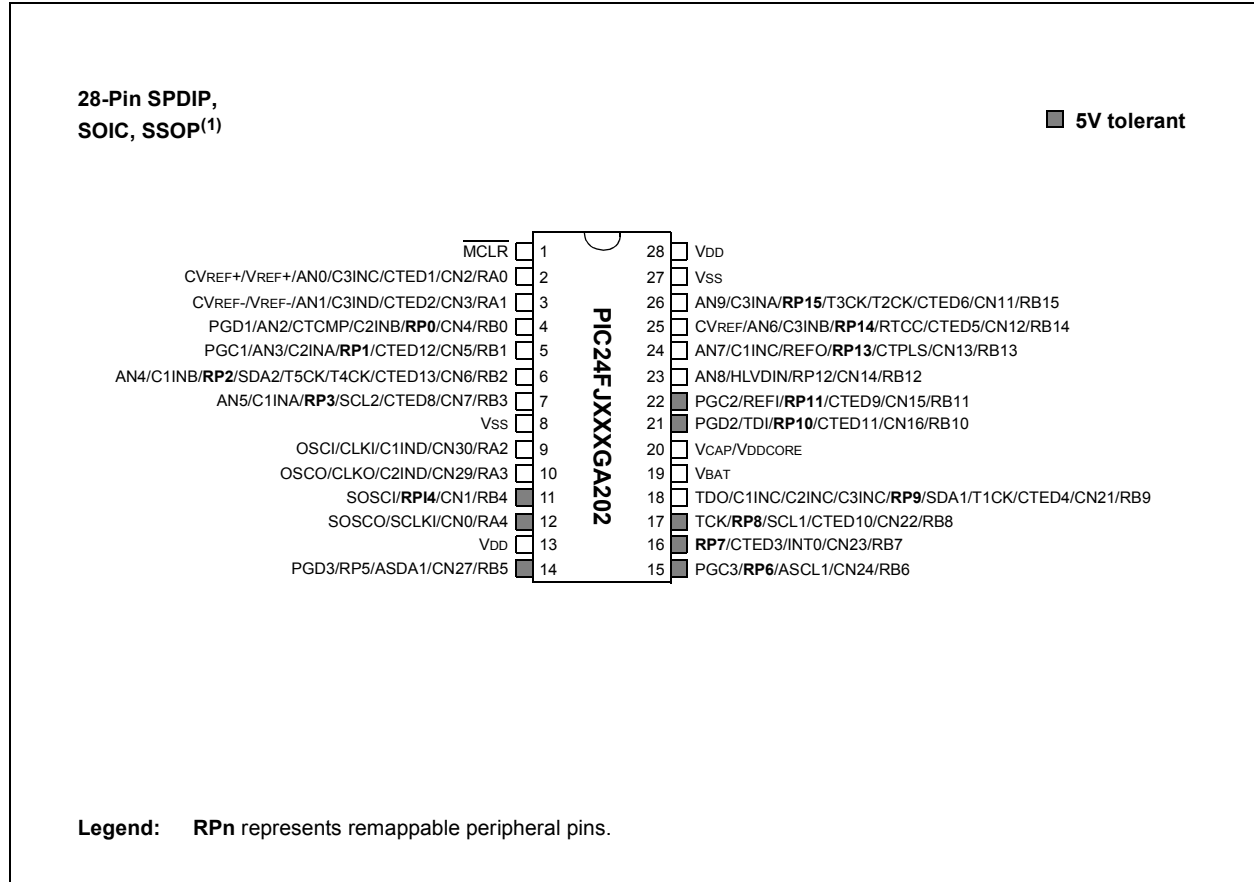

PIC24FJ128GA204 FAMILY

Pin Diagrams (Continued)

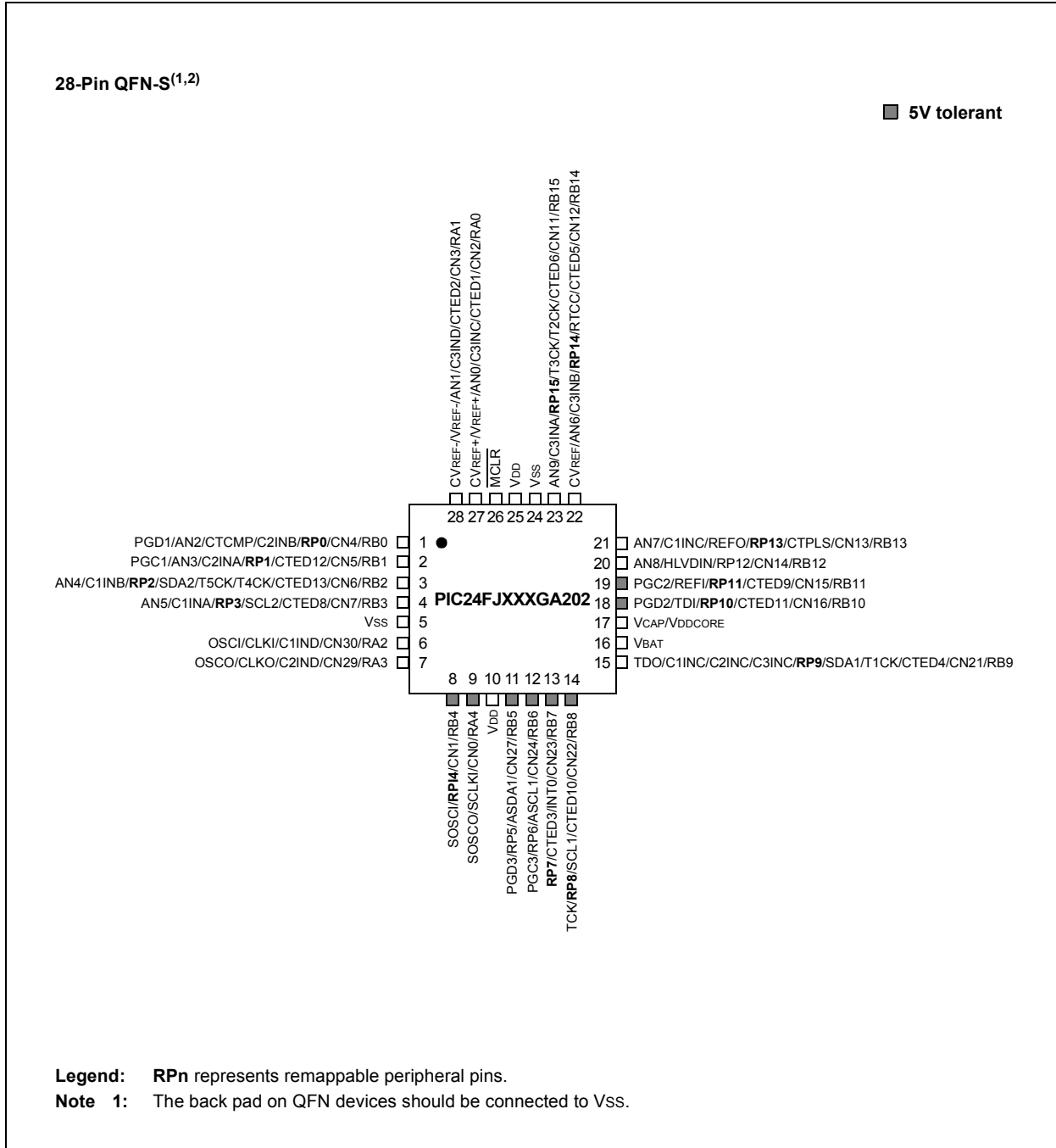

PIC24FJ128GA204 FAMILY

Pin Diagrams (Continued)

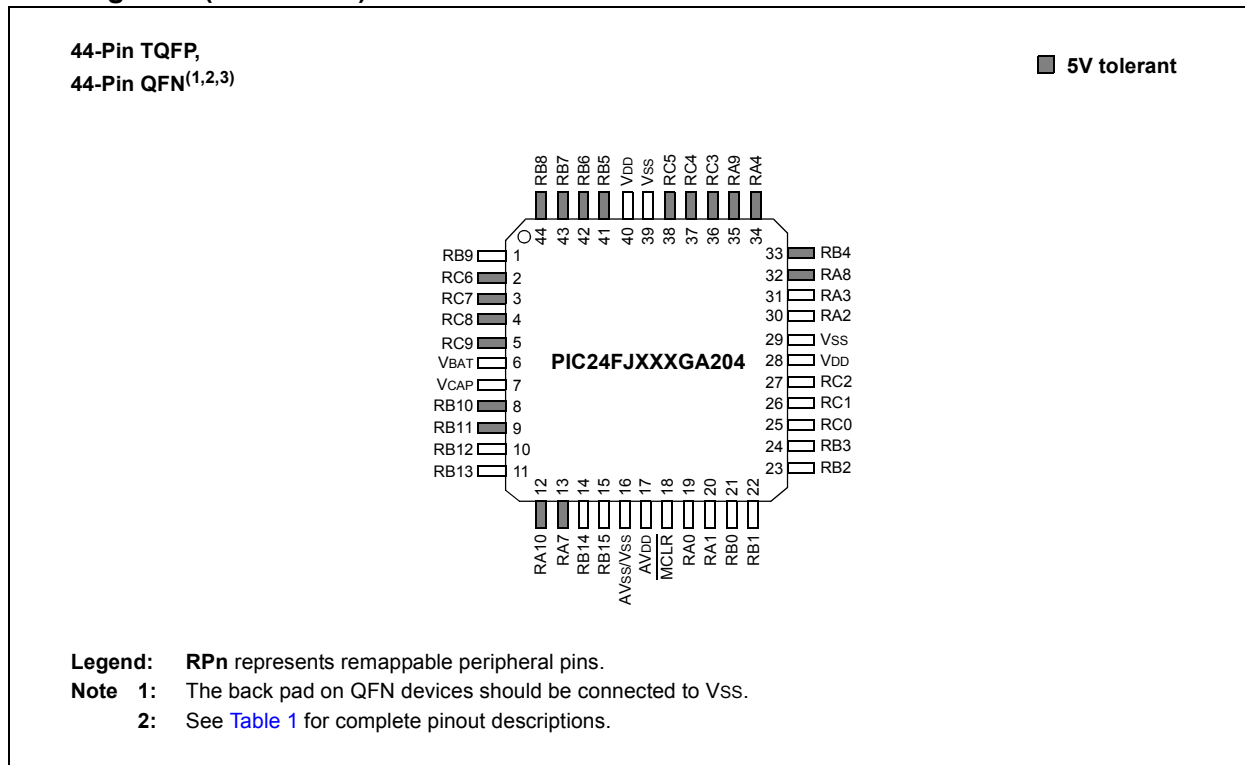

TABLE 1: PIC24FJXXGA204 PIN FUNCTION DESCRIPTIONS

Pin	Function	Pin	Function
1	C1INC/C2INC/C3INC/ RP9 /SDA1/T1CK/CTED4/PMD3/CN21/RB9	23	AN4/C1INB/ RP2 /SDA2/T5CK/T4CK/CTED13/CN6/RB2
2	RP22 /PMA1/PMALH/CN18/RC6	24	AN5/C1INA/ RP3 /SCL2/CTED8/CN7/RB3
3	RP23 /PMA0/PMALL/CN17/RC7	25	AN10/ RP16 /PMBE1/CN8/RC0
4	RP24 /PMA5/CN20/RC8	26	AN11/ RP17 /PMCS2/CN9/RC1
5	RP25 /CTED7/PMA6/CN19/RC9	27	AN12/ RP18 /PMACK1/CN10/RC2
6	VBAT	28	VDD
7	VCAP	29	VSS
8	RP10 /CTED11/PMD2/CN16/PGD2/RB10	30	OSCI/CLKI/C1IND/PMCS1/CN30/RA2
9	REFI/ RP11 /CTED9/PMD1/CN15/PGC2/RB11	31	OSCO/CLKO/C2IND/CN29/RA3
10	AN8/HLVDIN/ RP12 /PMD0/CN14/ RB12	32	TDO/PMA8/CN34/RA8
11	AN7/C1INC/REFO/ RP13 /CTPLS/PMRD/PMWR/CN13/RB13	33	SOSCI/CN1/ RP14 /RB4
12	TMS/PMA2/PMALU/CN36/RA10	34	SOSCO/SCLKI/CN0/RA4
13	TCK/PMA7/CN33/RA7	35	TDI/PMA9/CN35/RA9
14	CVREF+/VREF+/AN0/C3INC/CTED1/CN2/RA0	36	RP19 /PMBE0/CN28/RC3
15	AN9/C3INA/ RP15 /T3CK/T2CK/CTED6/PMA14/CN11/PMCS/PMCS1/RB15	37	RP20 /PMA4/CN25/RC4
16	AVSS/VSS	38	RP21 /PMA3/CN26/RC5
17	AVDD	39	VSS
18	MCLR	40	VDD
19	CVREF-/VREF-/AN1/C3IND/CTED2/CN3/RA1	41	PGD3/ RP5 /ASDA1 ⁽¹⁾ /PMD7/CN27/RB5
20	AN2/CTCMP/C2INB/ RP0 /CN4/PGD1/RB0	42	PGC3/ RP6 /ASCL1 ⁽¹⁾ /PMD6/CN24/RB6
21	AN3/C2INA/ RP1 /CTED12/CN5/PGC1/RB1	43	RP7 /CTED3/INT0/CN23/PMD5/RB7
22		44	RP8 /SCL1/CTED10/PMD4/CN22/RB8

Legend: RPN represents remappable peripheral pins.

Note 1: Alternative multiplexing for SDA1 and SCL1 when the I2C1SEL bit is set.

PIC24FJ128GA204 FAMILY

Table of Contents

1.0	Device Overview	9
2.0	Guidelines for Getting Started with 16-Bit Microcontrollers	21
3.0	CPU	27
4.0	Memory Organization	33
5.0	Direct Memory Access Controller (DMA)	67
6.0	Flash Program Memory	75
7.0	Resets	81
8.0	Interrupt Controller	87
9.0	Oscillator Configuration	141
10.0	Power-Saving Features	155
11.0	I/O Ports	167
12.0	Timer1	195
13.0	Timer2/3 and Timer4/5	199
14.0	Input Capture with Dedicated Timers	205
15.0	Output Compare with Dedicated Timers	211
16.0	Serial Peripheral Interface (SPI)	221
17.0	Inter-Integrated Circuit™ (I ² C™)	237
18.0	Universal Asynchronous Receiver Transmitter (UART)	245
19.0	Data Signal Modulator (DSM)	257
20.0	Enhanced Parallel Master Port (EPMP)	263
21.0	Real-Time Clock and Calendar (RTCC)	275
22.0	Cryptographic Engine	289
23.0	32-Bit Programmable Cyclic Redundancy Check (CRC) Generator	305
24.0	12-Bit A/D Converter with Threshold Detect	311
25.0	Triple Comparator Module	331
26.0	Comparator Voltage Reference	337
27.0	Charge Time Measurement Unit (CTMU)	339
28.0	High/Low-Voltage Detect (HLVD)	347
29.0	Special Features	349
30.0	Development Support	363
31.0	Instruction Set Summary	367
32.0	Electrical Characteristics	375
33.0	Packaging Information	407
	Appendix A: Revision History	425
	Index	427
	The Microchip Web Site	433
	Customer Change Notification Service	433
	Customer Support	433
	Product Identification System	435

PIC24FJ128GA204 FAMILY

TO OUR VALUED CUSTOMERS

It is our intention to provide our valued customers with the best documentation possible to ensure successful use of your Microchip products. To this end, we will continue to improve our publications to better suit your needs. Our publications will be refined and enhanced as new volumes and updates are introduced.

If you have any questions or comments regarding this publication, please contact the Marketing Communications Department via E-mail at docerrors@microchip.com. We welcome your feedback.

Most Current Data Sheet

To obtain the most up-to-date version of this data sheet, please register at our Worldwide Web site at:

<http://www.microchip.com>

You can determine the version of a data sheet by examining its literature number found on the bottom outside corner of any page. The last character of the literature number is the version number, (e.g., DS30000000A is version A of document DS30000000).

Errata

An errata sheet, describing minor operational differences from the data sheet and recommended workarounds, may exist for current devices. As device/documentation issues become known to us, we will publish an errata sheet. The errata will specify the revision of silicon and revision of document to which it applies.

To determine if an errata sheet exists for a particular device, please check with one of the following:

- Microchip's Worldwide Web site; <http://www.microchip.com>
- Your local Microchip sales office (see last page)

When contacting a sales office, please specify which device, revision of silicon and data sheet (include literature number) you are using.

Customer Notification System

Register on our web site at www.microchip.com to receive the most current information on all of our products.

PIC24FJ128GA204 FAMILY

NOTES:

PIC24FJ128GA204 FAMILY

1.0 DEVICE OVERVIEW

This document contains device-specific information for the following devices:

- PIC24FJ64GA202
- PIC24FJ128GA202
- PIC24FJ64GA204
- PIC24FJ128GA204

The PIC24FJ128GA204 family expands the capabilities of the PIC24F family by adding a complete selection of Cryptographic Engines, ISO 7816 support and I²S support to its existing features. This combination, along with its ultra low-power features and Direct Memory Access (DMA) for peripherals, make this family the new standard for mixed-signal PIC[®] microcontrollers in one economical and power-saving package.

1.1 Core Features

1.1.1 16-BIT ARCHITECTURE

Central to all PIC24F devices is the 16-bit modified Harvard architecture, first introduced with Microchip's dsPIC[®] Digital Signal Controllers (DSCs). The PIC24F CPU core offers a wide range of enhancements, such as:

- 16-bit data and 24-bit address paths with the ability to move information between data and memory spaces
- Linear addressing of up to 12 Mbytes (program space) and 32 Kbytes (data)
- A 16-element Working register array with built-in software stack support
- A 17 x 17 hardware multiplier with support for integer math
- Hardware support for 32 by 16-bit division
- An instruction set that supports multiple addressing modes and is optimized for high-level languages, such as 'C'
- Operational performance up to 16 MIPS

1.1.2 XLP POWER-SAVING TECHNOLOGY

The PIC24FJ128GA204 family of devices introduces a greatly expanded range of power-saving operating modes for the ultimate in power conservation. The new modes include:

- Retention Sleep, with essential circuits being powered from a separate low-voltage regulator
- Deep Sleep without RTCC, for the lowest possible power consumption under software control
- VBAT mode (with or without RTCC), to continue limited operation from a backup battery when V_{DD} is removed

Many of these new low-power modes also support the continuous operation of the low-power, on-chip Real-Time Clock/Calendar (RTCC), making it possible for an application to keep time while the device is otherwise asleep.

Aside from these new features, PIC24FJ128GA204 family devices also include all of the legacy power-saving features of previous PIC24F microcontrollers, such as:

- On-the-Fly Clock Switching, allowing the selection of a lower power clock during run time
- Doze Mode Operation, for maintaining peripheral clock speed while slowing the CPU clock
- Instruction-Based Power-Saving Modes, for quick invocation of Idle and the many Sleep modes

1.1.3 OSCILLATOR OPTIONS AND FEATURES

All of the devices in the PIC24FJ128GA204 family offer five different oscillator options, allowing users a range of choices in developing application hardware. These include:

- Two Crystal modes
- Two External Clock modes
- A Phase-Locked Loop (PLL) frequency multiplier, which allows clock speeds of up to 32 MHz
- A Fast Internal Oscillator (FRC) – nominal 8 MHz output with multiple frequency divider options and automatic frequency self-calibration during run time
- A separate, Low-Power Internal RC Oscillator (LPRC) – 31 kHz nominal, for low-power, timing-insensitive applications.

The internal oscillator block also provides a stable reference source for the Fail-Safe Clock Monitor (FSCM). This option constantly monitors the main clock source against a reference signal provided by the internal oscillator and enables the controller to switch to the internal oscillator, allowing for continued low-speed operation or a safe application shutdown.

1.1.4 EASY MIGRATION

Regardless of the memory size, all devices share the same rich set of peripherals, allowing for a smooth migration path as applications grow and evolve. This extends the ability of applications to grow from the relatively simple, to the powerful and complex, yet still selecting a Microchip device.

PIC24FJ128GA204 FAMILY

1.2 DMA Controller

PIC24FJ128GA204 family devices also add a Direct Memory Access (DMA) Controller to the existing PIC24F architecture. The DMA acts in concert with the CPU, allowing data to move between data memory and peripherals without the intervention of the CPU, increasing data throughput and decreasing execution time overhead. Six independently programmable channels make it possible to service multiple peripherals at virtually the same time, with each channel peripheral performing a different operation. Many types of data transfer operations are supported.

1.3 Cryptographic Engine

The Cryptographic Engine provides a new set of data security options. Using its own free-standing state machines, the engine can independently perform NIST standard encryption and decryption of data, independently of the CPU.

Support for True Random Number Generation (TRNG) and Pseudorandom Number Generation (PRNG); NIST SP800-90 compliant.

1.4 Other Special Features

- **Peripheral Pin Select (PPS):** The Peripheral Pin Select feature allows most digital peripherals to be mapped over a fixed set of digital I/O pins. Users may independently map the input and/or output of any one of the many digital peripherals to any one of the I/O pins.
- **Communications:** The PIC24FJ128GA204 family incorporates a range of serial communication peripherals to handle a range of application requirements. There are two independent I²C™ modules that support both Master and Slave modes of operation. Devices also have, through the PPS feature, four independent UARTs with built-in IrDA® encoders/decoders, ISO 7816 Smart Card support (UART1 and UART2 only), and three SPI modules with I²S and variable data width support.
- **Analog Features:** All members of the PIC24FJ128GA204 family include a 12-bit A/D Converter module and a triple comparator module. The A/D module incorporates a range of new features that allows the converter to assess and make decisions on incoming data, reducing CPU overhead for routine A/D conversions. The comparator module includes three analog comparators that are configurable for a wide range of operations.
- **CTMU Interface:** In addition to their other analog features, members of the PIC24FJ128GA204 family include the CTMU interface module. This provides a convenient method for precision time measurement and pulse generation, and can serve as an interface for capacitive sensors.

- **Enhanced Parallel Master/Parallel Slave Port:**

This module allows rapid and transparent access to the microcontroller data bus, and enables the CPU to directly address external data memory. The parallel port can function in Master or Slave mode, accommodating data widths of 4, 8 or 16 bits, and address widths of up to 23 bits in Master modes.

- **Real-Time Clock and Calendar (RTCC):** This module implements a full-featured clock and calendar with alarm functions in hardware, freeing up timer resources and program memory space for use of the core application.

- **Data Signal Modulator (DSM):** The Data Signal Modulator (DSM) allows the user to mix a digital data stream (the “modulator signal”) with a carrier signal to produce a modulated output.

1.5 Details on Individual Family Members

Devices in the PIC24FJ128GA204 family are available in 28-pin and 44-pin packages. The general block diagram for all devices is shown in [Figure 1-1](#).

The devices are differentiated from each other in six ways:

1. Flash program memory (64 Kbytes for PIC24FJ64GA2XX devices and 128 Kbytes for PIC24FJ128GA2XX devices).
2. Available I/O pins and ports (21 pins on two ports for 28-pin devices, 35 pins on three ports for 44-pin devices).
3. Available Input Change Notification (ICN) inputs (20 on 28-pin devices and 34 on 44-pin devices).
4. Available remappable pins (14 pins on 28-pin devices and 24 pins on 44-pin devices).
5. Analog input channels for the A/D Converter (12 channels for 44-pin devices and 9 channels for 28-pin devices).

All other features for devices in this family are identical. These are summarized in [Table 1-1](#) and [Table 1-2](#).

A list of the pin features available on the PIC24FJ128GA204 family devices, sorted by function, is shown in [Table 1-3](#). Note that this table shows the pin location of individual peripheral features and not how they are multiplexed on the same pin. This information is provided in the pinout diagrams in the beginning of the data sheet. Multiplexed features are sorted by the priority given to a feature, with the highest priority peripheral being listed first.

PIC24FJ128GA204 FAMILY

TABLE 1-1: DEVICE FEATURES FOR THE PIC24FJ128GA204 FAMILY: 44-PIN DEVICES

Features	PIC24FJ64GA204	PIC24FJ128GA204
Operating Frequency	DC – 32 MHz	
Program Memory (bytes)	64K	128K
Program Memory (instructions)	22,016	44,032
Data Memory (bytes)	8K	
Interrupt Sources (soft vectors/ NMI traps)	71 (67/4)	
I/O Ports	Ports A, B, C	
Total I/O Pins	35	
Remappable Pins	25 (24 I/Os, 1 Input only)	
Timers:		
Total Number (16-bit)	5 ⁽¹⁾	
32-Bit (from paired 16-bit timers)	2	
Input Capture w/Timer Channels	6 ⁽¹⁾	
Output Compare/PWM Channels	6 ⁽¹⁾	
Input Change Notification Interrupt	35	
Serial Communications:		
UART	4 ⁽¹⁾	
SPI (3-wire/4-wire)	3 ⁽¹⁾	
I ² C™	2	
Digital Signal Modulator (DSM)	Yes	
Parallel Communications (EPMP/PSP)	Yes	
JTAG Boundary Scan	Yes	
12-Bit SAR Analog-to-Digital Converter (A/D) (input channels)	13	
Analog Comparators	3	
CTMU Interface	13 Channels	
Resets (and Delays)	Core POR, VDD POR, VBAT POR, BOR, RESET Instruction, MCLR, WDT, Illegal Opcode, REPEAT Instruction, Hardware Traps, Configuration Word Mismatch (OST, PLL Lock)	
Instruction Set	76 Base Instructions, Multiple Addressing Mode Variations	
Packages	44-Pin TQFP and QFN	
Cryptographic Engine	Supports AES with 128, 192 and 256-Bit Key, DES and TDES, True Random and Pseudorandom Number Generator, On-Chip OTP Storage	
RTCC	Yes	

Note 1: Peripherals are accessible through remappable pins.

PIC24FJ128GA204 FAMILY

TABLE 1-2: DEVICE FEATURES FOR THE PIC24FJ128GA204 FAMILY: 28-PIN DEVICES

Features	PIC24FJ64GA202	PIC24FJ128GA202
Operating Frequency	DC – 32 MHz	
Program Memory (bytes)	64K	128K
Program Memory (instructions)	22,016	44,032
Data Memory (bytes)	8K	
Interrupt Sources (soft vectors/ NMI traps)	71 (67/4)	
I/O Ports	Ports A, B	
Total I/O Pins	21	
Remappable Pins	16 (15 I/Os, 1 Input only)	
Timers:		
Total Number (16-bit)	5 ⁽¹⁾	
32-Bit (from paired 16-bit timers)	2	
Input Capture w/Timer Channels	6 ⁽¹⁾	
Output Compare/PWM Channels	6 ⁽¹⁾	
Input Change Notification Interrupt	21	
Serial Communications:		
UART	4 ⁽¹⁾	
SPI (3-wire/4-wire)	3 ⁽¹⁾	
I ² C™	2	
Digital Signal Modulator (DSM)	Yes	
JTAG Boundary Scan	Yes	
12-Bit SAR Analog-to-Digital Converter (A/D) (input channels)	10	
Analog Comparators	3	
CTMU Interface	10 Channels	
Resets (and Delays)	Core POR, VDD POR, VBAT POR, BOR, RESET Instruction, MCLR, WDT, Illegal Opcode, REPEAT Instruction, Hardware Traps, Configuration Word Mismatch (OST, PLL Lock)	
Instruction Set	76 Base Instructions, Multiple Addressing Mode Variations	
Packages	28-Pin SPDIP, SSOP, SOIC and QFN-S	
Cryptographic Engine	Supports AES with 128, 192 and 256-Bit Key, DES and TDES, True Random and Pseudorandom Number Generator, On-Chip OTP Storage	
RTCC	Yes	

Note 1: Peripherals are accessible through remappable pins.

PIC24FJ128GA204 FAMILY

FIGURE 1-1: PIC24FJ128GA204 FAMILY GENERAL BLOCK DIAGRAM

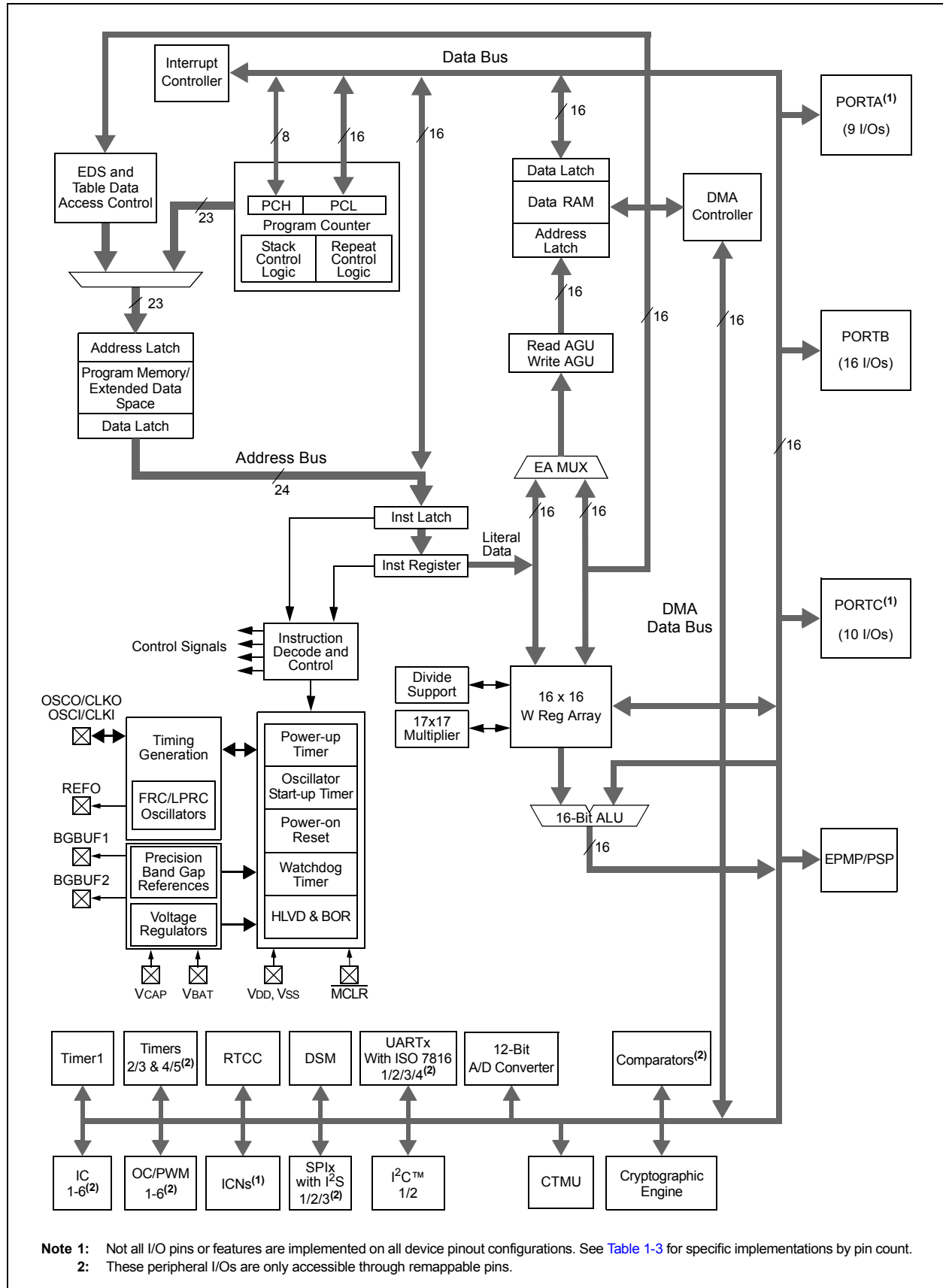

PIC24FJ128GA204 FAMILY

TABLE 1-3: PIC24FJ128GA204 FAMILY PINOUT DESCRIPTIONS

Pin Function	Pin Number/Grid Locator			I/O	Input Buffer	Description
	28-Pin SPDIP/SOIC/SSOP	28-Pin QFN-S	44-Pin TQFP/QFN			
AN0	2	27	19	I	ANA	12-Bit SAR A/D Converter Inputs.
AN1	3	28	20	I	ANA	
AN2	4	1	21	I	ANA	
AN3	5	2	22	I	ANA	
AN4	6	3	23	I	ANA	
AN5	7	4	24	I	ANA	
AN6	25	22	14	I	ANA	
AN7	24	21	11	I	ANA	
AN8	23	20	10	I	ANA	
AN9	26	23	15	I	ANA	
AN10	—	—	25	I	ANA	
AN11	—	—	26	I	ANA	
AN12	—	—	27	I	ANA	
ASCL1	15	12	42	—	—	
ASDA1	2	27	19	—	—	
AVDD	—	—	17	P	ANA	Positive Supply for Analog modules.
AVSS	—	24	16	P	ANA	Ground Reference for Analog modules.
C1INA	7	4	24	I	ANA	Comparator 1 Input A.
C1INB	6	3	23	I	ANA	Comparator 1 Input B.
C1INC	24	15	1	I	ANA	Comparator 1 Input C.
C1IND	9	6	30	I	ANA	Comparator 1 Input D.
C2INA	5	2	22	I	ANA	Comparator 2 Input A.
C2INB	4	1	21	I	ANA	Comparator 2 Input B.
C2INC	18	15	1	I	ANA	Comparator 2 Input C.
C2IND	10	7	31	I	ANA	Comparator 2 Input D.
C3INA	26	23	15	I	ANA	Comparator 3 Input A.
C3INB	25	22	14	I	ANA	Comparator 3 Input B.
C3INC	2	15	1	I	ANA	Comparator 3 Input C.
C3IND	3	28	20	I	ANA	Comparator 3 Input D.
CLKI	9	6	30	I	ANA	Main Clock Input Connection.
CLKO	10	7	31	O	—	System Clock Output.

Legend: ST = Schmitt Trigger input TTL = TTL compatible input I = Input
ANA = Analog input O = Output P = Power
I²C = ST with I²C™ or SMBus levels

PIC24FJ128GA204 FAMILY

TABLE 1-3: PIC24FJ128GA204 FAMILY PINOUT DESCRIPTIONS (CONTINUED)

Pin Function	Pin Number/Grid Locator			I/O	Input Buffer	Description
	28-Pin SPDIP/SOIC/SSOP	28-Pin QFN-S	44-Pin TQFP/QFN			
CN0	12	9	34	—	—	Interrupt-on-Change Inputs.
CN1	11	8	33	—	—	
CN2	2	27	19	—	—	
CN3	3	28	20	—	—	
CN4	4	1	21	—	—	
CN5	5	2	22	—	—	
CN6	6	3	23	—	—	
CN7	7	4	24	—	—	
CN8	—	—	25	—	—	
CN9	—	—	26	—	—	
CN10	—	—	27	—	—	
CN11	26	23	15	—	—	
CN12	25	22	14	—	—	
CN13	24	21	11	—	—	
CN14	23	20	10	—	—	
CN15	22	19	9	—	—	
CN16	21	18	8	—	—	
CN17	—	—	3	—	—	
CN18	—	—	2	—	—	
CN19	—	—	5	—	—	
CN20	—	—	4	—	—	
CN21	18	15	1	—	—	
CN22	17	14	44	—	—	
CN23	16	13	43	—	—	
CN24	15	12	42	—	—	
CN25	—	—	37	—	—	
CN26	—	—	38	—	—	
CN27	14	11	41	—	—	
CN28	—	—	36	—	—	
CN29	10	7	31	—	—	
CN30	9	6	30	—	—	
CN33	—	—	13	—	—	
CN34	—	—	32	—	—	
CN35	—	—	35	—	—	
CN36	—	—	12	—	—	
CTCMP	4	1	21	I	ANA	

Legend: ST = Schmitt Trigger input

ANA = Analog input

I²C = ST with I²C™ or SMBus levels

TTL = TTL compatible input

O = Output

I = Input

P = Power

PIC24FJ128GA204 FAMILY

TABLE 1-3: PIC24FJ128GA204 FAMILY PINOUT DESCRIPTIONS (CONTINUED)

Pin Function	Pin Number/Grid Locator			I/O	Input Buffer	Description
	28-Pin SPDIP/SOIC/SSOP	28-Pin QFN-S	44-Pin TQFP/QFN			
CTED1	2	27	19	I	ANA	CTMU External Edge Inputs.
CTED2	3	28	20	I	ANA	
CTED3	16	13	43	I	ANA	
CTED4	18	15	1	I	ANA	
CTED5	25	22	14	I	ANA	
CTED6	26	23	15	I	ANA	
CTED7	—	—	5	I	ANA	
CTED8	7	4	24	I	ANA	
CTED9	22	19	9	I	ANA	
CTED10	17	14	44	I	ANA	
CTED11	21	18	8	I	ANA	
CTED12	5	2	22	I	ANA	
CTED13	6	3	23	I	ANA	
CTPLS	24	21	11	O	—	CTMU Pulse Output.
CVREF	25	22	14	O	ANA	Comparator Voltage Reference Output.
CVREF+	2	27	19	I	ANA	Comparator Reference Voltage (high) Input.
CVREF-	3	28	20	I	ANA	Comparator Reference Voltage (low) Input.
INT0	16	13	43	I	ST	External Interrupt Input 0.
HLVDIN	23	20	10	I	ANA	High/Low-Voltage Detect Input.
MCLR	1	26	18	I	ST	Master Clear (device Reset) Input. This line is brought low to cause a Reset.
OSCI	9	6	30	I	ANA	Main Oscillator Input Connection.
OSCO	10	7	31	O	—	Main Oscillator Output Connection.
PGC1	5	2	22	I/O	ST	In-Circuit Debugger/Emulator/ICSP™ Programming Clock.
PGC2	22	19	9	I/O	ST	
PGC3	15	12	42	I/O	ST	
PGD1	4	1	21	I/O	ST	
PGD2	21	18	8	I/O	ST	
PGD3	14	11	41	I/O	ST	

Legend: ST = Schmitt Trigger input TTL = TTL compatible input I = Input
ANA = Analog input O = Output P = Power
I²C = ST with I²C™ or SMBus levels

PIC24FJ128GA204 FAMILY

TABLE 1-3: PIC24FJ128GA204 FAMILY PINOUT DESCRIPTIONS (CONTINUED)

Pin Function	Pin Number/Grid Locator			I/O	Input Buffer	Description
	28-Pin SPDIP/SOIC/SSOP	28-Pin QFN-S	44-Pin TQFP/QFN			
PMA0/PMALL	—	—	3	O	—	Parallel Master Port Address.
PMA1/PMALH	—	—	2	O	—	
PMA14/PMCS/PMCS1	—	—	15	O	—	
PMA2/PMALU	—	—	12	O	—	
PMA3	—	—	38	O	—	
PMA4	—	—	37	O	—	
PMA5	—	—	4	O	—	
PMA6	—	—	5	O	—	
PMA7	—	—	13	O	—	
PMA8	—	—	32	O	—	
PMA9	—	—	35	O	—	
PMACK1	—	—	27	I	ST/TTL	Parallel Master Port Acknowledge Input 1.
PMBE0	—	—	36	O	—	Parallel Master Port Byte Enable 0 Strobe.
PMBE1	—	—	25	O	—	Parallel Master Port Byte Enable 1 Strobe.
PMCS1	—	—	30	I/O	ST/TTL	Parallel Master Port Chip Select 1 Strobe.
PMD0	—	—	10	I/O	ST/TTL	Parallel Master Port Data (Demultiplexed Master mode) or Address/Data (Multiplexed Master modes).
PMD1	—	—	9	I/O	ST/TTL	
PMD2	—	—	8	I/O	ST/TTL	
PMD3	—	—	1	I/O	ST/TTL	
PMD4	—	—	44	I/O	ST/TTL	
PMD5	—	—	43	I/O	ST/TTL	
PMD6	—	—	42	I/O	ST/TTL	
PMD7	—	—	41	I/O	ST/TTL	
PMRD	—	—	11	O	—	Parallel Master Port Read Strobe.
PMWR	—	—	14	O	—	Parallel Master Port Write Strobe.
RA0	2	27	19	I/O	ST	PORTA Digital I/Os.
RA1	3	28	20	I/O	ST	
RA2	9	6	30	I/O	ST	
RA3	10	7	31	I/O	ST	
RA4	12	9	34	I	ST	
RA7	—	—	13	I/O	ST	
RA8	—	—	32	I/O	ST	
RA9	—	—	35	I/O	ST	
RA10	—	—	12	I/O	ST	

Legend: ST = Schmitt Trigger input
ANA = Analog input
I²C = ST with I²C™ or SMBus levels

TTL = TTL compatible input
O = Output

I = Input
P = Power

PIC24FJ128GA204 FAMILY

TABLE 1-3: PIC24FJ128GA204 FAMILY PINOUT DESCRIPTIONS (CONTINUED)

Pin Function	Pin Number/Grid Locator			I/O	Input Buffer	Description
	28-Pin SPDIP/SOIC/SSOP	28-Pin QFN-S	44-Pin TQFP/QFN			
RB0	4	1	21	I/O	ST	PORTB Digital I/Os.
RB1	5	2	22	I/O	ST	
RB2	6	3	23	I/O	ST	
RB3	7	4	24	I/O	ST	
RB4	11	8	33	I	ST	
RB5	14	11	41	I/O	ST	
RB6	15	12	42	I/O	ST	
RB7	16	13	43	I/O	ST	
RB8	17	14	44	I/O	ST	
RB9	18	15	1	I/O	ST	
RB10	21	18	8	I/O	ST	
RB11	22	19	9	I/O	ST	
RB12	23	20	10	I/O	ST	
RB13	24	21	11	I/O	ST	
RB14	25	22	14	I/O	ST	
RB15	26	23	15	I/O	ST	
RC0	—	—	25	I/O	ST	PORTC Digital I/Os.
RC1	—	—	26	I/O	ST	
RC2	—	—	27	I/O	ST	
RC3	—	—	36	I/O	ST	
RC4	—	—	37	I/O	ST	
RC5	—	—	38	I/O	ST	
RC6	—	—	2	I/O	ST	
RC7	—	—	3	I/O	ST	
RC8	—	—	4	I/O	ST	
RC9	—	—	5	I/O	ST	
REFI	22	19	9	—	—	Reference Clock Output.
REFO	24	21	11	—	—	

Legend: ST = Schmitt Trigger input TTL = TTL compatible input I = Input
ANA = Analog input O = Output P = Power
I²C = ST with I²C™ or SMBus levels

PIC24FJ128GA204 FAMILY

TABLE 1-3: PIC24FJ128GA204 FAMILY PINOUT DESCRIPTIONS (CONTINUED)

Pin Function	Pin Number/Grid Locator			I/O	Input Buffer	Description
	28-Pin SPDIP/SOIC/SSOP	28-Pin QFN-S	44-Pin TQFP/QFN			
RP0	4	1	21	I/O	ST	Remappable Peripherals (input or output).
RP1	5	2	22	I/O	ST	
RP2	6	3	23	I/O	ST	
RP3	7	4	24	I/O	ST	
RP5	14	11	41	I/O	ST	
RP6	3,15	12	42	I/O	ST	
RP7	16	13	43	I/O	ST	
RP8	17	14	44	I/O	ST	
RP9	18	15	1	I/O	ST	
RP10	21	18	8	I/O	ST	
RP11	22	19	9	I/O	ST	
RP12	23	20	10	I/O	ST	
RP13	24	21	11	I/O	ST	
RP14	25	22	14	I/O	ST	
RP15	26	23	15	I/O	ST	
RP16	—	—	25	I/O	ST	
RP17	—	—	26	I/O	ST	
RP18	—	—	27	I/O	ST	
RP19	—	—	36	I/O	ST	
RP20	—	—	37	I/O	ST	
RP21	—	—	38	I/O	ST	
RP22	—	—	2	I/O	ST	
RP23	—	—	3	I/O	ST	
RP24	—	—	4	I/O	ST	
RP25	—	—	5	I/O	ST	
RPI4	11	8	33	I	ST	Remappable Peripheral (input).
RTCC	25	22	14	O	—	Real-Time Clock Alarm/Seconds Pulse Output.
SCL1	17	14	44	I/O	I ² C	I2C1 Synchronous Serial Clock Input/Output.
SCL2	7	4	24	I/O	I ² C	I2C2 Synchronous Serial Clock Input/Output.
SCLKI	12	9	34	I	—	Secondary Oscillator Digital Clock Input.
SDA1	18	15	1	I/O	I ² C	I2C1 Data Input/Output.
SDA2	6	3	23	I/O	I ² C	I2C2 Data Input/Output.
SOSCI	11	8	33	I	ANA	Secondary Oscillator/Timer1 Clock Input.
SOSCO	12	9	34	O	ANA	Secondary Oscillator/Timer1 Clock Output.

Legend: ST = Schmitt Trigger input
ANA = Analog input
I²C = ST with I²C™ or SMBus levels

TTL = TTL compatible input
O = Output

I = Input
P = Power

PIC24FJ128GA204 FAMILY

TABLE 1-3: PIC24FJ128GA204 FAMILY PINOUT DESCRIPTIONS (CONTINUED)

Pin Function	Pin Number/Grid Locator			I/O	Input Buffer	Description
	28-Pin SPDIP/SOIC/SSOP	28-Pin QFN-S	44-Pin TQFP/QFN			
T1CK	18	15	1	I	ST	Timer1 Clock.
T2CK	26	23	15	I	ST	Timer2 Clock.
T3CK	26	23	15	I	ST	Timer3 Clock.
T4CK	6	3	23	I	ST	Timer4 Clock.
T5CK	6	3	23	I	ST	Timer5 Clock.
TCK	17	14	13	I	ST	JTAG Test Clock/Programming Clock Input.
TDI	21	18	35	I	ST	JTAG Test Data/Programming Data Input.
TDO	18	15	32	O	—	JTAG Test Data Output.
TMS	22	19	12	I	—	JTAG Test Mode Select Input.
VBAT	19	16	6	P	—	Backup Battery (B+) Input (1.2V nominal).
VCAP	20	17	7	P	—	External Filter Capacitor Connection.
VDD	13,28	25,10	28,40	P	—	Positive Supply for Peripheral Digital Logic and I/O Pins.
VDDCORE	20	17	7	—	—	Microcontroller Core Supply Voltage.
VREF+	2	27	19	I	ANA	A/D Reference Voltage Input (+).
VREF-	3	28	20	I	ANA	A/D Reference Voltage Input (-).
VSS	8,27	5,24	29,39	P	—	Ground Reference for Logic and I/O Pins.

Legend: ST = Schmitt Trigger input TTL = TTL compatible input I = Input
ANA = Analog input O = Output P = Power
I²C = ST with I²C™ or SMBus levels

PIC24FJ128GA204 FAMILY

2.0 GUIDELINES FOR GETTING STARTED WITH 16-BIT MICROCONTROLLERS

2.1 Basic Connection Requirements

Getting started with the PIC24FJ128GA204 family of 16-bit microcontrollers requires attention to a minimal set of device pin connections before proceeding with development.

The following pins must always be connected:

- All VDD and VSS pins (see [Section 2.2 “Power Supply Pins”](#))
- All AVDD and AVSS pins, regardless of whether or not the analog device features are used (see [Section 2.2 “Power Supply Pins”](#))
- MCLR pin (see [Section 2.3 “Master Clear \(MCLR\) Pin”](#))
- ENVREG/DISVREG and VCAP/VDDCORE pins (see [Section 2.4 “Voltage Regulator Pins \(ENVREG/DISVREG and VCAP/VDDCORE\)”](#))

These pins must also be connected if they are being used in the end application:

- PGECx/PGEDx pins used for In-Circuit Serial Programming™ (ICSP™) and debugging purposes (see [Section 2.5 “ICSP Pins”](#))
- OSCI and OSCO pins when an external oscillator source is used (see [Section 2.6 “External Oscillator Pins”](#))

Additionally, the following pins may be required:

- VREF+/VREF- pins used when external voltage reference for analog modules is implemented

Note: The AVDD and AVSS pins must always be connected, regardless of whether any of the analog modules are being used.

The minimum mandatory connections are shown in [Figure 2-1](#).

FIGURE 2-1: RECOMMENDED MINIMUM CONNECTIONS

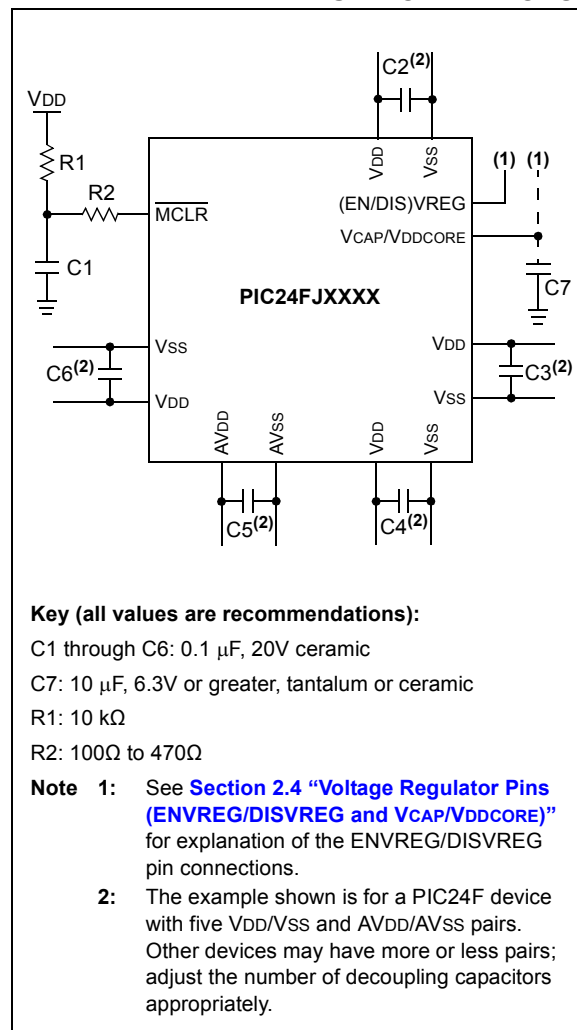

PIC24FJ128GA204 FAMILY

2.2 Power Supply Pins

2.2.1 DECOUPLING CAPACITORS

The use of decoupling capacitors on every pair of power supply pins, such as VDD, VSS, AVDD and AVSS, is required.

Consider the following criteria when using decoupling capacitors:

- **Value and type of capacitor:** A 0.1 μF (100 nF), 10-20V capacitor is recommended. The capacitor should be a low-ESR device with a resonance frequency in the range of 200 MHz and higher. Ceramic capacitors are recommended.
- **Placement on the printed circuit board:** The decoupling capacitors should be placed as close to the pins as possible. It is recommended to place the capacitors on the same side of the board as the device. If space is constricted, the capacitor can be placed on another layer on the PCB using a via; however, ensure that the trace length from the pin to the capacitor is no greater than 0.25 inch (6 mm).
- **Handling high-frequency noise:** If the board is experiencing high-frequency noise (upward of tens of MHz), add a second ceramic type capacitor in parallel to the above described decoupling capacitor. The value of the second capacitor can be in the range of 0.01 μF to 0.001 μF . Place this second capacitor next to each primary decoupling capacitor. In high-speed circuit designs, consider implementing a decade pair of capacitances as close to the power and ground pins as possible (e.g., 0.1 μF in parallel with 0.001 μF).
- **Maximizing performance:** On the board layout from the power supply circuit, run the power and return traces to the decoupling capacitors first, and then to the device pins. This ensures that the decoupling capacitors are first in the power chain. Equally important is to keep the trace length between the capacitor and the power pins to a minimum, thereby reducing PCB trace inductance.

2.2.2 TANK CAPACITORS

On boards with power traces running longer than six inches in length, it is suggested to use a tank capacitor for integrated circuits, including microcontrollers, to supply a local power source. The value of the tank capacitor should be determined based on the trace resistance that connects the power supply source to the device, and the maximum current drawn by the device in the application. In other words, select the tank capacitor so that it meets the acceptable voltage sag at the device. Typical values range from 4.7 μF to 47 μF .

2.3 Master Clear ($\overline{\text{MCLR}}$) Pin

The $\overline{\text{MCLR}}$ pin provides two specific device functions: device Reset, and device programming and debugging. If programming and debugging are not required in the end application, a direct connection to VDD may be all that is required. The addition of other components, to help increase the application's resistance to spurious Resets from voltage sags, may be beneficial. A typical configuration is shown in Figure 2-1. Other circuit designs may be implemented, depending on the application's requirements.

During programming and debugging, the resistance and capacitance that can be added to the pin must be considered. Device programmers and debuggers drive the $\overline{\text{MCLR}}$ pin. Consequently, specific voltage levels (V_{IH} and V_{IL}) and fast signal transitions must not be adversely affected. Therefore, specific values of R1 and C1 will need to be adjusted based on the application and PCB requirements. For example, it is recommended that the capacitor, C1, be isolated from the $\overline{\text{MCLR}}$ pin during programming and debugging operations by using a jumper (Figure 2-2). The jumper is replaced for normal run-time operations.

Any components associated with the $\overline{\text{MCLR}}$ pin should be placed within 0.25 inch (6 mm) of the pin.

FIGURE 2-2: EXAMPLE OF $\overline{\text{MCLR}}$ PIN CONNECTIONS

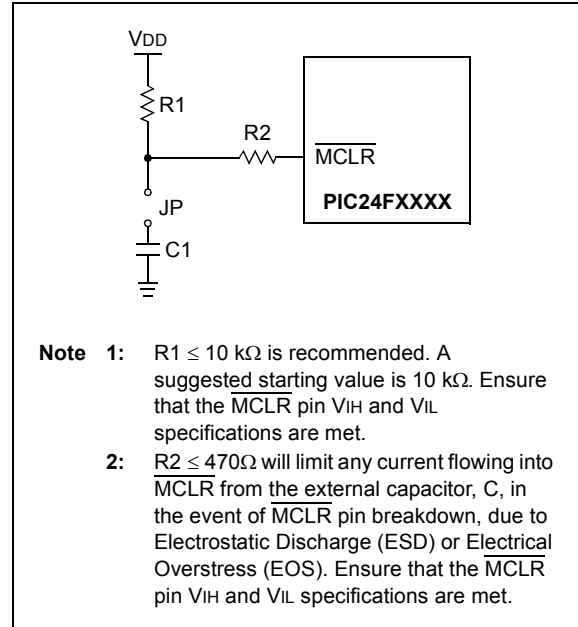

PIC24FJ128GA204 FAMILY

2.4 Voltage Regulator Pins (ENVREG/ DISVREG and VCAP/VDDCORE)

Note: This section applies only to PIC24FJ devices with an on-chip voltage regulator.

The on-chip voltage regulator enable/disable pin (ENVREG or DISVREG, depending on the device family) must always be connected directly to either a supply voltage or to ground. The particular connection is determined by whether or not the regulator is to be used:

- For ENVREG, tie to VDD to enable the regulator, or to ground to disable the regulator
- For DISVREG, tie to ground to enable the regulator or to VDD to disable the regulator

Refer to [Section 29.2 “On-Chip Voltage Regulator”](#) for details on connecting and using the on-chip regulator.

When the regulator is enabled, a low-ESR (< 5Ω) capacitor is required on the VCAP/VDDCORE pin to stabilize the voltage regulator output voltage. The VCAP/VDDCORE pin must not be connected to VDD and must use a capacitor of 10 μF connected to ground. The type can be ceramic or tantalum. Suitable examples of capacitors are shown in [Table 2-1](#). Capacitors with equivalent specifications can be used.

Designers may use [Figure 2-3](#) to evaluate ESR equivalence of candidate devices.

The placement of this capacitor should be close to VCAP/VDDCORE. It is recommended that the trace length not exceed 0.25 inch (6 mm). Refer to [Section 32.0 “Electrical Characteristics”](#) for additional information.

When the regulator is disabled, the VCAP/VDDCORE pin must be tied to a voltage supply at the VDDCORE level. Refer to [Section 32.0 “Electrical Characteristics”](#) for information on VDD and VDDCORE.

FIGURE 2-3: FREQUENCY vs. ESR PERFORMANCE FOR SUGGESTED VCAP

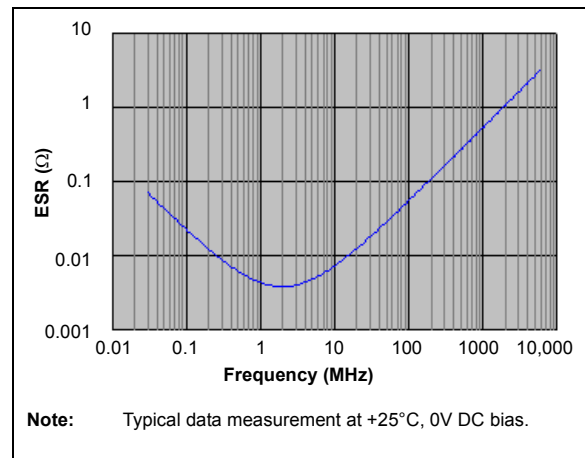

TABLE 2-1: SUITABLE CAPACITOR EQUIVALENTS

Make	Part #	Nominal Capacitance	Base Tolerance	Rated Voltage	Temp. Range
TDK	C3216X7R1C106K	10 μF	±10%	16V	-55 to +125°C
TDK	C3216X5R1C106K	10 μF	±10%	16V	-55 to +85°C
Panasonic	ECJ-3YX1C106K	10 μF	±10%	16V	-55 to +125°C
Panasonic	ECJ-4YB1C106K	10 μF	±10%	16V	-55 to +85°C
Murata	GRM32DR71C106KA01L	10 μF	±10%	16V	-55 to +125°C
Murata	GRM31CR61C106KC31L	10 μF	±10%	16V	-55 to +85°C

PIC24FJ128GA204 FAMILY

2.4.1 CONSIDERATIONS FOR CERAMIC CAPACITORS

In recent years, large value, low-voltage, surface-mount ceramic capacitors have become very cost effective in sizes up to a few tens of microfarad. The low-ESR, small physical size and other properties make ceramic capacitors very attractive in many types of applications.

Ceramic capacitors are suitable for use with the internal voltage regulator of this microcontroller. However, some care is needed in selecting the capacitor to ensure that it maintains sufficient capacitance over the intended operating range of the application.

Typical low-cost, 10 μ F ceramic capacitors are available in X5R, X7R and Y5V dielectric ratings (other types are also available, but are less common). The initial tolerance specifications for these types of capacitors are often specified as $\pm 10\%$ to $\pm 20\%$ (X5R and X7R) or $-20\%/+80\%$ (Y5V). However, the effective capacitance that these capacitors provide in an application circuit will also vary based on additional factors, such as the applied DC bias voltage and the temperature. The total in-circuit tolerance is, therefore, much wider than the initial tolerance specification.

The X5R and X7R capacitors typically exhibit satisfactory temperature stability (ex: $\pm 15\%$ over a wide temperature range, but consult the manufacturer's data sheets for exact specifications). However, Y5V capacitors typically have extreme temperature tolerance specifications of $+22\%/ -82\%$. Due to the extreme temperature tolerance, a 10 μ F nominal rated Y5V type capacitor may not deliver enough total capacitance to meet minimum internal voltage regulator stability and transient response requirements. Therefore, Y5V capacitors are not recommended for use with the internal regulator if the application must operate over a wide temperature range.

In addition to temperature tolerance, the effective capacitance of large value ceramic capacitors can vary substantially, based on the amount of DC voltage applied to the capacitor. This effect can be very significant, but is often overlooked or is not always documented.

Typical DC bias voltage vs. capacitance graph for X7R type capacitors is shown in [Figure 2-4](#).

FIGURE 2-4: DC BIAS VOLTAGE vs. CAPACITANCE CHARACTERISTICS

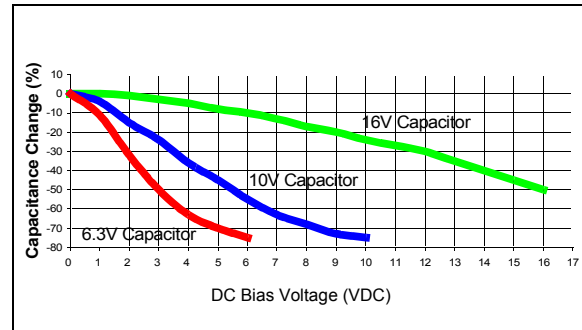

When selecting a ceramic capacitor to be used with the internal voltage regulator, it is suggested to select a high-voltage rating, so that the operating voltage is a small percentage of the maximum rated capacitor voltage. For example, choose a ceramic capacitor rated at 16V for the 2.5V or 1.8V core voltage. Suggested capacitors are shown in [Table 2-1](#).

2.5 ICSP Pins

The PGECx and PGEDx pins are used for In-Circuit Serial Programming (ICSP) and debugging purposes. It is recommended to keep the trace length between the ICSP connector and the ICSP pins on the device as short as possible. If the ICSP connector is expected to experience an ESD event, a series resistor is recommended, with the value in the range of a few tens of ohms, not to exceed 100 Ω .

Pull-up resistors, series diodes and capacitors on the PGECx and PGEDx pins are not recommended as they will interfere with the programmer/debugger communications to the device. If such discrete components are an application requirement, they should be removed from the circuit during programming and debugging. Alternatively, refer to the AC/DC characteristics and timing requirements information in the respective device Flash programming specification for information on capacitive loading limits and pin Voltage Input High (VIH) and Voltage Input Low (VIL) requirements.

For device emulation, ensure that the "Communication Channel Select" (i.e., PGECx/PGEDx pins), programmed into the device, matches the physical connections for the ICSP to the Microchip debugger/emulator tool.

For more information on available Microchip development tools connection requirements, refer to [Section 30.0 "Development Support"](#).

2.6 External Oscillator Pins

Many microcontrollers have options for at least two oscillators: a high-frequency Primary Oscillator and a low-frequency Secondary Oscillator (refer to [Section 9.0 “Oscillator Configuration”](#) for details).

The oscillator circuit should be placed on the same side of the board as the device. Place the oscillator circuit close to the respective oscillator pins with no more than 0.5 inch (12 mm) between the circuit components and the pins. The load capacitors should be placed next to the oscillator itself, on the same side of the board.

Use a grounded copper pour around the oscillator circuit to isolate it from surrounding circuits. The grounded copper pour should be routed directly to the MCU ground. Do not run any signal traces or power traces inside the ground pour. Also, if using a two-sided board, avoid any traces on the other side of the board where the crystal is placed.

Layout suggestions are shown in [Figure 2-5](#). In-line packages may be handled with a single-sided layout that completely encompasses the oscillator pins. With fine-pitch packages, it is not always possible to completely surround the pins and components. A suitable solution is to tie the broken guard sections to a mirrored ground layer. In all cases, the guard trace(s) must be returned to ground.

In planning the application’s routing and I/O assignments, ensure that adjacent port pins, and other signals in close proximity to the oscillator, are benign (i.e., free of high frequencies, short rise and fall times and other similar noise).

For additional information and design guidance on oscillator circuits, please refer to these Microchip Application Notes, available at the corporate web site (www.microchip.com):

- AN826, “Crystal Oscillator Basics and Crystal Selection for rPIC™ and PICmicro® Devices”
- AN849, “Basic PICmicro® Oscillator Design”
- AN943, “Practical PICmicro® Oscillator Analysis and Design”
- AN949, “Making Your Oscillator Work”

FIGURE 2-5: SUGGESTED PLACEMENT OF THE OSCILLATOR CIRCUIT

