



Chipsmall Limited consists of a professional team with an average of over 10 year of expertise in the distribution of electronic components. Based in Hongkong, we have already established firm and mutual-benefit business relationships with customers from,Europe,America and south Asia,supplying obsolete and hard-to-find components to meet their specific needs.

With the principle of “Quality Parts,Customers Priority,Honest Operation,and Considerate Service”,our business mainly focus on the distribution of electronic components. Line cards we deal with include Microchip,ALPS,ROHM,Xilinx,Pulse,ON,Everlight and Freescale. Main products comprise IC,Modules,Potentiometer,IC Socket,Relay,Connector.Our parts cover such applications as commercial,industrial, and automotives areas.

We are looking forward to setting up business relationship with you and hope to provide you with the best service and solution. Let us make a better world for our industry!



Contact us

Tel: +86-755-8981 8866 Fax: +86-755-8427 6832

Email & Skype: info@chipsmall.com Web: www.chipsmall.com

Address: A1208, Overseas Decoration Building, #122 Zhenhua RD., Futian, Shenzhen, China



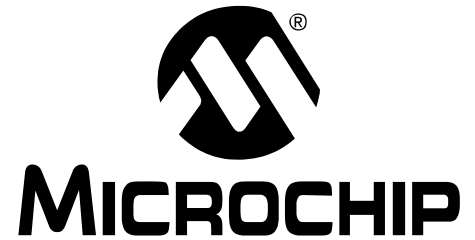

PIC24HJXXXGPX06/X08/X10
Data Sheet

High-Performance,
16-Bit Microcontrollers

Note the following details of the code protection feature on Microchip devices:

- Microchip products meet the specification contained in their particular Microchip Data Sheet.
- Microchip believes that its family of products is one of the most secure families of its kind on the market today, when used in the intended manner and under normal conditions.
- There are dishonest and possibly illegal methods used to breach the code protection feature. All of these methods, to our knowledge, require using the Microchip products in a manner outside the operating specifications contained in Microchip's Data Sheets. Most likely, the person doing so is engaged in theft of intellectual property.
- Microchip is willing to work with the customer who is concerned about the integrity of their code.
- Neither Microchip nor any other semiconductor manufacturer can guarantee the security of their code. Code protection does not mean that we are guaranteeing the product as "unbreakable."

Code protection is constantly evolving. We at Microchip are committed to continuously improving the code protection features of our products. Attempts to break Microchip's code protection feature may be a violation of the Digital Millennium Copyright Act. If such acts allow unauthorized access to your software or other copyrighted work, you may have a right to sue for relief under that Act.

Information contained in this publication regarding device applications and the like is provided only for your convenience and may be superseded by updates. It is your responsibility to ensure that your application meets with your specifications. MICROCHIP MAKES NO REPRESENTATIONS OR WARRANTIES OF ANY KIND WHETHER EXPRESS OR IMPLIED, WRITTEN OR ORAL, STATUTORY OR OTHERWISE, RELATED TO THE INFORMATION, INCLUDING BUT NOT LIMITED TO ITS CONDITION, QUALITY, PERFORMANCE, MERCHANTABILITY OR FITNESS FOR PURPOSE. Microchip disclaims all liability arising from this information and its use. Use of Microchip devices in life support and/or safety applications is entirely at the buyer's risk, and the buyer agrees to defend, indemnify and hold harmless Microchip from any and all damages, claims, suits, or expenses resulting from such use. No licenses are conveyed, implicitly or otherwise, under any Microchip intellectual property rights.

Trademarks

The Microchip name and logo, the Microchip logo, Accuron, dsPIC, KEELOQ, KEELOQ logo, MPLAB, PIC, PICmicro, PICSTART, rPIC, SmartShunt and UNI/O are registered trademarks of Microchip Technology Incorporated in the U.S.A. and other countries.

FilterLab, Linear Active Thermistor, MXDEV, MXLAB, SEEVAL, SmartSensor and The Embedded Control Solutions Company are registered trademarks of Microchip Technology Incorporated in the U.S.A.

Analog-for-the-Digital Age, Application Maestro, CodeGuard, dsPICDEM, dsPICDEM.net, dsPICworks, dsSPEAK, ECAN, ECONOMONITOR, FanSense, In-Circuit Serial Programming, ICSP, ICEPIC, Mindi, MiWi, MPASM, MPLAB Certified logo, MPLIB, MPLINK, mTouch, nanoWatt XLP, PICKit, PICDEM, PICDEM.net, PICTail, PIC³² logo, PowerCal, PowerInfo, PowerMate, PowerTool, REAL ICE, rLAB, Select Mode, Total Endurance, TSHARC, WiperLock and ZENA are trademarks of Microchip Technology Incorporated in the U.S.A. and other countries.

SQTP is a service mark of Microchip Technology Incorporated in the U.S.A.

All other trademarks mentioned herein are property of their respective companies.

© 2009, Microchip Technology Incorporated, Printed in the U.S.A., All Rights Reserved.

 Printed on recycled paper.

QUALITY MANAGEMENT SYSTEM
CERTIFIED BY DNV
== ISO/TS 16949:2002 ==

Microchip received ISO/TS-16949:2002 certification for its worldwide headquarters, design and wafer fabrication facilities in Chandler and Tempe, Arizona; Gresham, Oregon and design centers in California and India. The Company's quality system processes and procedures are for its PIC® MCUs and dsPIC® DSCs, KEELOQ® code hopping devices, Serial EEPROMs, microperipherals, nonvolatile memory and analog products. In addition, Microchip's quality system for the design and manufacture of development systems is ISO 9001:2000 certified.



MICROCHIP PIC24HJXXXGPX06/X08/X10

High-Performance, 16-Bit Microcontrollers

Operating Range:

- Up to 40 MIPS operation (at 3.0-3.6V):
 - Industrial temperature range (-40°C to +85°C)

High-Performance CPU:

- Modified Harvard architecture
- C compiler optimized instruction set
- 16-bit wide data path
- 24-bit wide instructions
- Linear program memory addressing up to 4M instruction words
- Linear data memory addressing up to 64 Kbytes
- 71 base instructions: mostly 1 word/1 cycle
- Sixteen 16-bit General Purpose Registers
- Flexible and powerful Indirect Addressing modes
- Software stack
- 16 x 16 multiply operations
- 32/16 and 16/16 divide operations
- Up to ± 16 -bit data shifts

Direct Memory Access (DMA):

- 8-channel hardware DMA
- 2 Kbytes dual ported DMA buffer area (DMA RAM) to store data transferred via DMA:
 - Allows data transfer between RAM and a peripheral while CPU is executing code (no cycle stealing)
- Most peripherals support DMA

Interrupt Controller:

- 5-cycle latency
- Up to 61 available interrupt sources
- Up to five external interrupts
- Seven programmable priority levels
- Five processor exceptions

Digital I/O:

- Up to 85 programmable digital I/O pins
- Wake-up/Interrupt-on-Change on up to 24 pins
- Output pins can drive from 3.0V to 3.6V
- All digital input pins are 5V tolerant
- 4 mA sink on all I/O pins

On-Chip Flash and SRAM:

- Flash program memory, up to 256 Kbytes
- Data SRAM, up to 16 Kbytes (includes 2 Kbytes of DMA RAM)

System Management:

- Flexible clock options:
 - External, crystal, resonator, internal RC
 - Fully integrated PLL
 - Extremely low jitter PLL
- Power-up Timer
- Oscillator Start-up Timer/Stabilizer
- Watchdog Timer with its own RC oscillator
- Fail-Safe Clock Monitor
- Reset by multiple sources

Power Management:

- On-chip 2.5V voltage regulator
- Switch between clock sources in real time
- Idle, Sleep and Doze modes with fast wake-up

Timers/Capture/Compare/PWM:

- Timer/Counters, up to nine 16-bit timers:
 - Can pair up to make four 32-bit timers
 - One timer runs as Real-Time Clock with external 32.768 kHz oscillator
 - Programmable prescaler
- Input Capture (up to eight channels):
 - Capture on up, down or both edges
 - 16-bit capture input functions
 - 4-deep FIFO on each capture
- Output Compare (up to eight channels):
 - Single or Dual 16-Bit Compare mode
 - 16-bit Glitchless PWM mode

PIC24HJXXXGPX06/X08/X10

Communication Modules:

- 3-wire SPI (up to two modules):
 - Framing supports I/O interface to simple codecs
 - Supports 8-bit and 16-bit data
 - Supports all serial clock formats and sampling modes
- I²C™ (up to two modules):
 - Full Multi-Master Slave mode support
 - 7-bit and 10-bit addressing
 - Bus collision detection and arbitration
 - Integrated signal conditioning
 - Slave address masking
- UART (up to two modules):
 - Interrupt on address bit detect
 - Interrupt on UART error
 - Wake-up on Start bit from Sleep mode
 - 4-character TX and RX FIFO buffers
 - LIN bus support
 - IrDA® encoding and decoding in hardware
 - High-Speed Baud mode
 - Hardware Flow Control with CTS and RTS
- Enhanced CAN (ECAN™ module) 2.0B active (up to two modules):
 - Up to eight transmit and up to 32 receive buffers
 - 16 receive filters and 3 masks
 - Loopback, Listen Only and Listen All Messages modes for diagnostics and bus monitoring
 - Wake-up on CAN message
 - Automatic processing of Remote Transmission Requests
 - FIFO mode using DMA
 - DeviceNet™ addressing support

Analog-to-Digital Converters:

- Up to two Analog-to-Digital Converter (ADC) modules in a device
- 10-bit, 1.1 Msps or 12-bit, 500 ksps conversion:
 - Two, four, or eight simultaneous samples
 - Up to 32 input channels with auto-scanning
 - Conversion start can be manual or synchronized with one of four trigger sources
 - Conversion possible in Sleep mode
 - ±1 LSB max integral nonlinearity
 - ±1 LSB max differential nonlinearity

CMOS Flash Technology:

- Low-power, high-speed Flash technology
- Fully static design
- 3.3V (±10%) operating voltage
- Industrial temperature
- Low-power consumption

Packaging:

- 100-pin TQFP (14x14x1 mm and 12x12x1 mm)
- 64-pin TQFP (10x10x1 mm)

| |
|--|
| Note: See the device variant tables for exact peripheral features per device. |
|--|

PIC24HJXXXGPX06/X08/X10

PIC24H PRODUCT FAMILIES

The PIC24H Family of devices is ideal for a wide variety of 16-bit MCU embedded applications. The device names, pin counts, memory sizes and peripheral availability of each device are listed below, followed by their pinout diagrams.

PIC24H Family Controllers

| Device | Pins | Program Flash Memory (KB) | RAM ⁽¹⁾ (KB) | DMA Channels | Timer 16-bit | Input Capture | Output Compare Std. PWM | Codec Interface | ADC | UART | SPI | I ² C™ | CAN | I/O Pins (Max) ⁽²⁾ | Packages |
|-----------------|------|---------------------------|-------------------------|--------------|--------------|---------------|-------------------------|-----------------|--------------|------|-----|-------------------|-----|-------------------------------|----------|
| PIC24HJ64GP206 | 64 | 64 | 8 | 8 | 9 | 8 | 8 | 0 | 1 ADC, 18 ch | 2 | 2 | 1 | 0 | 53 | PT |
| PIC24HJ64GP210 | 100 | 64 | 8 | 8 | 9 | 8 | 8 | 0 | 1 ADC, 32 ch | 2 | 2 | 2 | 0 | 85 | PF, PT |
| PIC24HJ64GP506 | 64 | 64 | 8 | 8 | 9 | 8 | 8 | 0 | 1 ADC, 18 ch | 2 | 2 | 2 | 1 | 53 | PT |
| PIC24HJ64GP510 | 100 | 64 | 8 | 8 | 9 | 8 | 8 | 0 | 1 ADC, 32 ch | 2 | 2 | 2 | 1 | 85 | PF, PT |
| PIC24HJ128GP206 | 64 | 128 | 8 | 8 | 9 | 8 | 8 | 0 | 1 ADC, 18 ch | 2 | 2 | 2 | 0 | 53 | PT |
| PIC24HJ128GP210 | 100 | 128 | 8 | 8 | 9 | 8 | 8 | 0 | 1 ADC, 32 ch | 2 | 2 | 2 | 0 | 85 | PF, PT |
| PIC24HJ128GP506 | 64 | 128 | 8 | 8 | 9 | 8 | 8 | 0 | 1 ADC, 18 ch | 2 | 2 | 2 | 1 | 53 | PT |
| PIC24HJ128GP510 | 100 | 128 | 8 | 8 | 9 | 8 | 8 | 0 | 1 ADC, 32 ch | 2 | 2 | 2 | 1 | 85 | PF, PT |
| PIC24HJ128GP306 | 64 | 128 | 16 | 8 | 9 | 8 | 8 | 0 | 1 ADC, 18 ch | 2 | 2 | 2 | 0 | 53 | PT |
| PIC24HJ128GP310 | 100 | 128 | 16 | 8 | 9 | 8 | 8 | 0 | 1 ADC, 32 ch | 2 | 2 | 2 | 0 | 85 | PF, PT |
| PIC24HJ256GP206 | 64 | 256 | 16 | 8 | 9 | 8 | 8 | 0 | 1 ADC, 18 ch | 2 | 2 | 2 | 0 | 53 | PT |
| PIC24HJ256GP210 | 100 | 256 | 16 | 8 | 9 | 8 | 8 | 0 | 1 ADC, 32 ch | 2 | 2 | 2 | 0 | 85 | PF, PT |
| PIC24HJ256GP610 | 100 | 256 | 16 | 8 | 9 | 8 | 8 | 0 | 2 ADC, 32 ch | 2 | 2 | 2 | 2 | 85 | PF, PT |

Note 1: RAM size is inclusive of 2 Kbytes DMA RAM.

Note 2: Maximum I/O pin count includes pins shared by the peripheral functions.

PIC24HJXXXGPX06/X08/X10

Pin Diagrams

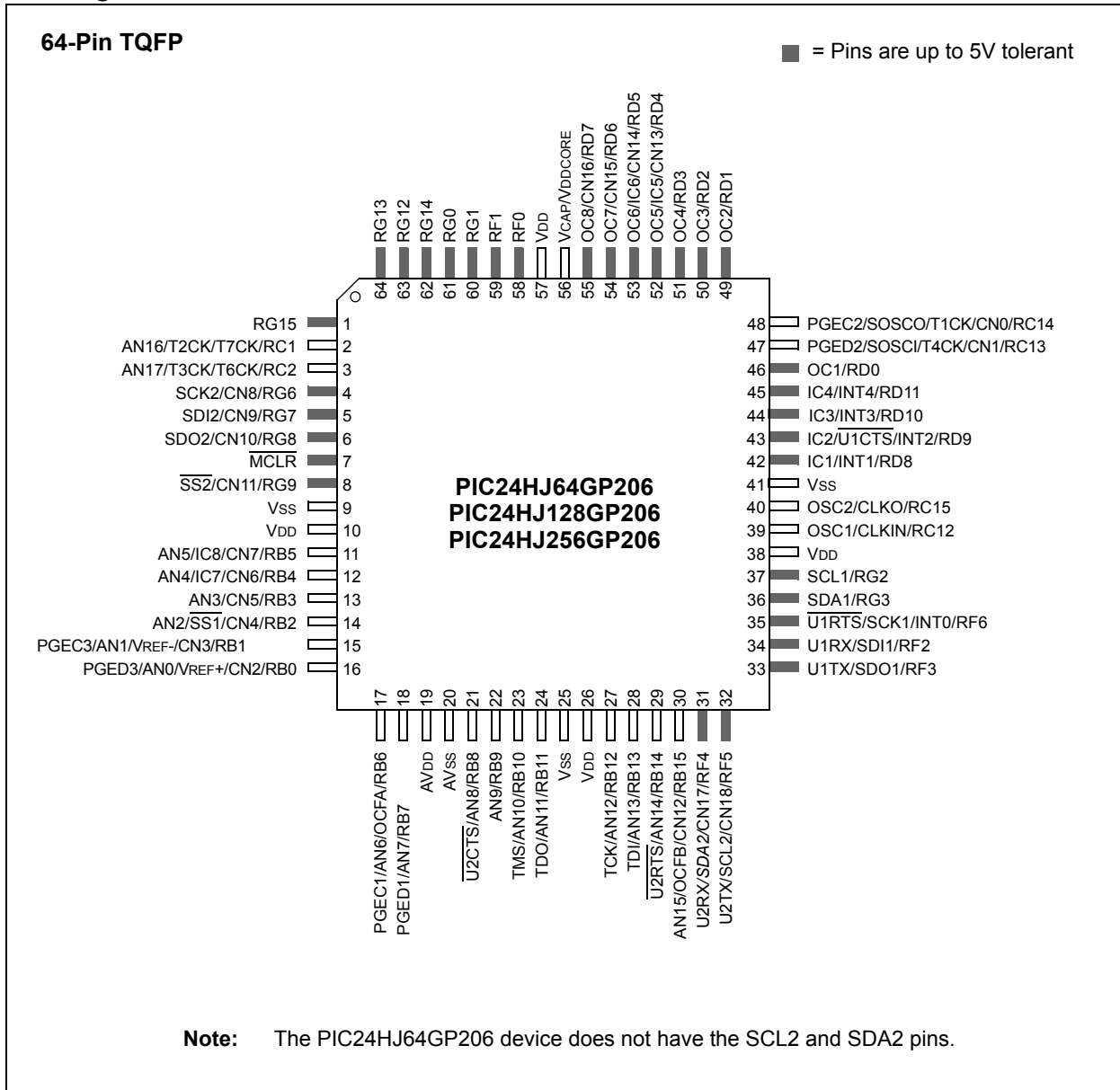

PIC24HJXXXGPX06/X08/X10

Pin Diagrams (Continued)

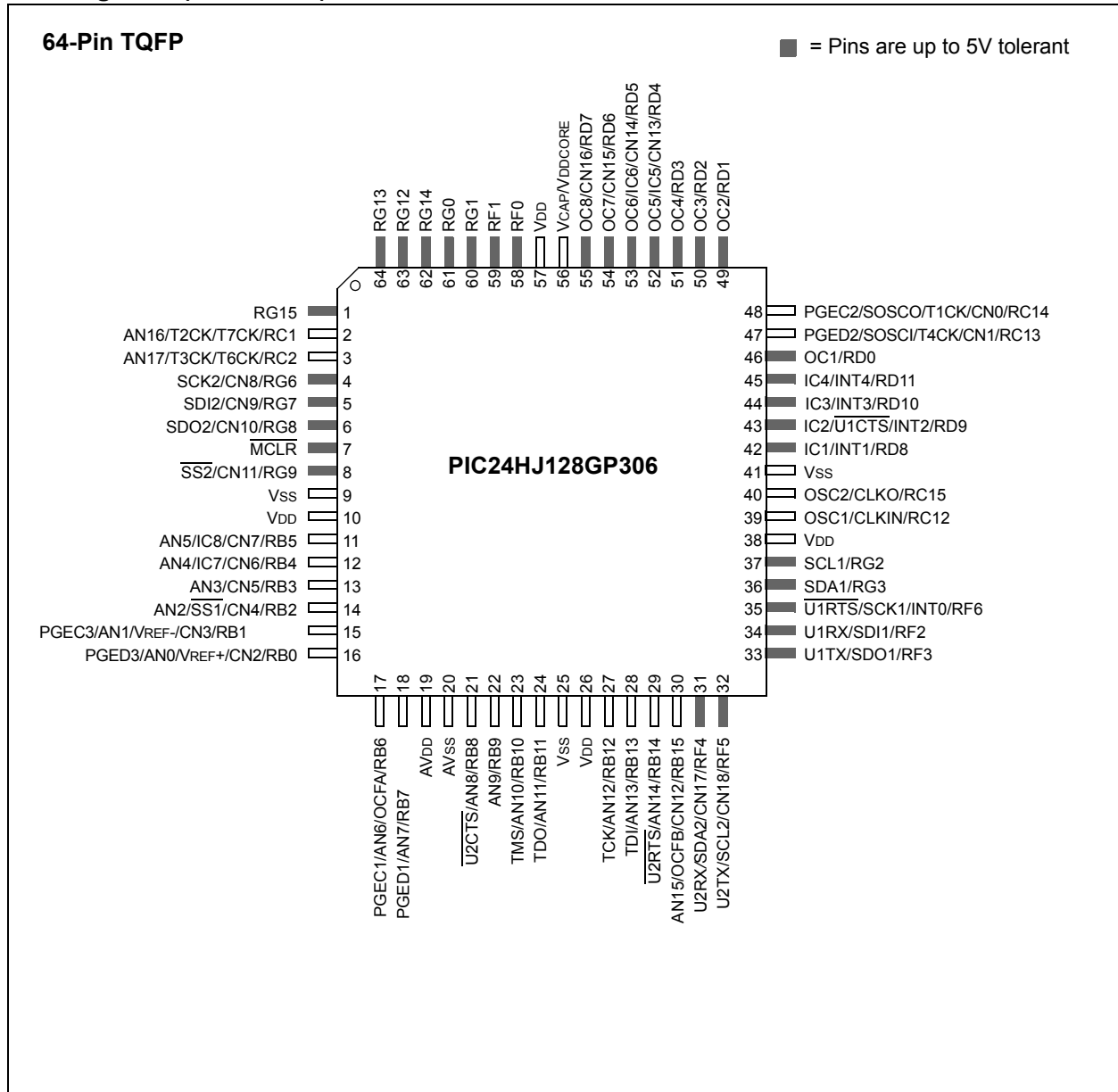

PIC24HJXXXGPX06/X08/X10

Pin Diagrams (Continued)

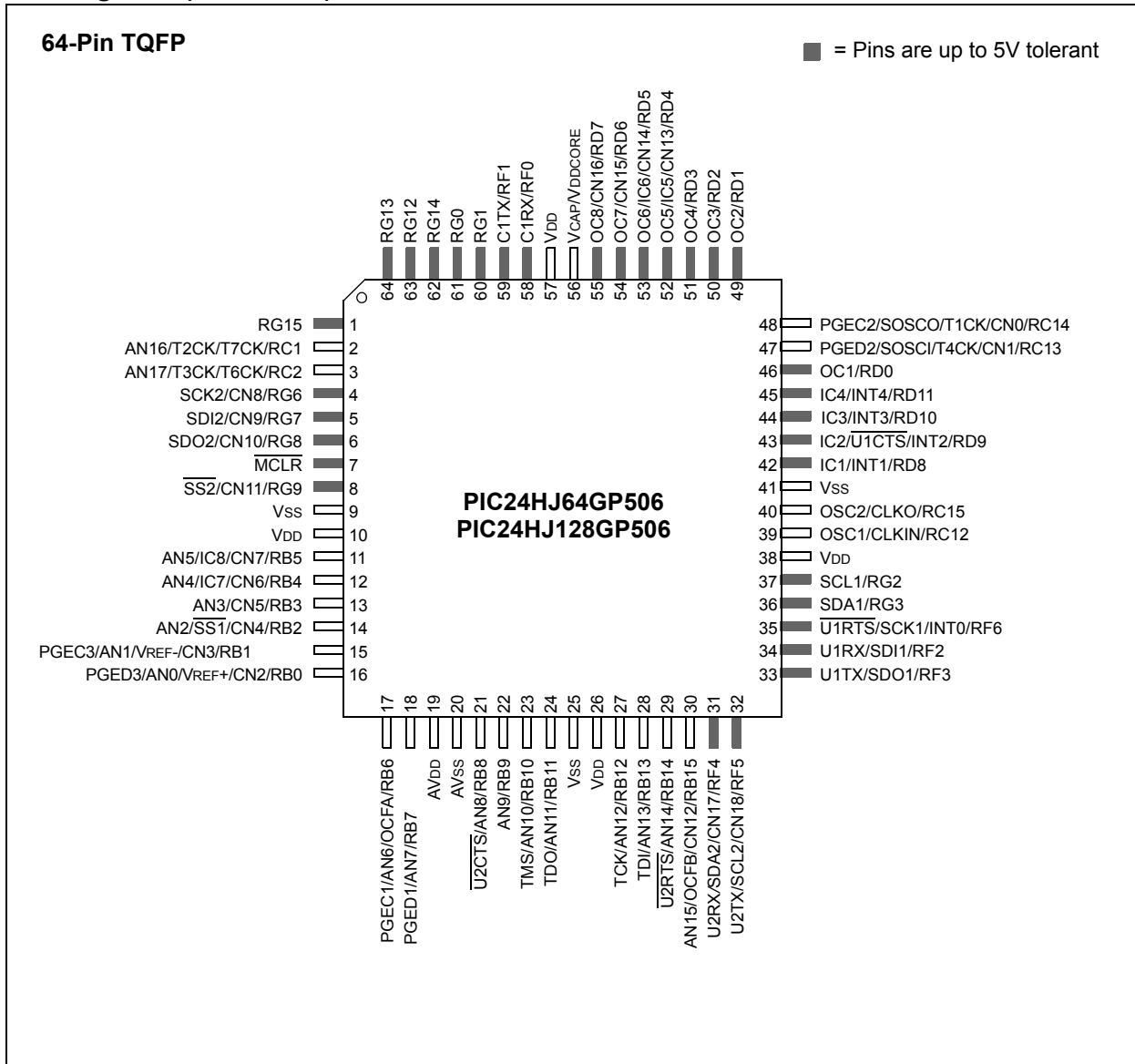

PIC24HJXXXGPX06/X08/X10

Pin Diagrams (Continued)

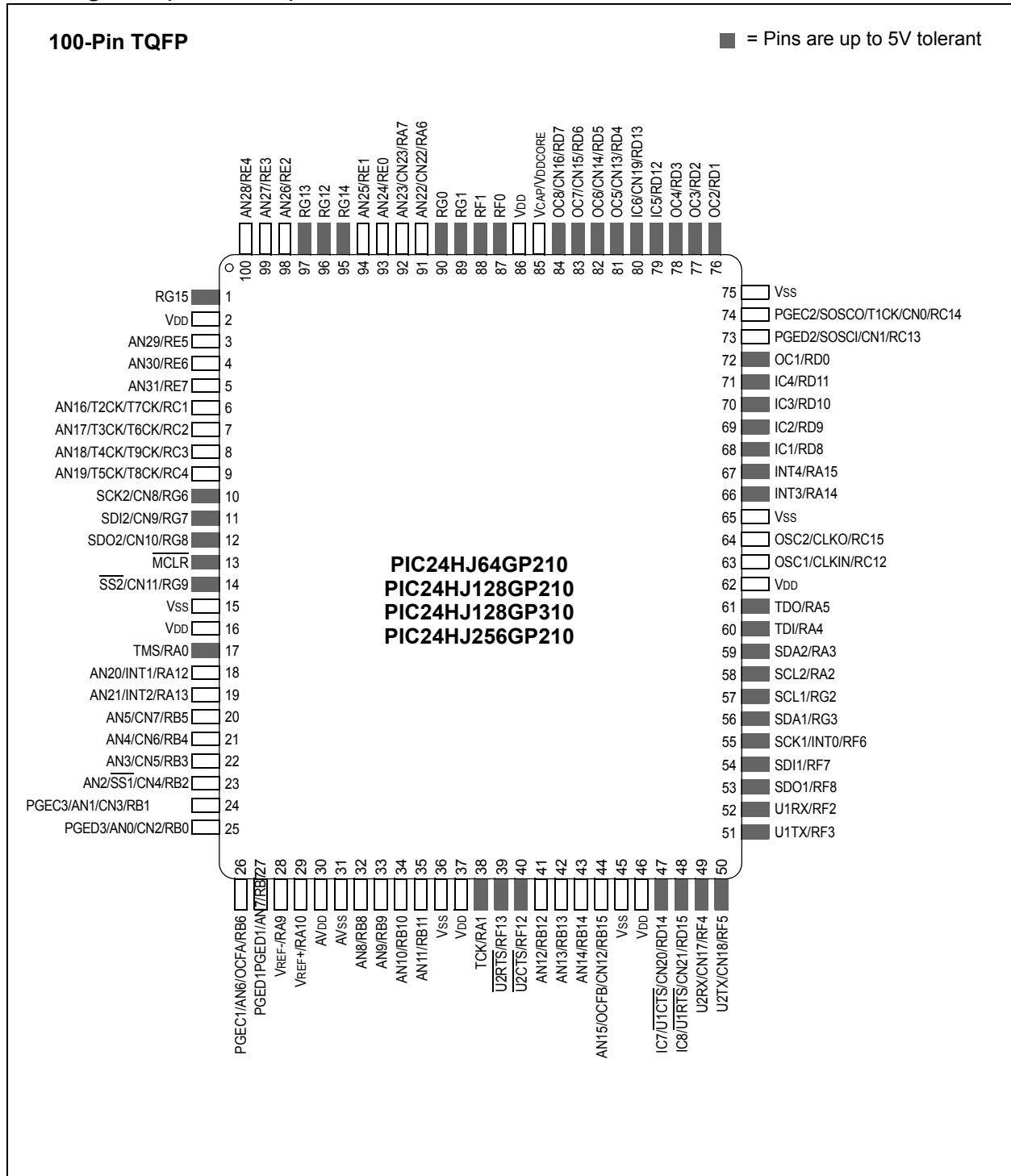

PIC24HJXXXGPX06/X08/X10

Pin Diagrams (Continued)

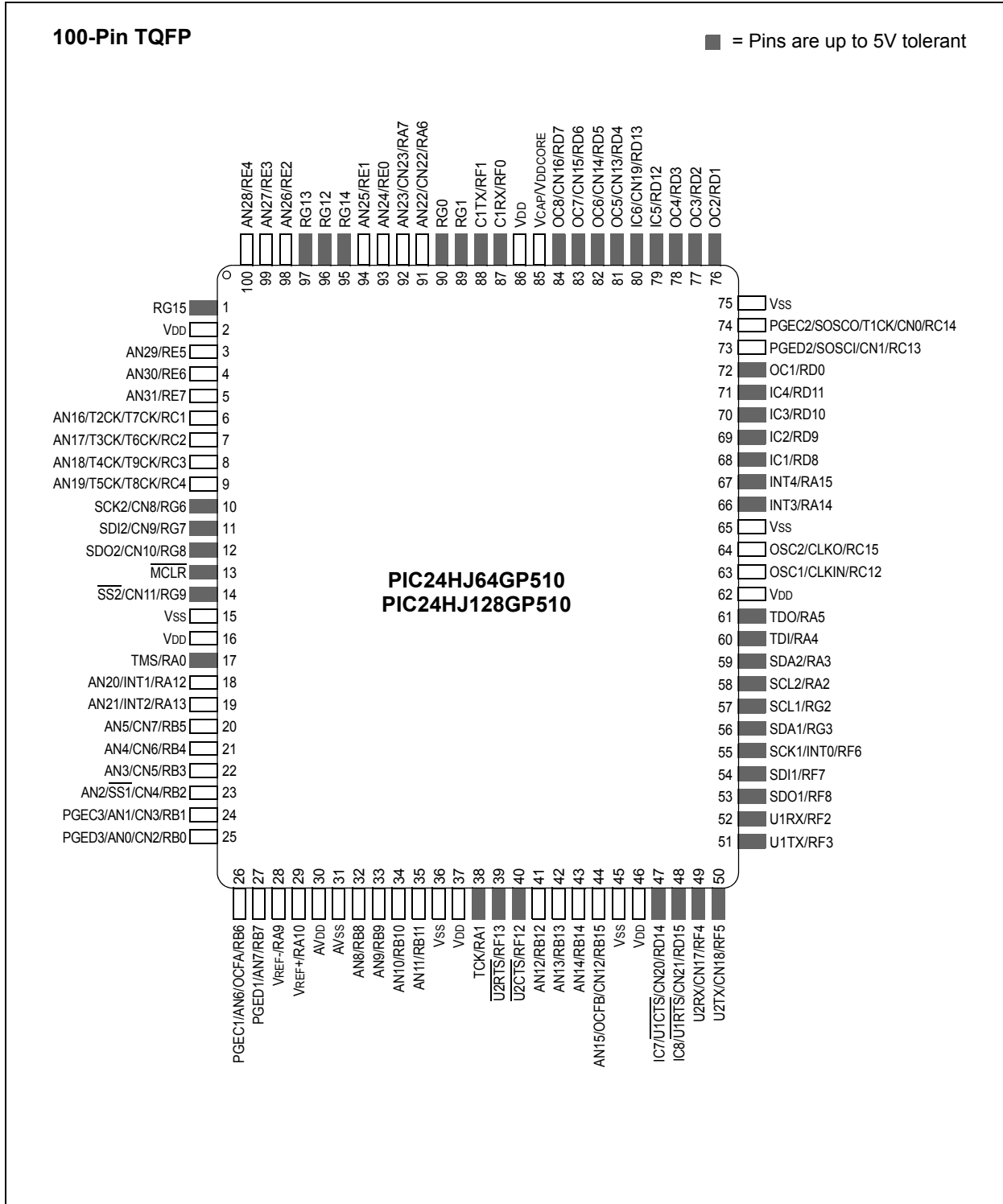

PIC24HJXXXGPX06/X08/X10

Pin Diagrams (Continued)

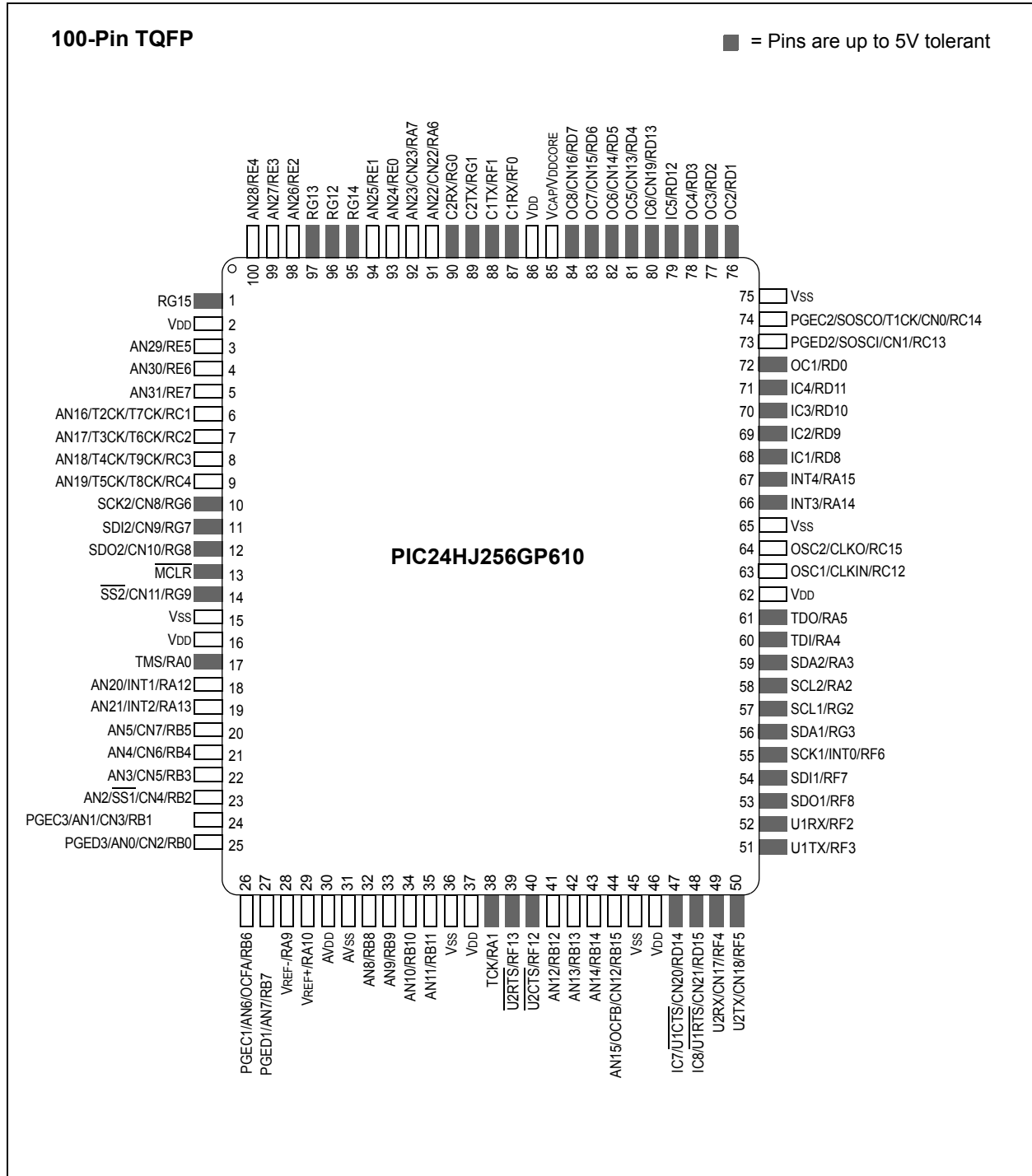

PIC24HJXXXGPX06/X08/X10

Table of Contents

| | |
|---|-----|
| PIC24H Product Families | 3 |
| 1.0 Device Overview | 11 |
| 2.0 Guidelines for Getting Started with 16-Bit Microcontrollers | 15 |
| 3.0 CPU | 19 |
| 4.0 Memory Organization | 25 |
| 5.0 Flash Program Memory | 55 |
| 6.0 Reset | 61 |
| 7.0 Interrupt Controller | 65 |
| 8.0 Direct Memory Access (DMA) | 109 |
| 9.0 Oscillator Configuration | 119 |
| 10.0 Power-Saving Features | 129 |
| 11.0 I/O Ports | 137 |
| 12.0 Timer1 | 139 |
| 13.0 Timer2/3, Timer4/5, Timer6/7 and Timer8/9 | 141 |
| 14.0 Input Capture | 147 |
| 15.0 Output Compare | 149 |
| 16.0 Serial Peripheral Interface (SPI) | 153 |
| 17.0 Inter-Integrated Circuit™ (I ² C™) | 159 |
| 18.0 Universal Asynchronous Receiver Transmitter (UART) | 167 |
| 19.0 Enhanced CAN (ECAN™) Module | 173 |
| 20.0 10-Bit/12-Bit Analog-to-Digital Converter (ADC) | 199 |
| 21.0 Special Features | 211 |
| 22.0 Instruction Set Summary | 219 |
| 23.0 Development Support | 227 |
| 24.0 Electrical Characteristics | 231 |
| 25.0 Packaging Information | 267 |
| Appendix A: Revision History | 275 |
| Index | 281 |
| The Microchip Web Site | 285 |
| Customer Change Notification Service | 285 |
| Customer Support | 285 |
| Reader Response | 286 |
| Product Identification System | 287 |

TO OUR VALUED CUSTOMERS

It is our intention to provide our valued customers with the best documentation possible to ensure successful use of your Microchip products. To this end, we will continue to improve our publications to better suit your needs. Our publications will be refined and enhanced as new volumes and updates are introduced.

If you have any questions or comments regarding this publication, please contact the Marketing Communications Department via E-mail at docerrors@microchip.com or fax the **Reader Response Form** in the back of this data sheet to (480) 792-4150. We welcome your feedback.

Most Current Data Sheet

To obtain the most up-to-date version of this data sheet, please register at our Worldwide Web site at:

<http://www.microchip.com>

You can determine the version of a data sheet by examining its literature number found on the bottom outside corner of any page. The last character of the literature number is the version number, (e.g., DS30000A is version A of document DS30000).

Errata

An errata sheet, describing minor operational differences from the data sheet and recommended workarounds, may exist for current devices. As device/documentation issues become known to us, we will publish an errata sheet. The errata will specify the revision of silicon and revision of document to which it applies.

To determine if an errata sheet exists for a particular device, please check with one of the following:

- Microchip's Worldwide Web site; <http://www.microchip.com>
- Your local Microchip sales office (see last page)

When contacting a sales office, please specify which device, revision of silicon and data sheet (include literature number) you are using.

Customer Notification System

Register on our web site at www.microchip.com to receive the most current information on all of our products.

PIC24HJXXXGPX06/X08/X10

1.0 DEVICE OVERVIEW

Note: This data sheet summarizes the features of the PIC24HJXXXGPX06/X08/X10 family of devices. However, it is not intended to be a comprehensive reference source. To complement the information in this data sheet, refer to the latest family reference sections of the “*PIC24H Family Reference Manual*”, which is available from the Microchip web site (www.microchip.com).

This document contains device specific information for the following devices:

- PIC24HJ64GP206
- PIC24HJ64GP210
- PIC24HJ64GP506
- PIC24HJ64GP510
- PIC24HJ128GP206
- PIC24HJ128GP210
- PIC24HJ128GP506
- PIC24HJ128GP510
- PIC24HJ128GP306
- PIC24HJ128GP310
- PIC24HJ256GP206
- PIC24HJ256GP210
- PIC24HJ256GP610

The PIC24HJXXXGPX06/X08/X10 device family includes devices with different pin counts (64 and 100 pins), different program memory sizes (64 Kbytes, 128 Kbytes and 256 Kbytes) and different RAM sizes (8 Kbytes and 16 Kbytes).

This makes these families suitable for a wide variety of high-performance digital signal control applications. The devices are pin compatible with the dsPIC33F family of devices, and also share a very high degree of compatibility with the dsPIC30F family devices. This allows easy migration between device families as may be necessitated by the specific functionality, computational resource and system cost requirements of the application.

The PIC24HJXXXGPX06/X08/X10 device family employs a powerful 16-bit architecture, ideal for applications that rely on high-speed, repetitive computations, as well as control.

The 17 x 17 multiplier, hardware support for division operations, multi-bit data shifter, a large array of 16-bit working registers and a wide variety of data addressing modes, together provide the PIC24HJXXXGPX06/X08/X10 Central Processing Unit (CPU) with extensive mathematical processing capability. Flexible and deterministic interrupt handling, coupled with a powerful array of peripherals, renders the PIC24HJXXXGPX06/X08/X10 devices suitable for control applications. Further, Direct Memory Access (DMA) enables overhead-free transfer of data between several peripherals and a dedicated DMA RAM. Reliable, field programmable Flash program memory ensures scalability of applications that use PIC24HJXXXGPX06/X08/X10 devices.

Figure 1-1 shows a general block diagram of the various core and peripheral modules in the PIC24HJXXXGPX06/X08/X10 family of devices, while Table 1-1 lists the functions of the various pins shown in the pinout diagrams.

PIC24HJXXXGPX06/X08/X10

FIGURE 1-1: PIC24HJXXXGPX06/X08/X10 GENERAL BLOCK DIAGRAM

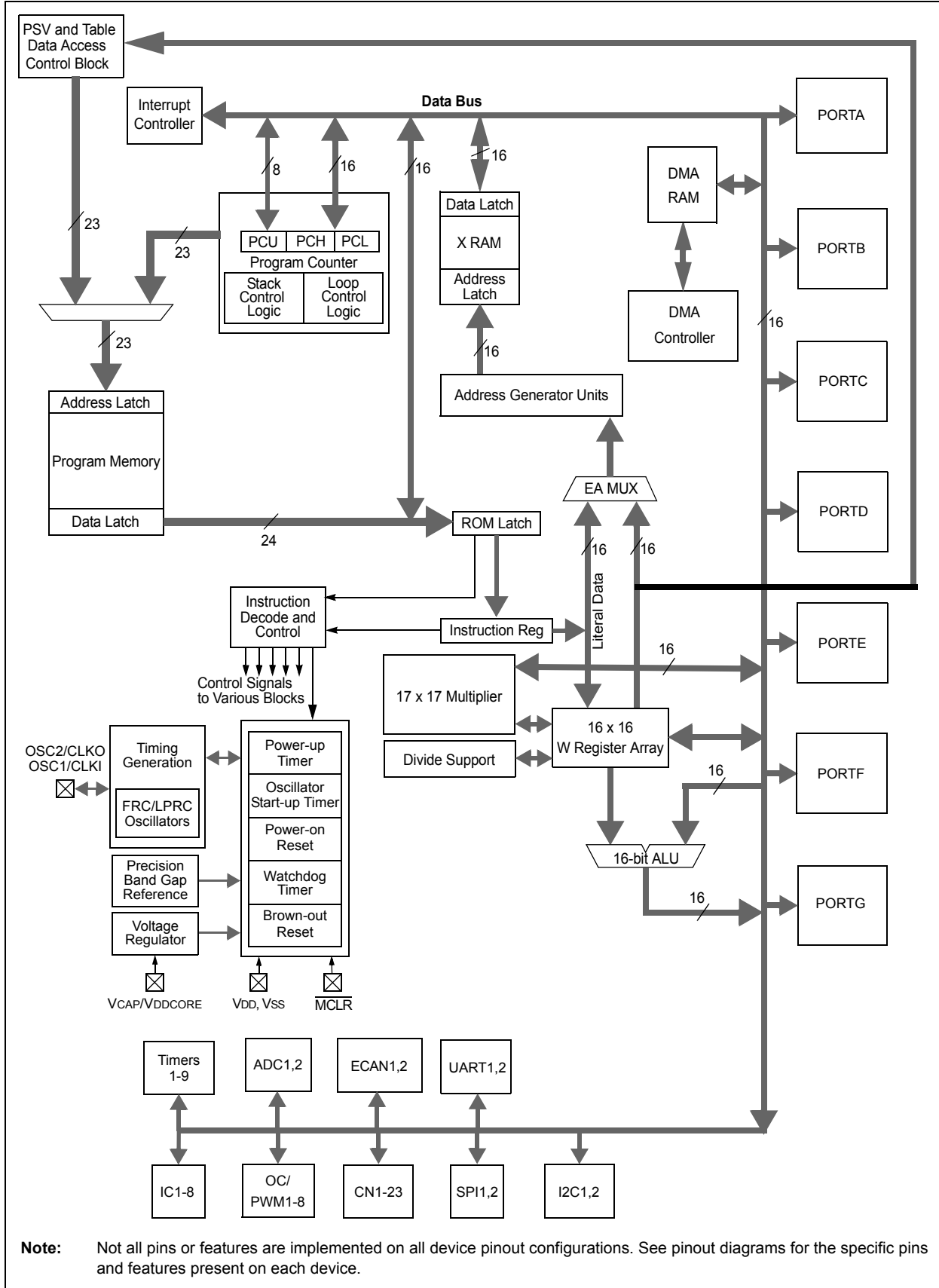

PIC24HJXXXGPX06/X08/X10

TABLE 1-1: PINOUT I/O DESCRIPTIONS

| Pin Name | Pin Type | Buffer Type | Description |
|-----------|----------|-------------|--|
| AN0-AN31 | I | Analog | Analog input channels. |
| AVDD | P | P | Positive supply for analog modules. This pin must be connected at all times. |
| AVSS | P | P | Ground reference for analog modules. |
| CLKI | I | ST/CMOS | External clock source input. Always associated with OSC1 pin function. |
| CLKO | O | — | Oscillator crystal output. Connects to crystal or resonator in Crystal Oscillator mode. Optionally functions as CLKO in RC and EC modes. Always associated with OSC2 pin function. |
| CN0-CN23 | I | ST | Input change notification inputs. Can be software programmed for internal weak pull-ups on all inputs. |
| C1RX | I | ST | ECAN1 bus receive pin. |
| C1TX | O | — | ECAN1 bus transmit pin. |
| C2RX | I | ST | ECAN2 bus receive pin. |
| C2TX | O | — | ECAN2 bus transmit pin. |
| PGED1 | I/O | ST | Data I/O pin for programming/debugging communication channel 1. |
| PGEC1 | I | ST | Clock input pin for programming/debugging communication channel 1. |
| PGED2 | I/O | ST | Data I/O pin for programming/debugging communication channel 2. |
| PGEC2 | I | ST | Clock input pin for programming/debugging communication channel 2. |
| PGED3 | I/O | ST | Data I/O pin for programming/debugging communication channel 3. |
| PGEC3 | I | ST | Clock input pin for programming/debugging communication channel 3. |
| IC1-IC8 | I | ST | Capture inputs 1 through 8. |
| INT0 | I | ST | External interrupt 0. |
| INT1 | I | ST | External interrupt 1. |
| INT2 | I | ST | External interrupt 2. |
| INT3 | I | ST | External interrupt 3. |
| INT4 | I | ST | External interrupt 4. |
| MCLR | I/P | ST | Master Clear (Reset) input. This pin is an active-low Reset to the device. |
| OCFA | I | ST | Compare Fault A input (for Compare Channels 1, 2, 3 and 4). |
| OCFB | I | ST | Compare Fault B input (for Compare Channels 5, 6, 7 and 8). |
| OC1-OC8 | O | — | Compare outputs 1 through 8. |
| OSC1 | I | ST/CMOS | Oscillator crystal input. ST buffer when configured in RC mode; CMOS otherwise. |
| OSC2 | I/O | — | Oscillator crystal output. Connects to crystal or resonator in Crystal Oscillator mode. Optionally functions as CLKO in RC and EC modes. |
| RA0-RA7 | I/O | ST | PORTA is a bidirectional I/O port. |
| RA9-RA10 | I/O | ST | |
| RA12-RA15 | I/O | ST | |
| RB0-RB15 | I/O | ST | PORTB is a bidirectional I/O port. |
| RC1-RC4 | I/O | ST | PORTC is a bidirectional I/O port. |
| RC12-RC15 | I/O | ST | |
| RD0-RD15 | I/O | ST | PORTD is a bidirectional I/O port. |
| RE0-RE7 | I/O | ST | PORTE is a bidirectional I/O port. |
| RF0-RF8 | I/O | ST | PORTF is a bidirectional I/O port. |
| RF12-RF13 | I/O | ST | |
| RG0-RG3 | I/O | ST | PORTG is a bidirectional I/O port. |
| RG6-RG9 | I/O | ST | |
| RG12-RG15 | I/O | ST | |

Legend: CMOS = CMOS compatible input or output Analog = Analog input P = Power
ST = Schmitt Trigger input with CMOS levels O = Output I = Input

PIC24HJXXXGPX06/X08/X10

TABLE 1-1: PINOUT I/O DESCRIPTIONS (CONTINUED)

| Pin Name | Pin Type | Buffer Type | Description |
|--------------|----------|-------------|--|
| SCK1 | I/O | ST | Synchronous serial clock input/output for SPI1. |
| SDI1 | I | ST | SPI1 data in. |
| SDO1 | O | — | SPI1 data out. |
| SS1 | I/O | ST | SPI1 slave synchronization or frame pulse I/O. |
| SCK2 | I/O | ST | Synchronous serial clock input/output for SPI2. |
| SDI2 | I | ST | SPI2 data in. |
| SDO2 | O | — | SPI2 data out. |
| SS2 | I/O | ST | SPI2 slave synchronization or frame pulse I/O. |
| SCL1 | I/O | ST | Synchronous serial clock input/output for I2C1. |
| SDA1 | I/O | ST | Synchronous serial data input/output for I2C1. |
| SCL2 | I/O | ST | Synchronous serial clock input/output for I2C2. |
| SDA2 | I/O | ST | Synchronous serial data input/output for I2C2. |
| SOSCI | I | ST/CMOS | 32.768 kHz low-power oscillator crystal input; CMOS otherwise. |
| SOSCO | O | — | 32.768 kHz low-power oscillator crystal output. |
| TMS | I | ST | JTAG Test mode select pin. |
| TCK | I | ST | JTAG test clock input pin. |
| TDI | I | ST | JTAG test data input pin. |
| TDO | O | — | JTAG test data output pin. |
| T1CK | I | ST | Timer1 external clock input. |
| T2CK | I | ST | Timer2 external clock input. |
| T3CK | I | ST | Timer3 external clock input. |
| T4CK | I | ST | Timer4 external clock input. |
| T5CK | I | ST | Timer5 external clock input. |
| T6CK | I | ST | Timer6 external clock input. |
| T7CK | I | ST | Timer7 external clock input. |
| T8CK | I | ST | Timer8 external clock input. |
| T9CK | I | ST | Timer9 external clock input. |
| U1CTS | I | ST | UART1 clear to send. |
| U1RTS | O | — | UART1 ready to send. |
| U1RX | I | ST | UART1 receive. |
| U1TX | O | — | UART1 transmit. |
| U2CTS | I | ST | UART2 clear to send. |
| U2RTS | O | — | UART2 ready to send. |
| U2RX | I | ST | UART2 receive. |
| U2TX | O | — | UART2 transmit. |
| VDD | P | — | Positive supply for peripheral logic and I/O pins. |
| VCAP/VDDCORE | P | — | CPU logic filter capacitor connection. |
| VSS | P | — | Ground reference for logic and I/O pins. |
| VREF+ | I | Analog | Analog voltage reference (high) input. |
| VREF- | I | Analog | Analog voltage reference (low) input. |

Legend: CMOS = CMOS compatible input or output Analog = Analog input P = Power
ST = Schmitt Trigger input with CMOS levels O = Output I = Input

2.0 GUIDELINES FOR GETTING STARTED WITH 16-BIT MICROCONTROLLERS

Note: This data sheet summarizes the features of the PIC24HJXXXGPX06/X08/X10 family of devices. It is not intended to be a comprehensive reference source. To complement the information in this data sheet, refer to the “PIC24H Family Reference Manual”, which is available from the Microchip website (www.microchip.com).

2.1 Basic Connection Requirements

Getting started with the PIC24HJXXXGPX06/X08/X10 family of 16-bit Microcontrollers (MCUs) requires attention to a minimal set of device pin connections before proceeding with development. The following is a list of pin names, which must always be connected:

- All VDD and VSS pins (see **Section 2.2 “Decoupling Capacitors”**)
- All AVDD and AVSS pins (regardless if ADC module is not used) (see **Section 2.2 “Decoupling Capacitors”**)
- VCAP/VDDCORE (see **Section 2.3 “Capacitor on Internal Voltage Regulator (VCAP/VDDCORE)”**)
- MCLR pin (see **Section 2.4 “Master Clear (MCLR) Pin”**)
- PGECx/PGEDx pins used for In-Circuit Serial Programming™ (ICSP™) and debugging purposes (see **Section 2.5 “ICSP Pins”**)
- OSC1 and OSC2 pins when external oscillator source is used (see **Section 2.6 “External Oscillator Pins”**)

Additionally, the following pins may be required:

- VREF+/VREF- pins used when external voltage reference for ADC module is implemented

Note: The AVDD and AVSS pins must be connected independent of the ADC voltage reference source.

2.2 Decoupling Capacitors

The use of decoupling capacitors on every pair of power supply pins, such as VDD, VSS, AVDD and AVSS is required.

Consider the following criteria when using decoupling capacitors:

- **Value and type of capacitor:** Recommendation of 0.1 μF (100 nF), 10-20V. This capacitor should be a low-ESR and have resonance frequency in the range of 20 MHz and higher. It is recommended that ceramic capacitors be used.
- **Placement on the printed circuit board:** The decoupling capacitors should be placed as close to the pins as possible. It is recommended to place the capacitors on the same side of the board as the device. If space is constricted, the capacitor can be placed on another layer on the PCB using a via; however, ensure that the trace length from the pin to the capacitor is within one-quarter inch (6 mm) in length.
- **Handling high frequency noise:** If the board is experiencing high frequency noise, upward of tens of MHz, add a second ceramic-type capacitor in parallel to the above described decoupling capacitor. The value of the second capacitor can be in the range of 0.01 μF to 0.001 μF . Place this second capacitor next to the primary decoupling capacitor. In high-speed circuit designs, consider implementing a decade pair of capacitances as close to the power and ground pins as possible. For example, 0.1 μF in parallel with 0.001 μF .
- **Maximizing performance:** On the board layout from the power supply circuit, run the power and return traces to the decoupling capacitors first, and then to the device pins. This ensures that the decoupling capacitors are first in the power chain. Equally important is to keep the trace length between the capacitor and the power pins to a minimum thereby reducing PCB track inductance.

PIC24HJXXXGPX06/X08/X10

FIGURE 2-1: RECOMMENDED MINIMUM CONNECTION

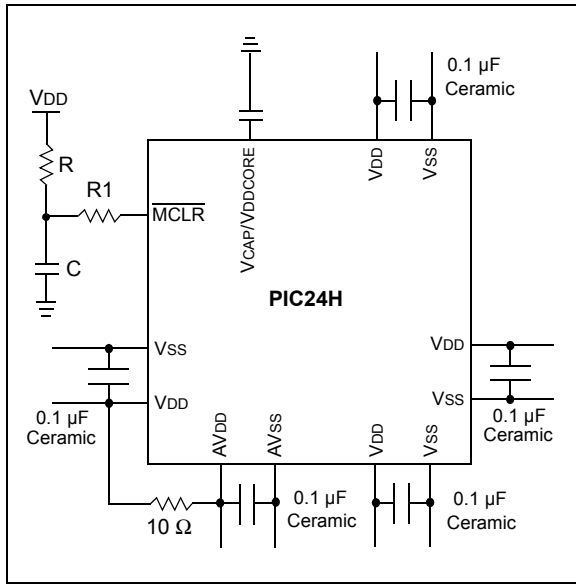

2.2.1 TANK CAPACITORS

On boards with power traces running longer than six inches in length, it is suggested to use a tank capacitor for integrated circuits including MCUs to supply a local power source. The value of the tank capacitor should be determined based on the trace resistance that connects the power supply source to the device, and the maximum current drawn by the device in the application. In other words, select the tank capacitor so that it meets the acceptable voltage sag at the device. Typical values range from 4.7 μF to 47 μF .

2.3 Capacitor on Internal Voltage Regulator (VCAP/VDDCORE)

A low-ESR (< 5 Ohms) capacitor is required on the VCAP/VDDCORE pin, which is used to stabilize the voltage regulator output voltage. The VCAP/VDDCORE pin must not be connected to VDD, and must have a capacitor between 4.7 μF and 10 μF , 16V connected to ground. The type can be ceramic or tantalum. Refer to **Section 24.0 “Electrical Characteristics”** for additional information.

The placement of this capacitor should be close to the VCAP/VDDCORE. It is recommended that the trace length not exceed one-quarter inch (6 mm). Refer to **Section 21.2 “On-Chip Voltage Regulator”** for details.

2.4 Master Clear (MCLR) Pin

The MCLR pin provides for two specific device functions:

- Device Reset
- Device programming and debugging

During device programming and debugging, the resistance and capacitance that can be added to the pin must be considered. Device programmers and debuggers drive the MCLR pin. Consequently, specific voltage levels (V_{IH} and V_{IL}) and fast signal transitions must not be adversely affected. Therefore, specific values of R and C will need to be adjusted based on the application and PCB requirements.

For example, as shown in Figure 2-2, it is recommended that the capacitor C, be isolated from the MCLR pin during programming and debugging operations.

Place the components shown in Figure 2-2 within one-quarter inch (6 mm) from the MCLR pin.

FIGURE 2-2: EXAMPLE OF MCLR PIN CONNECTIONS

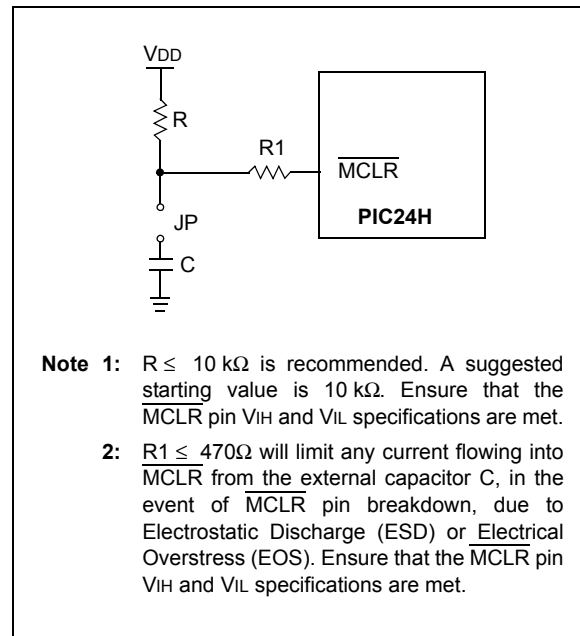

2.5 ICSP Pins

The PGECx and PGEDx pins are used for In-Circuit Serial Programming™ (ICSP™) and debugging purposes. It is recommended to keep the trace length between the ICSP connector and the ICSP pins on the device as short as possible. If the ICSP connector is expected to experience an ESD event, a series resistor is recommended, with the value in the range of a few tens of Ohms, not to exceed 100 Ohms.

Pull-up resistors, series diodes, and capacitors on the PGECx and PGEDx pins are not recommended as they will interfere with the programmer/debugger communications to the device. If such discrete components are an application requirement, they should be removed from the circuit during programming and debugging. Alternatively, refer to the AC/DC characteristics and timing requirements information in the respective device Flash programming specification for information on capacitive loading limits and pin input voltage high (V_{IH}) and input low (V_{IL}) requirements.

Ensure that the “Communication Channel Select” (i.e., PGECx/PGEDx pins) programmed into the device matches the physical connections for the ICSP to MPLAB® ICD 2, MPLAB ICD 3, or MPLAB REAL ICE™.

For more information on ICD 2, ICD 3 and REAL ICE connection requirements, refer to the following documents that are available on the Microchip website.

- “MPLAB® ICD 2 In-Circuit Debugger User’s Guide” DS51331
- “Using MPLAB® ICD 2” (poster) DS51265
- “MPLAB® ICD 2 Design Advisory” DS51566
- “Using MPLAB® ICD 3 In-Circuit Debugger” (poster) DS51765
- “MPLAB® ICD 3 Design Advisory” DS51764
- “MPLAB® REAL ICE™ In-Circuit Emulator User’s Guide” DS51616
- “Using MPLAB® REAL ICE™” (poster) DS51749

2.6 External Oscillator Pins

Many MCUs have options for at least two oscillators: a high-frequency primary oscillator and a low-frequency secondary oscillator (refer to **Section 9.0 “Oscillator Configuration”** for details).

The oscillator circuit should be placed on the same side of the board as the device. Also, place the oscillator circuit close to the respective oscillator pins, not exceeding one-half inch (12 mm) distance between them. The load capacitors should be placed next to the oscillator itself, on the same side of the board. Use a grounded copper pour around the oscillator circuit to isolate them from surrounding circuits. The grounded copper pour should be routed directly to the MCU ground. Do not run any signal traces or power traces inside the ground pour. Also, if using a two-sided board, avoid any traces on the other side of the board where the crystal is placed. A suggested layout is shown in Figure 2-3.

FIGURE 2-3: SUGGESTED PLACEMENT OF THE OSCILLATOR CIRCUIT

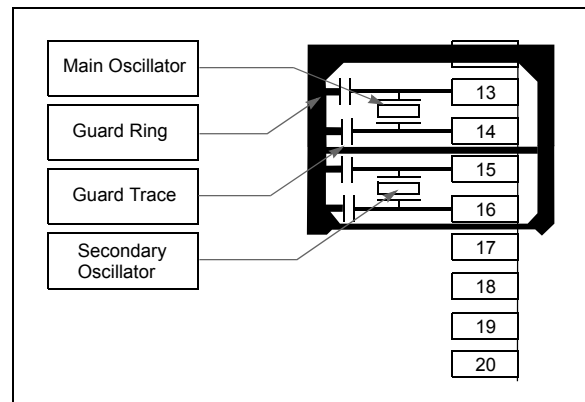

2.7 Oscillator Value Conditions on Device Start-up

If the PLL of the target device is enabled and configured for the device start-up oscillator, the maximum oscillator source frequency must be limited to $4 \text{ MHz} < F_{\text{IN}} < 8 \text{ MHz}$ to comply with device PLL start-up conditions. This means that if the external oscillator frequency is outside this range, the application must start-up in the FRC mode first. The default PLL settings after a POR with an oscillator frequency outside this range will violate the device operating speed.

Once the device powers up, the application firmware can initialize the PLL SFRs, CLKDIV and PLLDBF to a suitable value, and then perform a clock switch to the Oscillator + PLL clock source. Note that clock switching must be enabled in the device Configuration word.

2.8 Configuration of Analog and Digital Pins During ICSP Operations

If MPLAB ICD 2, ICD 3 or REAL ICE is selected as a debugger, it automatically initializes all of the A/D input pins (ANx) as “digital” pins, by setting all bits in the AD1PCFGL register.

The bits in this register that correspond to the A/D pins that are initialized by MPLAB ICD 2, ICD 3, or REAL ICE, must not be cleared by the user application firmware; otherwise, communication errors will result between the debugger and the device.

If your application needs to use certain A/D pins as analog input pins during the debug session, the user application must clear the corresponding bits in the AD1PCFGL register during initialization of the ADC module.

When MPLAB ICD 2, ICD 3 or REAL ICE is used as a programmer, the user application firmware must correctly configure the AD1PCFGL register. Automatic initialization of this register is only done during debugger operation. Failure to correctly configure the register(s) will result in all A/D pins being recognized as analog input pins, resulting in the port value being read as a logic ‘0’, which may affect user application functionality.

2.9 Unused I/Os

Unused I/O pins should be configured as outputs and driven to a logic-low state.

Alternatively, connect a 1k to 10k resistor to V_{SS} on unused pins and drive the output to logic low.

PIC24HJXXXGPX06/X08/X10

3.0 CPU

Note: This data sheet summarizes the features of the PIC24HJXXXGPX06/X08/X10 family of devices. However, it is not intended to be a comprehensive reference source. To complement the information in this data sheet, refer to the “PIC24H Family Reference Manual”, **Section 2. “CPU”** (DS70245), which is available from the Microchip website (www.microchip.com).

The PIC24HJXXXGPX06/X08/X10 CPU module has a 16-bit (data) modified Harvard architecture with an enhanced instruction set and addressing modes. The CPU has a 24-bit instruction word with a variable length opcode field. The Program Counter (PC) is 23 bits wide and addresses up to 4M x 24 bits of user program memory space. The actual amount of program memory implemented varies by device. A single-cycle instruction prefetch mechanism is used to help maintain throughput and provides predictable execution. All instructions execute in a single cycle, with the exception of instructions that change the program flow, the double word move (MOV.D) instruction and the table instructions. Overhead-free, single-cycle program loop constructs are supported using the REPEAT instruction, which is interruptible at any point.

The PIC24HJXXXGPX06/X08/X10 devices have sixteen, 16-bit working registers in the programmer's model. Each of the working registers can serve as a data, address or address offset register. The 16th working register (W15) operates as a software Stack Pointer (SP) for interrupts and calls.

The PIC24HJXXXGPX06/X08/X10 instruction set includes many addressing modes and is designed for optimum C compiler efficiency. For most instructions, the PIC24HJXXXGPX06/X08/X10 is capable of executing a data (or program data) memory read, a working register (data) read, a data memory write and a program (instruction) memory read per instruction cycle. As a result, three parameter instructions can be supported, allowing $A + B = C$ operations to be executed in a single cycle.

A block diagram of the CPU is shown in Figure 3-1, and the programmer's model for the PIC24HJXXXGPX06/X08/X10 is shown in Figure 3-2.

3.1 Data Addressing Overview

The data space can be linearly addressed as 32K words or 64 Kbytes using an Address Generation Unit (AGU). The upper 32 Kbytes of the data space memory map can optionally be mapped into program space at any 16K program word boundary defined by the 8-bit Program Space Visibility Page (PSVPAG) register. The program to data space mapping feature lets any instruction access program space as if it were data space.

The data space also includes 2 Kbytes of DMA RAM, which is primarily used for DMA data transfers, but may be used as general purpose RAM.

3.2 Special MCU Features

The PIC24HJXXXGPX06/X08/X10 features a 17-bit by 17-bit, single-cycle multiplier. The multiplier can perform signed, unsigned and mixed-sign multiplication. Using a 17-bit by 17-bit multiplier for 16-bit by 16-bit multiplication makes mixed-sign multiplication possible.

The PIC24HJXXXGPX06/X08/X10 supports 16/16 and 32/16 integer divide operations. All divide instructions are iterative operations. They must be executed within a REPEAT loop, resulting in a total execution time of 19 instruction cycles. The divide operation can be interrupted during any of those 19 cycles without loss of data.

A multi-bit data shifter is used to perform up to a 16-bit, left or right shift in a single cycle.

PIC24HJXXXGPX06/X08/X10

FIGURE 3-1: PIC24HJXXXGPX06/X08/X10 CPU CORE BLOCK DIAGRAM

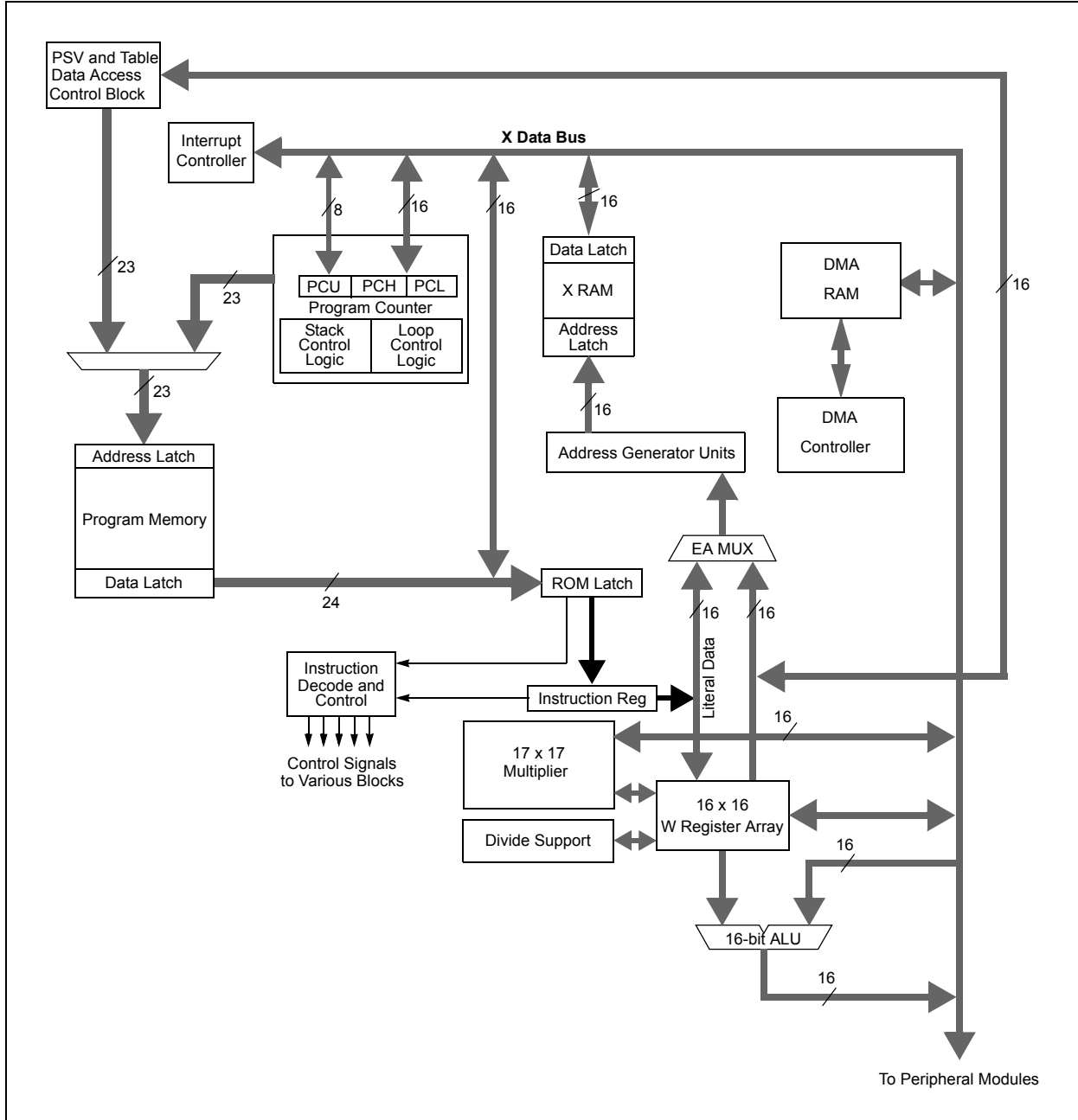

PIC24HJXXXGPX06/X08/X10

FIGURE 3-2: PIC24HJXXXGPX06/X08/X10 PROGRAMMER'S MODEL

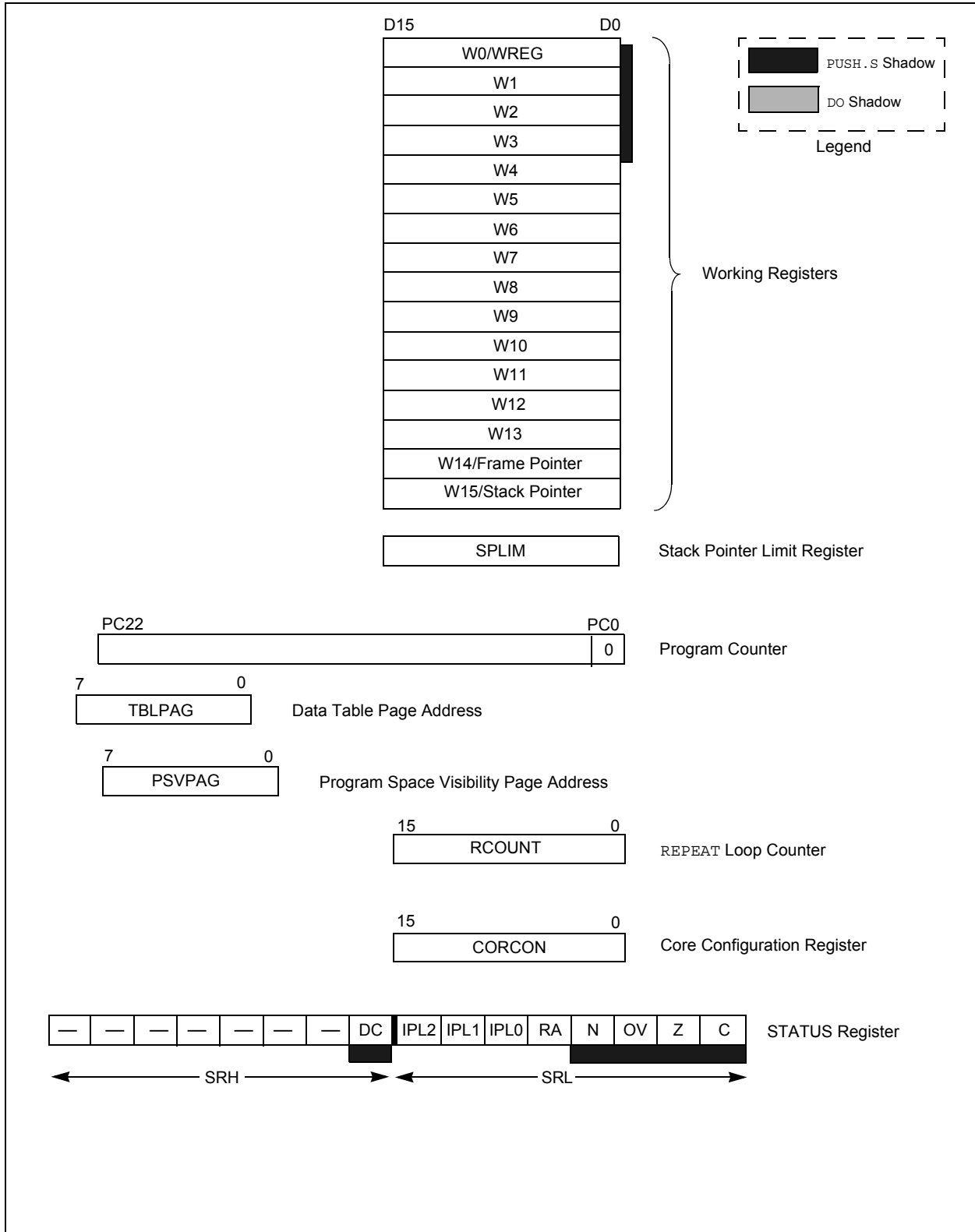

3.3 CPU Control Registers

PIC24HJXXXGPX06/X08/X10

REGISTER 3-1: SR: CPU STATUS REGISTER

| | | | | | | | |
|--------|-----|-----|-----|-----|-----|-----|-------|
| U-0 | U-0 | U-0 | U-0 | U-0 | U-0 | U-0 | R/W-0 |
| — | — | — | — | — | — | — | DC |
| bit 15 | | | | | | | bit 8 |

| | | | | | | | |
|-------------------------|----------------------|----------------------|-----|-------|-------|-------|-------|
| R/W-0 ⁽¹⁾ | R/W-0 ⁽²⁾ | R/W-0 ⁽²⁾ | R-0 | R/W-0 | R/W-0 | R/W-0 | R/W-0 |
| IPL<2:0> ⁽²⁾ | | | RA | N | OV | Z | C |
| bit 7 | | | | | | | bit 0 |

Legend:

| | | |
|--------------------|----------------------|------------------------------------|
| C = Clear only bit | R = Readable bit | U = Unimplemented bit, read as '0' |
| S = Set only bit | W = Writable bit | -n = Value at POR |
| '1' = Bit is set | '0' = Bit is cleared | x = Bit is unknown |

- bit 15-9 **Unimplemented:** Read as '0'
- bit 8 **DC:** MCU ALU Half Carry/Borrow bit
 1 = A carry-out from the 4th low-order bit (for byte sized data) or 8th low-order bit (for word sized data) of the result occurred
 0 = No carry-out from the 4th low-order bit (for byte sized data) or 8th low-order bit (for word sized data) of the result occurred
- bit 7-5 **IPL<2:0>:** CPU Interrupt Priority Level Status bits⁽²⁾
 111 = CPU Interrupt Priority Level is 7 (15), user interrupts disabled
 110 = CPU Interrupt Priority Level is 6 (14)
 101 = CPU Interrupt Priority Level is 5 (13)
 100 = CPU Interrupt Priority Level is 4 (12)
 011 = CPU Interrupt Priority Level is 3 (11)
 010 = CPU Interrupt Priority Level is 2 (10)
 001 = CPU Interrupt Priority Level is 1 (9)
 000 = CPU Interrupt Priority Level is 0 (8)
- bit 4 **RA:** REPEAT Loop Active bit
 1 = REPEAT loop in progress
 0 = REPEAT loop not in progress
- bit 3 **N:** MCU ALU Negative bit
 1 = Result was negative
 0 = Result was non-negative (zero or positive)
- bit 2 **OV:** MCU ALU Overflow bit
 This bit is used for signed arithmetic (2's complement). It indicates an overflow of the magnitude which causes the sign bit to change state.
 1 = Overflow occurred for signed arithmetic (in this arithmetic operation)
 0 = No overflow occurred
- bit 1 **Z:** MCU ALU Zero bit
 1 = An operation which affects the Z bit has set it at some time in the past
 0 = The most recent operation which affects the Z bit has cleared it (i.e., a non-zero result)
- bit 0 **C:** MCU ALU Carry/Borrow bit
 1 = A carry-out from the Most Significant bit (MSb) of the result occurred
 0 = No carry-out from the Most Significant bit of the result occurred

Note 1: The IPL<2:0> bits are concatenated with the IPL<3> bit (CORCON<3>) to form the CPU Interrupt Priority Level. The value in parentheses indicates the IPL if IPL<3> = 1. User interrupts are disabled when IPL<3> = 1.

2: The IPL<2:0> Status bits are read only when NSTDIS = 1 (INTCON1<15>).

PIC24HJXXXGPX06/X08/X10

REGISTER 3-2: CORCON: CORE CONTROL REGISTER

| | | | | | | | |
|--------|-----|-----|-----|-----|-----|-----|-------|
| U-0 | U-0 | U-0 | U-0 | U-0 | U-0 | U-0 | U-0 |
| — | — | — | — | — | — | — | — |
| bit 15 | | | | | | | bit 8 |

| | | | | | | | |
|-------|-----|-----|-----|---------------------|-------|-----|-------|
| U-0 | U-0 | U-0 | U-0 | R/C-0 | R/W-0 | U-0 | U-0 |
| — | — | — | — | IPL3 ⁽¹⁾ | PSV | — | — |
| bit 7 | | | | | | | bit 0 |

| | | | |
|---------------------|----------------------|------------------------------------|------------------|
| Legend: | C = Clear only bit | | |
| R = Readable bit | W = Writable bit | -n = Value at POR | '1' = Bit is set |
| 0' = Bit is cleared | 'x' = Bit is unknown | U = Unimplemented bit, read as '0' | |

- bit 15-4 **Unimplemented:** Read as '0'
- bit 3 **IPL3:** CPU Interrupt Priority Level Status bit 3⁽¹⁾
 - 1 = CPU interrupt priority level is greater than 7
 - 0 = CPU interrupt priority level is 7 or less
- bit 2 **PSV:** Program Space Visibility in Data Space Enable bit
 - 1 = Program space visible in data space
 - 0 = Program space not visible in data space
- bit 1-0 **Unimplemented:** Read as '0'

Note 1: The IPL3 bit is concatenated with the IPL<2:0> bits (SR<7:5>) to form the CPU interrupt priority level.