



Chipsmall Limited consists of a professional team with an average of over 10 year of expertise in the distribution of electronic components. Based in Hongkong, we have already established firm and mutual-benefit business relationships with customers from,Europe,America and south Asia,supplying obsolete and hard-to-find components to meet their specific needs.

With the principle of “Quality Parts,Customers Priority,Honest Operation,and Considerate Service”,our business mainly focus on the distribution of electronic components. Line cards we deal with include Microchip,ALPS,ROHM,Xilinx,Pulse,ON,Everlight and Freescale. Main products comprise IC,Modules,Potentiometer,IC Socket,Relay,Connector.Our parts cover such applications as commercial,industrial, and automotives areas.

We are looking forward to setting up business relationship with you and hope to provide you with the best service and solution. Let us make a better world for our industry!



Contact us

Tel: +86-755-8981 8866 Fax: +86-755-8427 6832

Email & Skype: info@chipsmall.com Web: www.chipsmall.com

Address: A1208, Overseas Decoration Building, #122 Zhenhua RD., Futian, Shenzhen, China



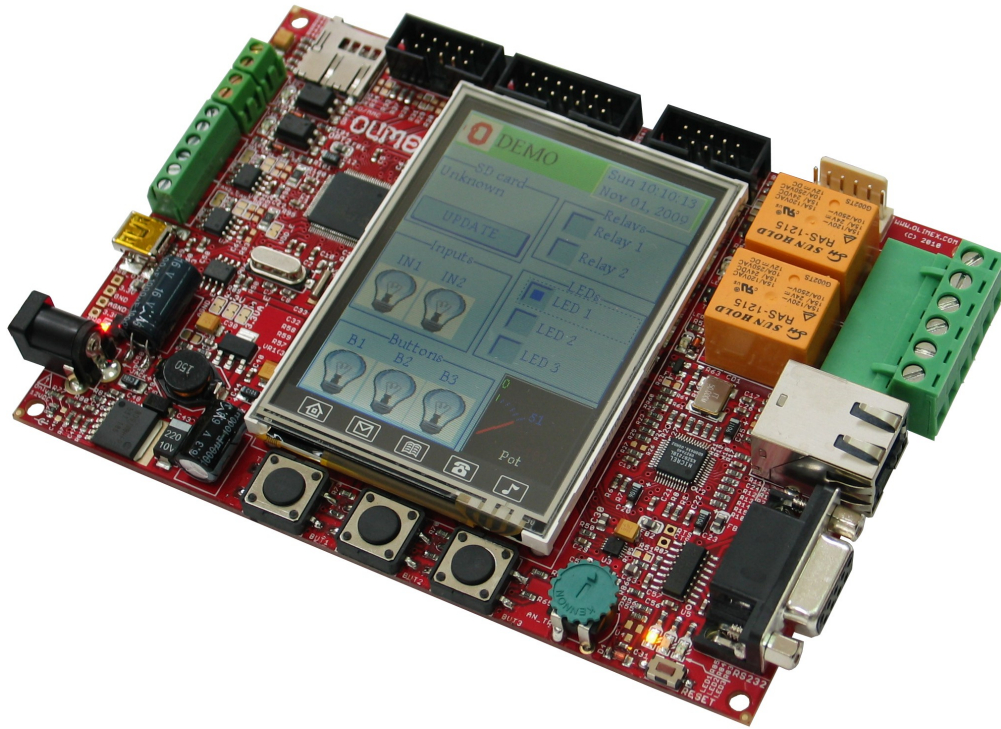

PIC32-MAXI-WEB

General purpose development board

USER'S MANUAL

Document revision C, October 2015
Designed by OLIMEX Ltd, 2013



All boards produced by Olimex LTD are ROHS compliant

DISCLAIMER

© 2015 Olimex Ltd. Olimex®, logo and combinations thereof, are registered trademarks of Olimex Ltd. Other product names may be trademarks of others and the rights belong to their respective owners.

The information in this document is provided in connection with Olimex products. No license, express or implied or otherwise, to any intellectual property right is granted by this document or in connection with the sale of Olimex products.

This hardware design of PIC32-MAXI-WEB is neither public nor open-source. Any copying of the product would result in copyright infringement.

The software is released under the terms that are detailed in the agreement page, that pops-up when you attempt to download a demo software archive.

It is possible that the pictures in this manual differ from the latest revision of the board.

The product described in this document is subject to continuous development and improvements. All particulars of the product and its use contained in this document are given by OLIMEX in good faith. However all warranties implied or expressed including but not limited to implied warranties of merchantability or fitness for purpose are excluded. This document is intended only to assist the reader in the use of the product. OLIMEX Ltd. shall not be liable for any loss or damage arising from the use of any information in this document or any error or omission in such information or any incorrect use of the product.

This evaluation board/kit is intended for use for engineering development, demonstration, or evaluation purposes only and is not considered by OLIMEX to be a finished end-product fit for general consumer use. Persons handling the product must have electronics training and observe good engineering practice standards. As such, the goods being provided are not intended to be complete in terms of required design-, marketing-, and/or manufacturing-related protective considerations, including product safety and environmental measures typically found in end products that incorporate such semiconductor components or circuit boards.

Olimex currently deals with a variety of customers for products, and therefore our arrangement with the user is not exclusive. Olimex assumes no liability for applications assistance, customer product design, software performance, or infringement of patents or services described herein.

THERE IS NO WARRANTY FOR THE DESIGN MATERIALS AND THE COMPONENTS USED TO CREATE PIC32-MAXI-WEB. THEY ARE CONSIDERED SUITABLE ONLY FOR PIC32-MAXI-WEB.

Table of Contents

<u>DISCLAIMER.....</u>	<u>2</u>
<u>1. INTRODUCTION.....</u>	<u>4</u>
1.1 BOARD FEATURES.....	4
1.2 ELECTROSTATIC WARNING:.....	4
1.3 BOARD USE REQUIREMENTS:.....	4
1.4 BOARD LAYOUT.....	5
<u>2. MICROCONTROLLER DETAILS.....</u>	<u>6</u>
2.1 FEATURES.....	6
2.2 BLOCK DIAGRAM.....	8
2.3 MEMORY MAP.....	9
<u>3. BOARD SCHEMATIC AND DIMENSIONS.....</u>	<u>10</u>
3.1 SCHEMATIC.....	10
3.2 PHYSICAL DIMENSIONS.....	12
<u>4. CONTROL CIRCUITRY.....</u>	<u>13</u>
4.1 POWER SUPPLY CIRCUIT.....	13
4.2 RESET CIRCUIT.....	13
4.3 CLOCK CIRCUIT.....	13
<u>5. JUMPERS, CONNECTORS AND INTERFACES.....</u>	<u>14</u>
5.1 JUMPER DESCRIPTION.....	14
5.2 INPUT/OUTPUT.....	14
5.3 EXTERNAL CONNECTOR DESCRIPTION.....	15
5.3.1 PWR JACK.....	15
5.3.2 ICSP CONNECTOR.....	15
5.3.3 RS232/UART.....	16
5.3.6 CAN1 AND CAN2.....	17
5.3.7 JTAG.....	17
5.3.8 UEXT1.....	18
5.3.9 UEXT2.....	18
5.3.10 MICROSD CARD.....	19
<u>6. AVAILABLE DEMO SOFTWARE.....</u>	<u>20</u>
<u>7. REVISION AND ORDERING INFORMATION.....</u>	<u>21</u>
7.1 DOCUMENT REVISION.....	21
7.2 BOARD REVISION.....	21
<u>8. WARRANTY AND SUPPORT.....</u>	<u>22</u>

1. INTRODUCTION

This board features a PIC32 processor with embedded 100Mbit Ethernet module which allows you to easily develop network applications. It has everything you would normally need for such applications: power relays which you can command through a web interface, a large 240×320 TFT LCD with touchscreen support (that allows the development of complex graphical user interface applications), digital opto-isolated inputs, trimmer potentiometer, accelerometer with integrated temperature sensor, two CAN interface channels, RS232 interface, USB On-The-Go and micro SD card slot to store large amounts of data. With this board you can easily automate your home and then control and monitor it from any point in the world via Internet. An extension connector is available so you can connect custom made hardware to the board. The PIC32MX795F512L has 512K Flash memory (plus an additional 12 KB of Boot Flash).

1.1 BOARD FEATURES

The notable board features are listed below:

- PIC32MX795F512L high-performance, USB, CAN and Ethernet 32-bit Flash microcontroller
- TFT LCD 320×240 65k colors with resistive touchscreen
- Debug interface – JTAG and ICSP
- RESET circuit
- Reset button
- Two opto-isolated digital inputs with indicator LEDs
- Two CAN interfaces
- 100Mbit Ethernet interface
- Two UEXT connectors to connect to other Olimex boards
- Accelerometer with integrated temperature sensor
- MicroSD card holder
- Two relays 10A/250VAC with indicator LEDs
- USB On-The-Go
- RS232 interface
- Trimmer connected to analog input
- Three user LEDs
- Stand-alone power LED
- Three user buttons
- 3.3V voltage regulator
- Dimensions (140×100) mm (5.51×3.94)"

1.2 ELECTROSTATIC WARNING:

The PIC32-MAXI-WEB board is shipped in protective anti-static packaging. The board must not be subject to high electrostatic potentials. General practice for working with static sensitive devices should be applied when working with this board.

1.3 BOARD USE REQUIREMENTS:

Cables: the board needs external power supply cable and mini ICSP cable (connected to the respective debugger) in order to test basic functionality. Depending on the peripherals used you may also need and Ethernet RJ45 terminated cable, 9pin RS232 cable, miniUSB cable.

Hardware: The board requires +12V regulated power supply.

!!! Please note that the PIC32 processor on this board is not supported by the once famous ICD2 programmer/debugger and derivatives. You would need a newer debugger/programmer. Please ensure your programmer/debugger is compatible with PIC32 microcontrollers.

1.4 BOARD LAYOUT

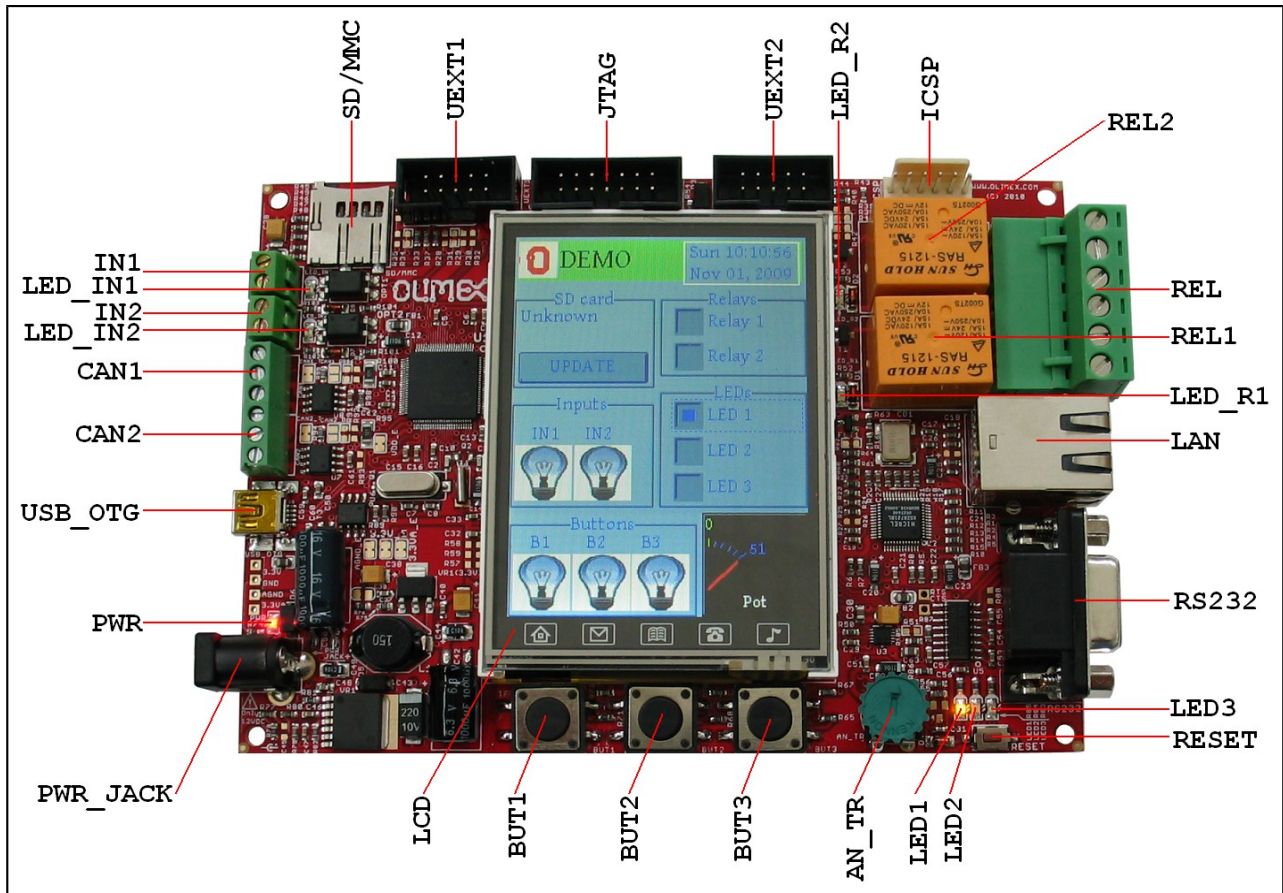

2. MICROCONTROLLER DETAILS

Some of the details about the main microcontroller in PIC32-MAXI-WEB (PIC32MX795F512L) microcontroller are mentioned in this chapter. It is highly recommended to refer to the original datasheet which might be downloaded from the official Microchip web-side.

2.1 FEATURES

PIC32-MAXI-WEB board uses MCU PIC32MX795F512L from Microchip Technology that packs the following features:

High-Performance 32-bit RISC CPU:

- MIPS32® M4K® 32-bit core with 5-stage pipeline
- 80 MHz maximum frequency
- 1.56 DMIPS/MHz (Dhrystone 2.1) performance at zero Wait state Flash access
- Single-cycle multiply and high-performance divide unit
- MIPS16e™ mode for up to 40% smaller code size
- Two sets of 32 core register files (32-bit) to reduce interrupt latency
- Prefetch Cache module to speed execution from Flash

Microcontroller Features:

- Operating voltage range of 2.3V to 3.6V
- 512K Flash memory (plus an additional 12 KB of Boot Flash)
- 128K SRAM memory
- Pin-compatible with most PIC24/dsPIC® DSC devices
- Multiple power management modes
- Multiple interrupt vectors with individually programmable priority
- Fail-Safe Clock Monitor mode
- Configurable Watchdog Timer with on-chip Low-Power RC oscillator for reliable operation

Peripheral Features:

- Atomic SET, CLEAR and INVERT operation on select peripheral registers
- 8-channels of hardware DMA with automatic data size detection
- USB 2.0-compliant full-speed device and On-The-Go (OTG) controller:
 - Dedicated DMA channels
- 10/100 Mbps Ethernet MAC with MII and RMII interface:
 - Dedicated DMA channels
- CAN module:
 - 2.0B Active with DeviceNet™ addressing support
 - Dedicated DMA channels
- 3 MHz to 25 MHz crystal oscillator
- Internal 8 MHz and 32 kHz oscillators
- Six UART modules with:
 - RS-232, RS-485 and LIN 1.2 support
 - IrDA® with on-chip hardware encoder and decoder
- Four SPI modules
- Five I2C™ modules
- Separate PLLs for CPU and USB clocks
- Parallel Master and Slave Port (PMP/PSP) with 8-bit and 16-bit data, and up to 16 address

lines

- Hardware Real-Time Clock and Calendar (RTCC)
- Five 16-bit Timers/Counters (two 16-bit pairs combine to create two 32-bit timers)
- Five Capture inputs
- Five Compare/PWM outputs
- Five external interrupt pins
- High-speed I/O pins capable of toggling at up to 80 MHz
- High-current sink/source (18 mA/18 mA) on all I/O pins
- Configurable open-drain output on digital I/O pins

Debug Features:

- Two programming and debugging Interfaces:
 - 2-wire interface with unintrusive access and real-time data exchange with application
 - 4-wire MIPS® standard enhanced Joint Test Action Group (JTAG) interface
- Unintrusive hardware-based instruction trace
- IEEE Standard 1149.2 compatible (JTAG) boundary scan

Analog Features:

- 16-channel, 10-bit Analog-to-Digital Converter:
 - 1 Msps conversion rate
 - Conversion available during Sleep and Idle
- Two Analog Comparators
- 5V tolerant input pins (digital pins only)

2.2 BLOCK DIAGRAM

A block diagram with main functional parts of the microcontroller as seen in the official Microchip documentation.

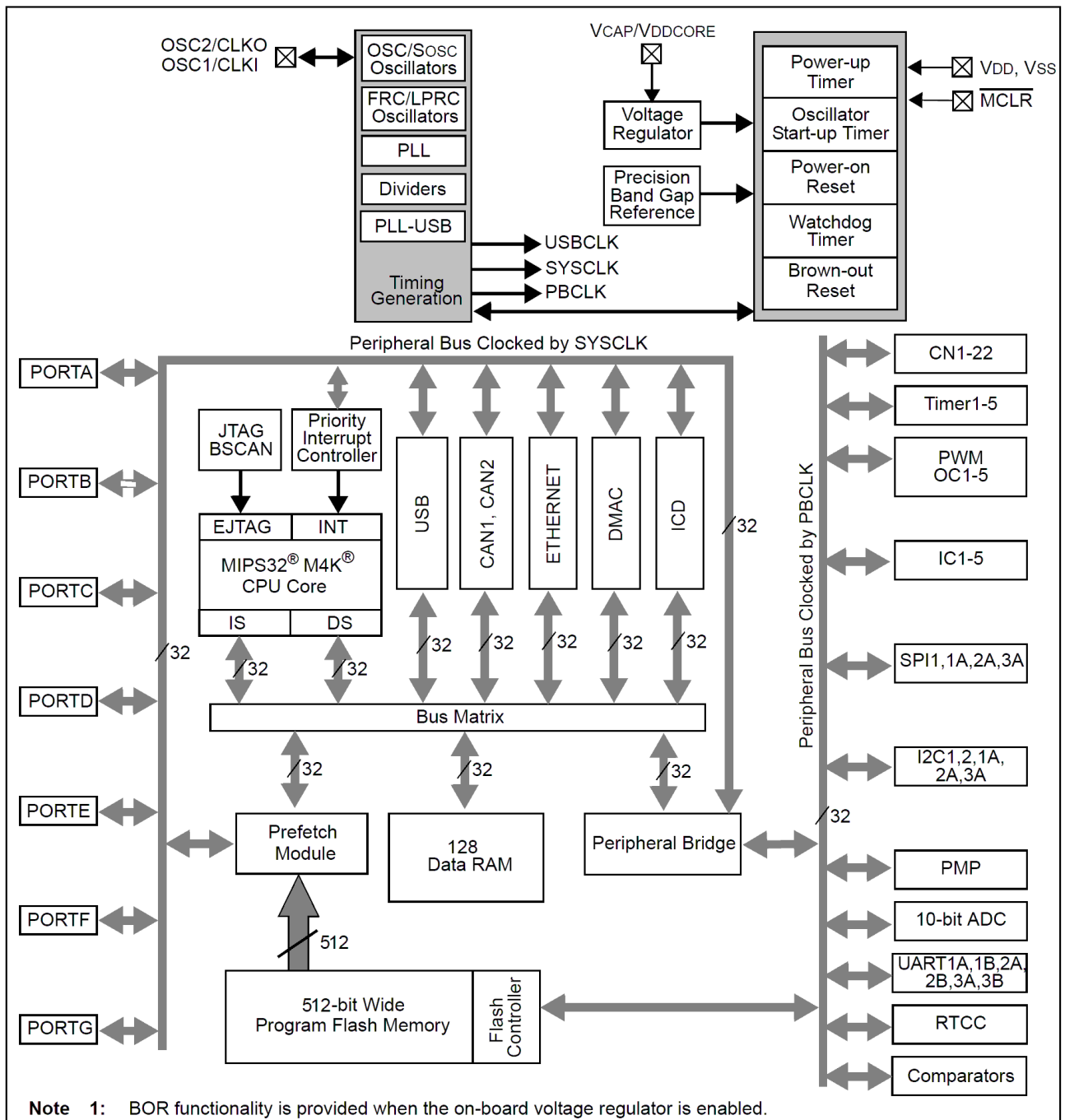

2.3 MEMORY MAP

The microcontroller's memory regions as seen in the official Microchip documentation.

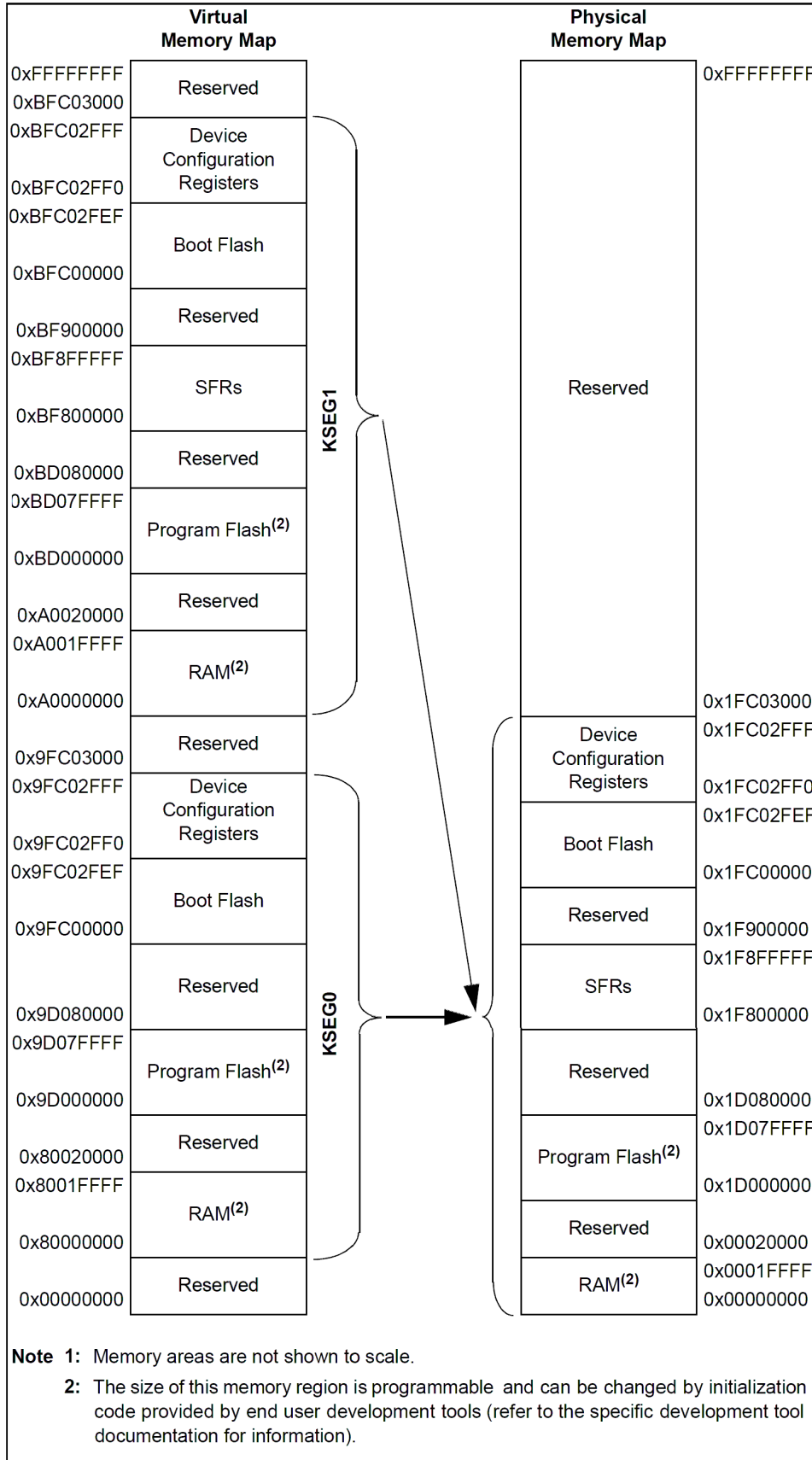

3 BOARD SCHEMATIC AND DIMENSIONS

In this chapter you may find information about the schematics describing logically and physically PIC32-MAXI-WEB.

3.1 SCHEMATIC

The schematic of PIC32-MAXI-WEB is available for reference on the next page.

Only the board schematic is available to the customer. It is available only as a stand-alone PDF document and as a reference image on. The board design files are kept private.

If you are looking for a schematic of an older revision of the board and it isn't available at our web site you may request it by the support e-mail.

PIC32-MAXI-WEB, board revision A:

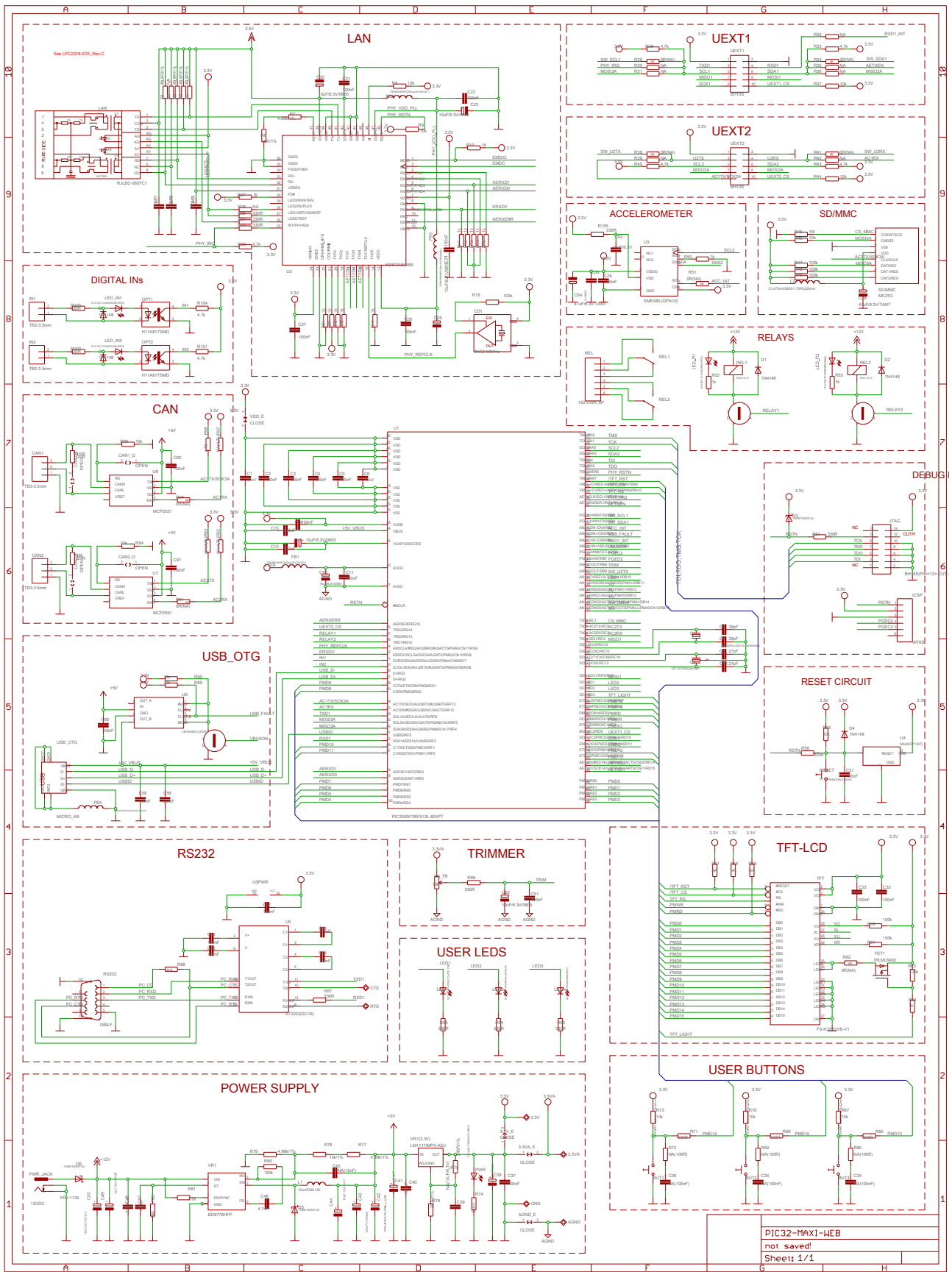

3.2 PHYSICAL DIMENSIONS

Note that all dimensions are in millimeters.

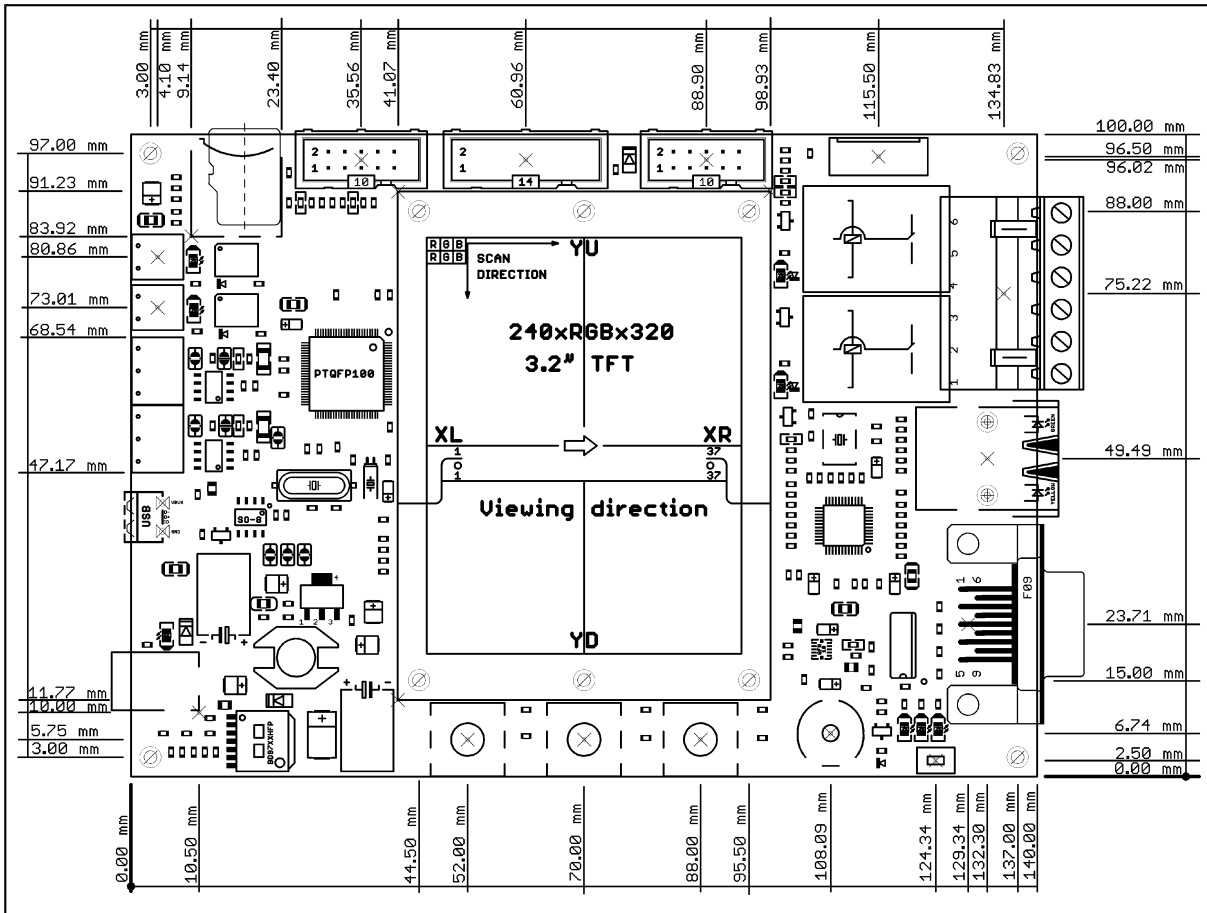

4. CONTROL CIRCUITRY

4.1 POWER SUPPLY CIRCUIT

PIC32-MAXI-WEB can be power only from power connector PWR_JACK, where only 12 VDC external voltage source has to be applied.

The board power consumption is about 300mA with all peripherals and MCU running at full speed, relays and LEDs on and established Ethernet connection.

4.2 RESET CIRCUIT

PIC32-MAXI-WEB reset circuit is made of D4 (1N4148), RC group R55 – 10k and C31 – 100nF. Serial resistor R56 – 330Ω is used to prevent fast C31 charge and discharge when PIC32MX795F512L is being programmed.

Manual reset is possible by the RESET button.

4.3 CLOCK CIRCUIT

Quartz crystal Q1 8MHz is connected to PIC32MX795F512L pins 63 (OSC1/CLKI/RC12) and 64 (OSC2/CLKO/RC15).

Quartz crystal Q2 32.768 KHz is connected to PIC32MX795F512L pins 73 (SOSCI/CN1/RC13) and 74 (SOSCO/T1CK/CN0/RC14).

5. JUMPERS, CONNECTORS AND INTERFACES

In this chapter you will find the description of the jumpers and what signals might be found on the different connectors.

5.1 JUMPER DESCRIPTION



3.3V_E – Enables 3.3V supply for PIC32MX795F512L and all other devices.
Default state closed (shorted).



3.3VA_E – Enables 3.3V positive supply for analog modules.
Default state is closed (shorted).



VDD_E – Enables PIC32MX795F512L's 3.3V power supply.
Default state is closed (shorted).



AGND_E – Enables the analog ground.
Default state is closed (shorted).



CAN1_T – This jumper assures correct work of the CAN1. At each end of the bus it should be closed. This means that if you have only two devices with CAN, the jumpers of both devices should be closed. If you have more than two devices, only the two end devices should be closed.

Default state is closed (shorted).



CAN1_D – CAN Disable. If this jumper is closed, the CAN1 is disabled.
Default state is open (not shorted).



CAN2_T – This jumper assures correct work of the CAN2. At each end of the bus it should be closed. This means that if you have only two devices with CAN, the jumpers of both devices should be closed. If you have more than two devices, only the two end devices should be closed.

Default state is closed (shorted).



CAN2_D – CAN Disable. If this jumper is closed, the CAN2 is disabled.
Default state is open (not shorted).

5.2 INPUT/OUTPUT

User button with name BUT1 – connected to PIC32MX795F512L pin 83 (ETXEN/PMD14/CN15/RD6).

User button with name BUT2 – connected to PIC32MX795F512L pin 84 (ETXCLK/PMD15/CN16/RD7).

User button with name BUT3 – connected to PIC32MX795F512L pin 80 (ETXD3/PMD13/CN19/RD13).

Reset button with name RESET – connected to PIC32MX460F512L pin 13 (#MCLR).

One analog trimmer with name AN_TR – connected to PIC32MX795F512L pin 32 (AN8/C1OUT/RB8).

Status Led (yellow) with name LED1 – connected to PIC32MX795F512L pin 34 (AN10/CVREFOUT/PMA13/RB10).

Status Led (green) with name LED2 – connected to PIC32MX795F512L pin 76 (OC2/RD1).
Status Led (red) with name LED3 – connected to PIC32MX795F512L pin 77 (OC3/RD2).

Two opto-isolated digital inputs IN1 and IN2.

Two red LEDs – LED_IN1 and LED_IN2 for every digital input.

Two red LEDs – LED_R1, LED_R2 – for the relays.

Power supply red LED with name PWR – indicates that 3.3V power supply is available.

TFT LCD Display – FS-K320QVB-V1

5.3 EXTERNAL CONNECTOR DESCRIPTION

5.3.1 PWR_JACK

The power jack is used to power the board. Exactly 12V of voltage should be provided. The current required depends on the peripherals used but generally your source should be capable to provide at least 350mA.

The power jack is like the ones we use on all Olimex boards → YDJ-1134 (2mm in diameter front hole).

If your power adapter doesn't have the same jack you would need to adapt it. Make sure that you carefully follow the pin assignment.

Pin #	Signal name
1	Power input
2	GND

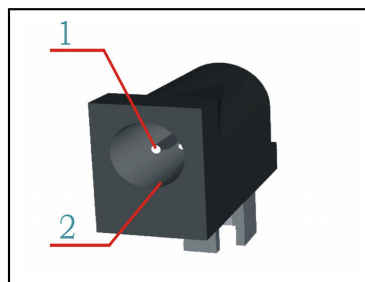

5.3.2 ICSP CONNECTOR

The ICSP connector is used for serial programming. It is the place where most common PIC32-compatible programmers and debuggers are connected. The pins have 0.1" step. If your programmer/debugger has only the smaller 0.05" connector you might need an adapter or you should use jumper wires.

Pin #	Signal name
1	RSTN
2	3.3V
3	GND
4	PGED2
5	PGEC2
6	NC

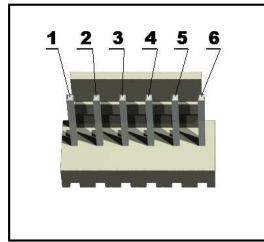

PGED2 conducts I/O operations for the “Program Data” signal. Serial data for programming. **PGEC2** serves only as input for the “Program Clock” signal. Clock used for transferring the serial data (output from ICSP, input for the MCU).

5.3.3 RS232/UART

Pin #	Signal name
1	PC_CD
2	PC_RXD
3	PC_TXD
4	NC
5	GND
6	NC
7	PC_RTS
8	PC_CTS
9	NC

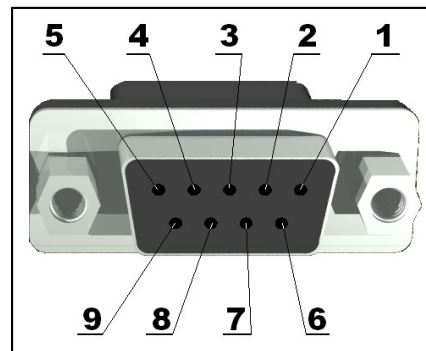

TXD is an output. It is the “Transmit Data” signal which is the asynchronous serial data output (RS232) for the shift register on the UART controller.

RXD is an input. It is the “Receive Data” signal which is the asynchronous serial data input (RS232) for the shift register on the UART controller.

The demo software uses RS232 so it would display your IP address on a PC terminal program (at 115200 baud) when the board is connected to a PC and has a valid Ethernet source connected.

5.3.4 USB_OTG

Pin #	Signal name
1	+5V_VBUS
2	USB_D-
3	USB_D+
4	USBID
5	GND

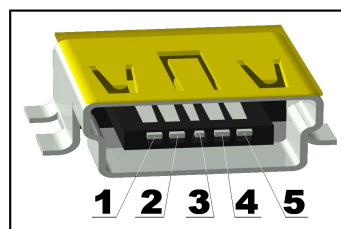

5.3.5 ETHERNET

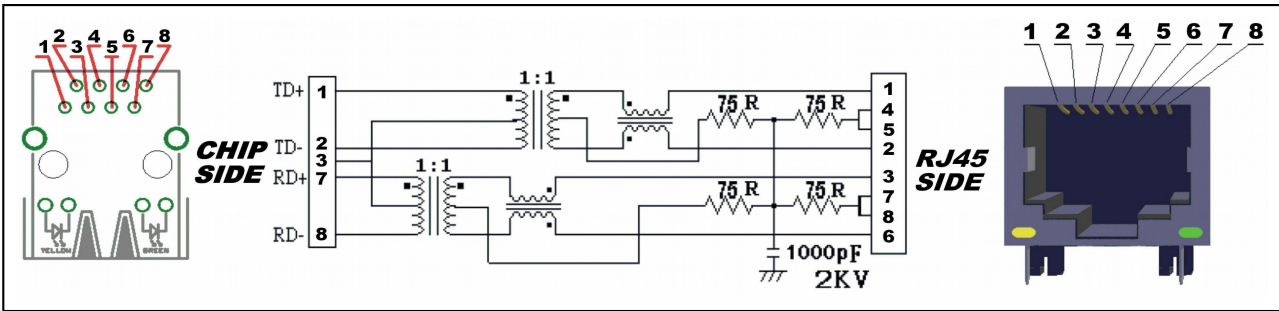

Pin #	Signal name(chip side)	Pin #	Signal name(chip side)
1	TX+	5	Not Connected (NC)
2	TX-	6	Not Connected (NC)
3	VCC/2 (2.5V)	7	RX+
4	Not Connected (NC)	8	RX-

LED	Color	Usage
Left	Yellow	100Mbits/s (Half/Full duplex)
Right	Green	Activity

5.3.6 CAN1 AND CAN2

Controller Area Network(CAN) is a standard designed to allow microcontrollers and devices to communicate with each other within a vehicle without a host computer. Both CAN1 and CAN2 connectors follow the same layout.

Pin #	Signal
1	GND
2	CANL
3	CANH

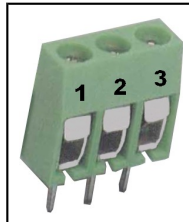

5.3.7 JTAG

The microcontroller has EJTAG support. The EJTAG signals are provided on the 14-pin JTAG connector.

Pin #	Signal name	Pin #	Signal name
1	NC	8	GND
2	GND	9	TCK
3	TDI	10	GND
4	GND	11	RSTN
5	TDO	12	CUT
6	GND	13	NC
7	TMS	14	3.3v

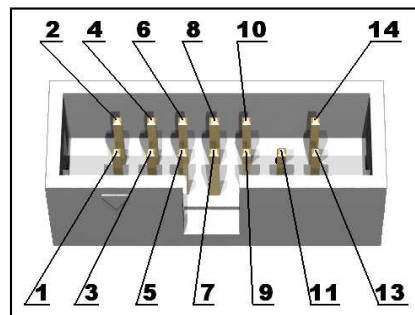

5.3.8 UEXT1

The 10-pin UEXT connectors are typically mounted on Olimex boards. They pack three common interfaces in a single connector – UART, I2C and SPI. You can use the UEXT connector to access this interfaces easier (via jumper wires, for example).

You can also connect expansion modules to the UEXT connectors. More on UEXT might be found here: <https://www.olimex.com/Products/Modules/UEXT/>

Pin #	Signal name
1	3.3 V
2	GND
3	TXD1
4	RXD1
5	SCL1
6	SDA1
7	MISO1
8	MOSI1
9	SCK1
10	UEXT1_CS

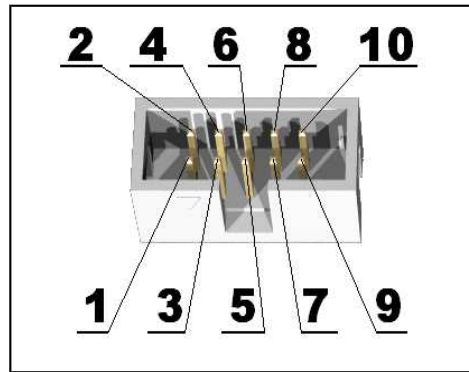

5.3.9 UEXT2

UEXT2 features other UART, I2C and SPI signals. However there is multiplexing on some of the lines which might cause problems if you are trying to use the line on both places.

The I2C data lines (SCL2, SDA2) are used for the built-in the board accelerometer. The SPI clock signal AC1TX/SCK3A is used by the SD card connector.

Pin #	Signal name
1	3.3 V
2	GND
3	U2TX
4	U2RX
5	SCL2
6	SDA2
7	MISO3A
8	MOSI3A
9	AC1TX/SCK3A
10	UEXT2_CS

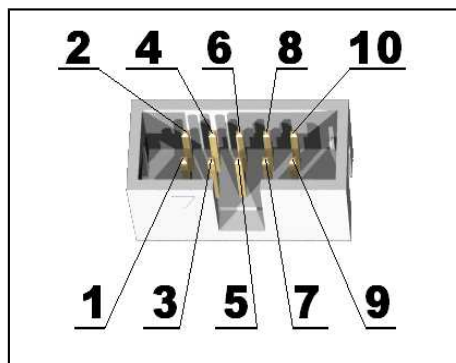

5.3.10 MICROSD CARD

Pin #	Signal name
1	MCIDAT2
2	CS_MMC
3	MOSI3A
4	VDD (3.3 V)
5	AC1TX/SCK3A
6	GND
7	MISO3A
8	MCIDAT1
9	Not Connected
10	Not Connected
11	Not Connected
12	Not Connected

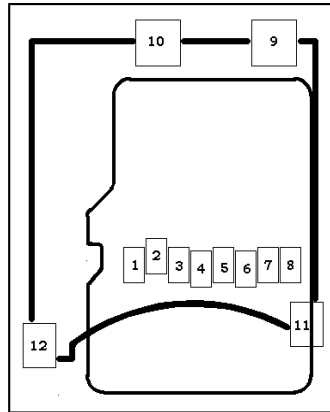

6. AVAILABLE DEMO SOFTWARE

To compile the demo you would need the following tools: MPLAB IDE v8.91 or MPLABX 1.80, Compiler: XC32 v1.21.

The demo demonstrates the functionality of the various peripherals of the board including user input, serial communication, the implementation of Graphical User Interface (GUI) and network connectivity

The demo is built upon the Microchip Solutions library (released on 22 august 2012) including freely distributed support libraries:

- Microchip Graphics Library v3.06
- Microchip TCP/IP Stack Library v5.42
- Microchip MDD File System Library 1.4.0 (FAT, FAT32 file systems)
- Microchip USB support source files

FreeRTOS was used to make all tasks run virtually simultaneously. FreeRTOS is a freely distributed RTOS with excellent support and online documentation. Version used is v7.3.0. MPLAB has support for FreeRTOS (Tools/RTOS viewer).

You could find demo software for PIC32-MAXI-WEB board at the board's web page. It is recommended to refer to the "README.txt" file inside the demo archive.

Direct link to PIC32-MAXI-WEB's web-page:

<https://www.olimex.com/Products/PIC/Development/PIC32-MAXI-WEB/>

7. REVISION AND ORDERING INFORMATION

PIC32-MAXI-WEB – fully assembled and tested

How to purchase?

You can purchase directly from our online shop or from any of our distributors. Note that usually it is faster and cheaper to purchase Olimex products from our distributors. List of confirmed Olimex LTD distributors and resellers: <https://www.olimex.com/Distributors>.

Please visit <https://www.olimex.com/> for more info.

7.1 DOCUMENT REVISION

Revision, date	Changes	Modified page
A, 30.08.13	Initial manual release	All
B, 03.12.13	Document remake	All
C, 30.10.15	Fixed a number of errors	All

7.2 BOARD REVISION

Remember to check the schematics and the board design files to compare the differences.

Revision	Notable changes
A	Initial release of the board

8. WARRANTY AND SUPPORT

For product support, hardware information and error reports mail to: support@olimex.com. All document or hardware feedback is welcome. Note that we are primarily a hardware company and our software support is limited. Please consider reading the paragraph below about the warranty of Olimex products.

All goods are checked before they are sent out. In the unlikely event that goods are faulty, they must be returned, to OLIMEX at the address listed on your order invoice.

OLIMEX will not accept goods that have clearly been used more than the amount needed to evaluate their functionality.

If the goods are found to be in working condition, and the lack of functionality is a result of lack of knowledge on the customers part, no refund will be made, but the goods will be returned to the user at their expense.

All returns must be authorized by an RMA Number. Email support@olimex.com for authorization number before shipping back any merchandise. Please include your name, phone number and order number in your email request.

Returns for any unaffected development board, programmer, tools, and cables permitted within 7 days from the date of receipt of merchandise. After such time, all sales are considered final.

Returns of incorrect ordered items are allowed subject to a 10% restocking fee. What is unaffected? If you hooked it to power, you affected it. To be clear, this includes items that have been soldered to, or have had their firmware changed. Because of the nature of the products we deal with (prototyping electronic tools) we cannot allow returns of items that have been programmed, powered up, or otherwise changed post shipment from our warehouse.

All returned merchandise must be in its original mint and clean condition. Returns on damaged, scratched, programmed, burnt, or otherwise 'played with' merchandise will not be accepted.

All returns must include all the factory accessories which come with the item. This includes any In-Circuit-Serial-Programming cables, anti-static packing, boxes, etc.

With your return, enclose your PO#. Also include a brief letter of explanation of why the merchandise is being returned and state your request for either a refund or an exchange. Include the authorization number on this letter, and on the outside of the shipping box.

Please note: It is your responsibility to ensure that returned goods reach us. Please use a reliable form of shipping. If we do not receive your package we will not be held liable.

Shipping and handling charges are not refundable. We are not responsible for any shipping charges of merchandise being returned to us or returning working items to you.

The full text might be found at <https://www.olimex.com/wiki/GTC#Warranty> for future reference.