



Chipsmall Limited consists of a professional team with an average of over 10 year of expertise in the distribution of electronic components. Based in Hongkong, we have already established firm and mutual-benefit business relationships with customers from,Europe,America and south Asia,supplying obsolete and hard-to-find components to meet their specific needs.

With the principle of “Quality Parts,Customers Priority,Honest Operation,and Considerate Service”,our business mainly focus on the distribution of electronic components. Line cards we deal with include Microchip,ALPS,ROHM,Xilinx,Pulse,ON,Everlight and Freescale. Main products comprise IC,Modules,Potentiometer,IC Socket,Relay,Connector.Our parts cover such applications as commercial,industrial, and automotives areas.

We are looking forward to setting up business relationship with you and hope to provide you with the best service and solution. Let us make a better world for our industry!



Contact us

Tel: +86-755-8981 8866 Fax: +86-755-8427 6832

Email & Skype: info@chipsmall.com Web: www.chipsmall.com

Address: A1208, Overseas Decoration Building, #122 Zhenhua RD., Futian, Shenzhen, China



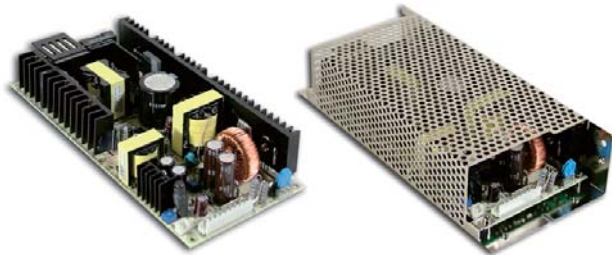

■ Features :

- Universal AC input / Full range
- **Optional L-Bracket and cover**
- Isolated output & GND for CH1,CH2
- Built-in active PFC function, PF>0.92
- Protections:Short circuit / Overload / Over voltage / Over temperature
- Remote control for CH1
- Peak load 170% for CH1 within 10 sec.
- Cooling by free air convection
- 100% full load burn-in test
- 3 years warranty



SPECIFICATION

MODEL	PID-250A		PID-250B		PID-250C		PID-250D			
OUTPUT	OUTPUT NUMBER	CH1	CH2	CH1	CH2	CH1	CH2	CH1	CH2	
	DC VOLTAGE	12V	5V	24V	5V	36V	5V	48V	5V	
	RATED CURRENT	15A(Peak 20A)	5A	9.4A(Peak 16.7A)	5A	6.3A(Peak 11.1A)	5A	4.7A(Peak 8.4A)	5A	
	CURRENT RANGE <small>Note.6</small>	0 ~ 15A (Peak 20A)	0 ~ 5A	0 ~ 9.4A (Peak 16.7A)	0 ~ 5A	0 ~ 6.3A (Peak 11.1A)	0 ~ 5A	0 ~ 4.7A (Peak 8.4A)	0 ~ 5A	
	RATED POWER	205W		250.6W		251.8W		250.6W		
	RIPPLE & NOISE (max.) <small>Note.2</small>	120mVp-p	50mVp-p	150mVp-p	50mVp-p	200mVp-p	50mVp-p	200mVp-p	50mVp-p	
	VOLTAGE ADJ. RANGE	10.8 ~ 13.2V	4.75 ~ 5.25V	21.6 ~ 26.4V	4.75 ~ 5.25V	32.4 ~ 39.6V	4.75 ~ 5.25V	43.2 ~ 52.8V	4.75 ~ 5.25V	
	VOLTAGE TOLERANCE <small>Note.3</small>	±3.0%	±2.0%	±2.0%	±2.0%	±2.0%	±2.0%	±2.0%	±2.0%	
	LINE REGULATION	±0.5%	±0.5%	±0.5%	±0.5%	±0.5%	±0.5%	±0.5%	±0.5%	
	LOAD REGULATION	±1.0%	±2.0%	±1.0%	±2.0%	±1.0%	±2.0%	±1.0%	±2.0%	
SETUP, RISE TIME	250ms, 60ms/115VAC		120ms, 60ms/230VAC							
HOLD UP TIME (Typ.)	30ms at full load									
INPUT	VOLTAGE RANGE <small>Note.5</small>	90 ~ 264VAC		127 ~ 370VDC						
	FREQUENCY RANGE	47 ~ 63Hz								
	POWER FACTOR	PF ≥ 0.92/230VAC		PF ≥ 0.97/115VAC at full load						
	EFFICIENCY(Typ.)	83%		86%		86%		86%		
	AC CURRENT (Typ.)	3A/115VAC		1.5A/230VAC						
	INRUSH CURRENT (Typ.)	COLD START 58A/230VAC								
LEAKAGE CURRENT	<3.5mA / 240VAC									
PROTECTION	OVERLOAD	CH1: 105 ~ 170% rated output power Normally work within 10 sec and then shut down, re-power on to recover Over 180% rated power or short circuit, constant current limiting within 10 sec and then shut down, re-power on to recover CH2: 101 ~ 150% rated output power Protection type : Hiccup mode, recovers automatically after fault condition is removed								
	OVER VOLTAGE	13.8 ~ 16.2V	5.5 ~ 6.75V	27.6 ~ 32.4V	5.5 ~ 6.75V	40 ~ 48V	5.5 ~ 6.75V	54 ~ 64.8V	5.5 ~ 6.75V	
	OVER TEMPERATURE	Shut down o/p voltage(CH1), recovers automatically after temperature goes down								
FUNCTION	REMOTE CONTROL	CN52 : Open=CH1 & CH2 power on ; Short = CH1 power off, CH2 power on; when CH2 is malfunction, CH1 will be shut down								
ENVIRONMENT	WORKING TEMP.	-20 ~ +70°C (Refer to "Derating Curve")								
	WORKING HUMIDITY	20 ~ 90% RH non-condensing								
	STORAGE TEMP., HUMIDITY	-20 ~ +85°C, 10 ~ 95% RH								
	TEMP. COEFFICIENT	±0.05%/°C (0 ~ 50°C)								
	VIBRATION	10 ~ 500Hz, 2G 10min./1cycle, period for 60min each along X, Y, Z axes								
SAFETY & EMC (Note 4)	SAFETY STANDARDS	UL60950-1, TUV EN60950-1, EAC TP TC 004 approved								
	WITHSTAND VOLTAGE	I/P-O/P:3KVAC		I/P-FG:2KVAC		O/P-FG:0.5KVAC				
	ISOLATION RESISTANCE	I/P-O/P, I/P-FG, O/P-FG:100M Ohms / 500VDC / 25°C / 70% RH								
	EMC EMISSION	Compliance to EN55032 (CISPR32) Class B, EN61000-3-2,-3, EAC TP TC 020								
OTHERS	EMC IMMUNITY	Compliance to EN61000-4-2,3,4,5,6,8,11, EN61000-6-2, heavy industry level, criteria A, EAC TP TC 020								
	MTBF	150.4K hrs min.		MIL-HDBK-217F (25°C)						
	DIMENSION	PCB:222*95*40mm (L*W*H) ; with optional CASE:250*105.4*53mm (L*W*H)								
	PACKING	PCB:0.74Kg; 18pcs/14.3Kg/0.88CUFT ; with optional CASE:1.6Kg; 9pcs/15.4Kg/0.61CUFT								

NOTE

1. All parameters NOT specially mentioned are measured at 230VAC input, rated load and 25°C of ambient temperature.
2. Ripple & noise are measured at 20MHz of bandwidth by using a 12" twisted pair-wire terminated with a 0.1uf & 47uf parallel capacitor.
3. Tolerance : includes set up tolerance, line regulation and load regulation.
4. The power supply is considered a component which will be installed into a final equipment. All the EMC tests are been executed by mounting the unit on a 360mm*360mm metal plate with 1mm of thickness. The final equipment must be re-confirmed that it still meets EMC directives. For guidance on how to perform these EMC tests, please refer to "EMI testing of component power supplies." (as available on <http://www.meanwell.com>)
5. Derating may be needed under low input voltage. Please check the derating curve for more details.
6. Peak current should reduce to 150% of rated value if the input voltage <110VAC.
7. Heat Sink HS1,HS2,HS3 can not be shorted.
8. The ambient temperature derating of 3.5°C/1000m with fanless models and of 5°C/1000m with fan models for operating altitude higher than 2000m(6500ft).

Mechanical Specification

Unit:mm

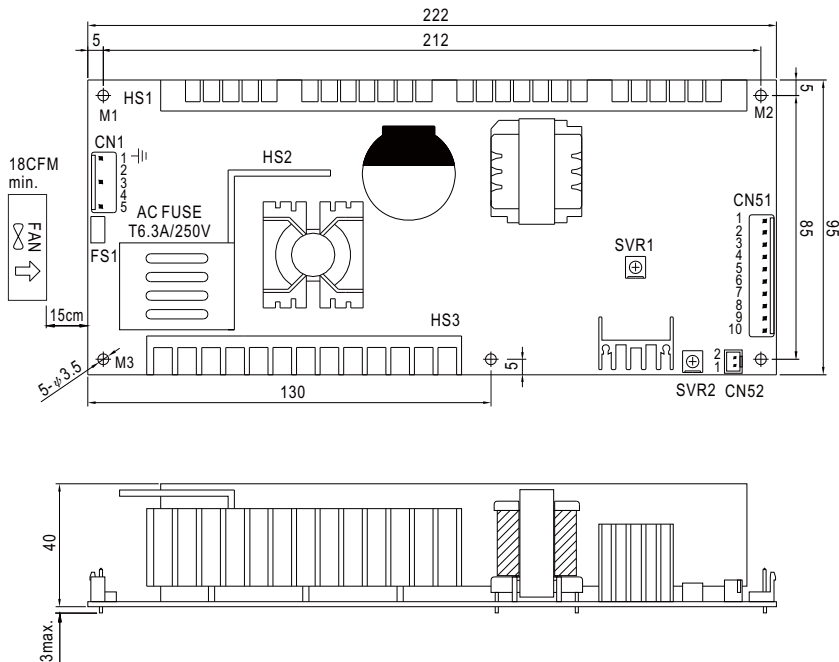

AC Input Connector (CN1) : JST B5P-VH or equivalent

Pin No.	Assignment	Mating Housing	Terminal
1	FG \perp	JST VHR or equivalent	JST SVH-21T-P1.1 or equivalent
2,4	No Pin		
3	AC/N		
5	AC/L		

\perp : Grounding Required

DC Output Connector (CN51) : JST B10P-VH or equivalent

Pin No.	Assignment	Mating Housing	Terminal
1,2,3	COM1	JST VHR or equivalent	JST SVH-21T-P1.1 or equivalent
4,5,6	V1		
7,8	COM2		
9,10	V2		

Remote ON/OFF Connector(CN52):JST B2B-XH or equivalent

Pin No.	Status	Mating Housing	Terminal
PIN1,2 (Short)	V1: OFF V2: ON	JST XHP or equivalent	JST SXH-001T-P0.6 or equivalent
PIN1,2 (Open)	V1: ON V2: ON		

SVR1	For CH1
SVR2	For CH2



- 1.HS1,HS2,HS3 cannot be shorted.
- 2.CN1:Pin1 is safety ground. For better EMC performance,Please secure an electrical connection between M1,M2,M3,and chassis grounding.

Block Diagram

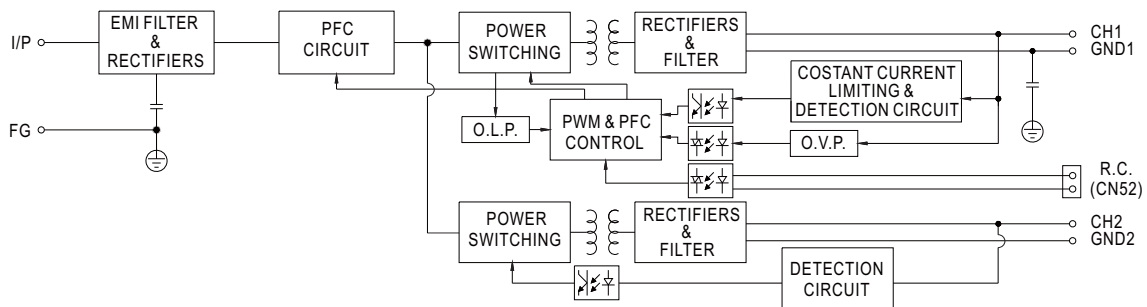

PFC fosc : 100KHz
PWM fosc : 100KHz

Derating Curve

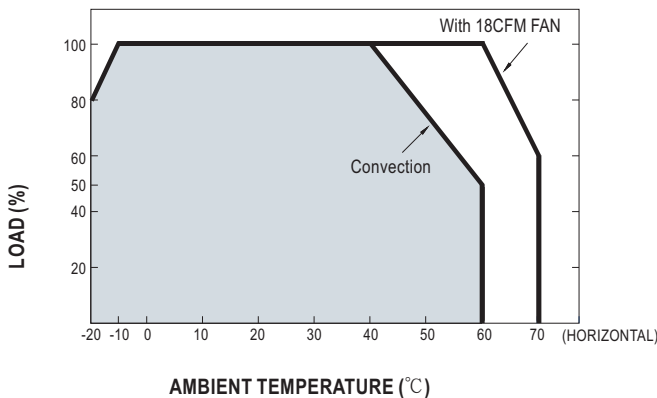

Output Derating VS Input Voltage

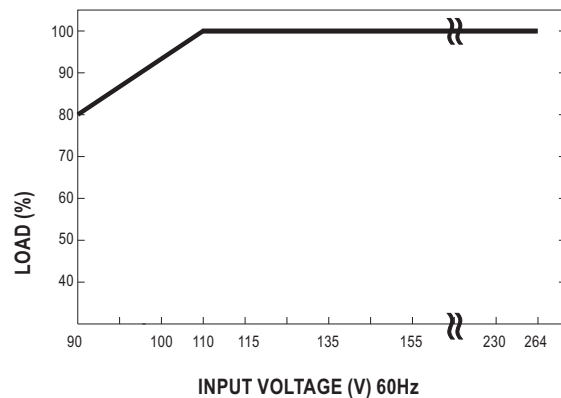

Mechanical Specification

Case No.965A Unit:mm

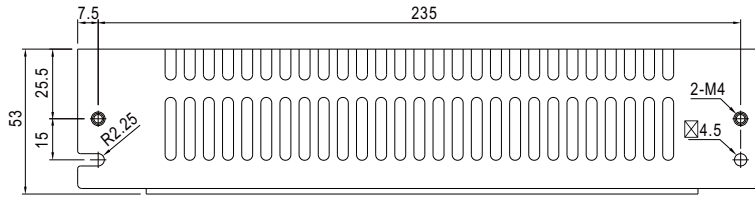

AC Input Connector (CN1) : JST B5P-VH or equivalent

Pin No.	Assignment	Mating Housing	Terminal
1	FG \perp	JST VHR or equivalent	JST SVH-21T-P1.1 or equivalent
2,4	No Pin		
3	AC/N		
5	AC/L		

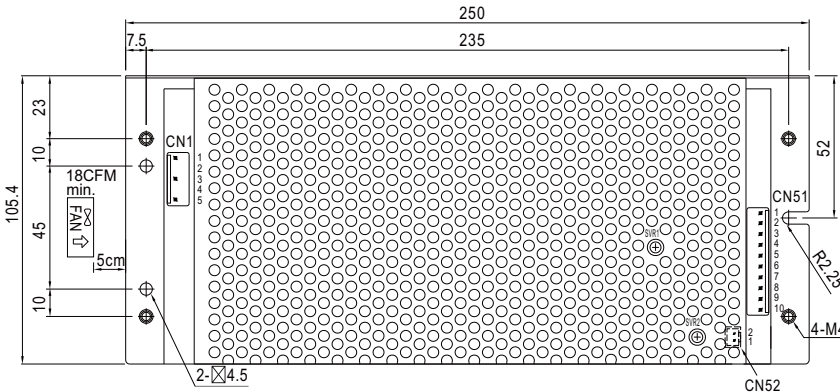

DC Output Connector (CN51) : JST B10P-VH or equivalent

Pin No.	Assignment	Mating Housing	Terminal
1,2,3	COM1	JST VHR or equivalent	JST SVH-21T-P1.1 or equivalent
4,5,6	V1		
7,8	COM2		
9,10	V2		

Remote ON/OFF Connector(CN52):JST B2B-XH or equivalent

Pin No.	Status	Mating Housing	Terminal
PIN1,2 (Short)	V1: OFF V2: ON	JST XHP or equivalent	JST SXH-001T-P0.6 or equivalent
PIN1,2 (Open)	V1: ON V2: ON		

SVR1	For CH1
SVR2	For CH2

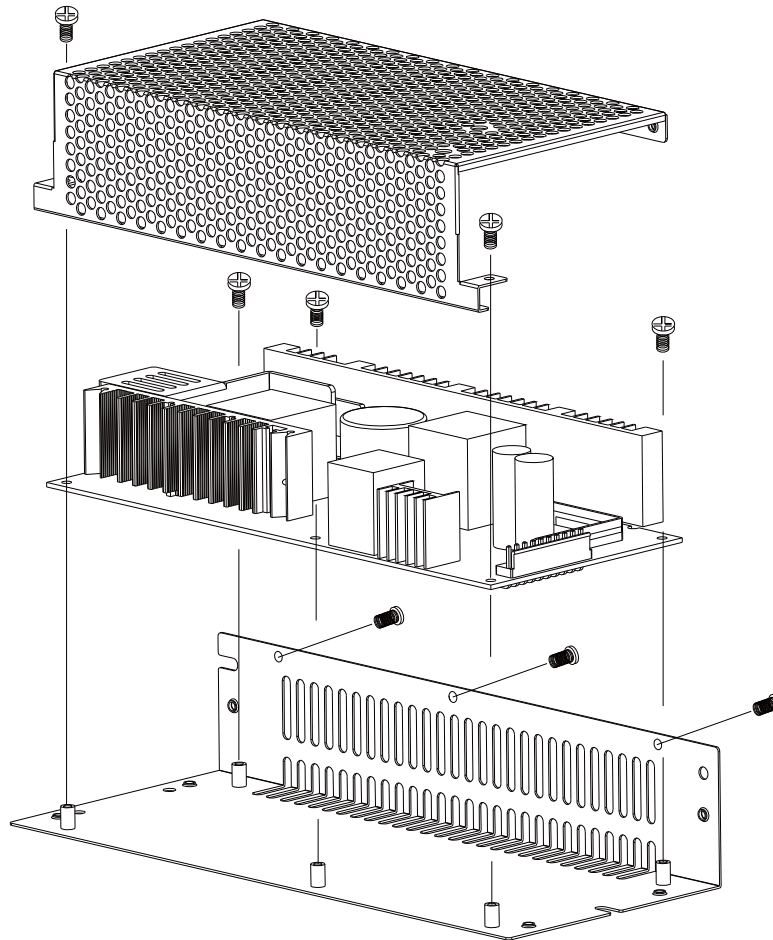

Block Diagram

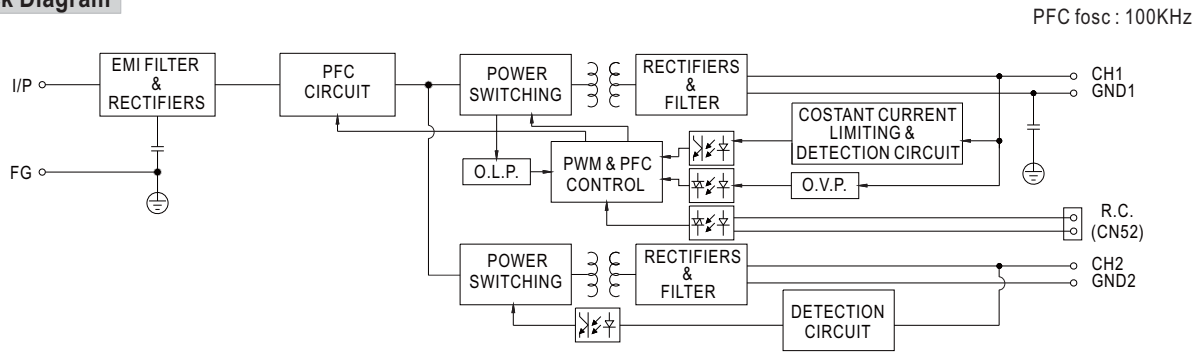

Derating Curve

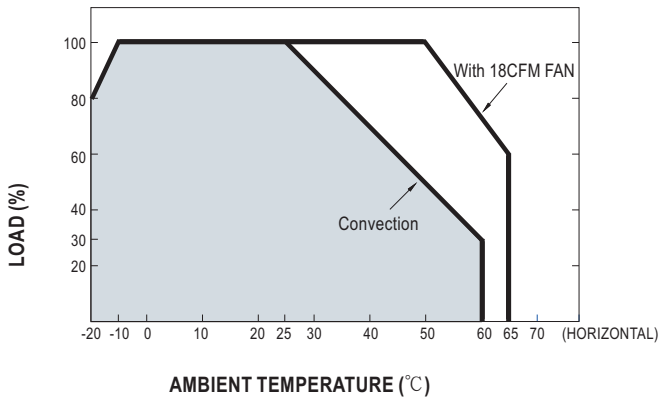

Output Derating VS Input Voltage

