



Chipsmall Limited consists of a professional team with an average of over 10 year of expertise in the distribution of electronic components. Based in Hongkong, we have already established firm and mutual-benefit business relationships with customers from,Europe,America and south Asia,supplying obsolete and hard-to-find components to meet their specific needs.

With the principle of “Quality Parts,Customers Priority,Honest Operation,and Considerate Service”,our business mainly focus on the distribution of electronic components. Line cards we deal with include Microchip,ALPS,ROHM,Xilinx,Pulse,ON,Everlight and Freescale. Main products comprise IC,Modules,Potentiometer,IC Socket,Relay,Connector.Our parts cover such applications as commercial,industrial, and automotives areas.

We are looking forward to setting up business relationship with you and hope to provide you with the best service and solution. Let us make a better world for our industry!



Contact us

Tel: +86-755-8981 8866 Fax: +86-755-8427 6832

Email & Skype: info@chipsmall.com Web: www.chipsmall.com

Address: A1208, Overseas Decoration Building, #122 Zhenhua RD., Futian, Shenzhen, China



SIP PIN **SP-1A**

SP-1A-R1000 1000 PIECE ROLL

Now available in rolls of 1000 pieces these are the same SIP Pins used on our breadboard and adaptor products. When placed on boards of .031 in. thickness spring tension holds the pin in position for soldering. The entire pin and board pads are then fluxed and soldered by wave or dip method. For wave soldering fixtures may be needed to hold the assemblies in the proper position. After soldering the header is removed by shearing with lead shears or other suitable methods.

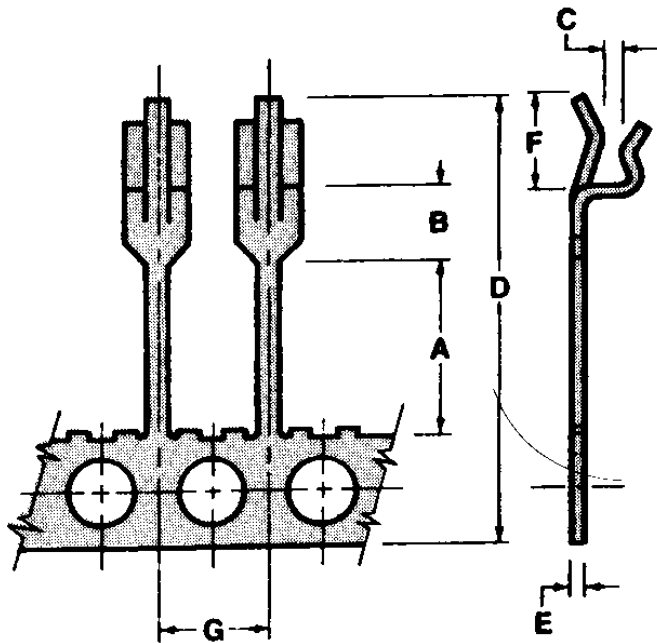

DIM	in.	mm
A	.162	4.11
B	.068	1.72
C	.024	.609
D	.410	10.41
E	.010	.254
F	.080	2.03
G	.100	2.54

SPROCKET HOLES: .062
 NOTE: ACCUMULATION OVER 10 LEADS (G) NOT TO EXCEED .010

TOLERANCES / DECIMAL	
XX	+/- .01
XXX	+/- .005
XXXX	+/- .0002

MATERIAL: Pre-Tin Plated Half Hard Phosphor Bronze .010 In. Thick RoHS Compliant
 PACKAGE: Rolls of 1000 pieces with paper interleaf.

Copyright 2008 by Capital Advanced Technologies, Inc. All Rights Reserved. Availability, specifications, and prices are subject to change without notice. All information given is believed to be accurate but is not guaranteed. The user of information given or products represented by such information is responsible for determining the suitability of said information or products for a given purpose. No permission is granted or implied regarding the use of intellectual property or patents owned by Capital Advanced Technologies, Inc. or others by the provision of information or products herein.

CAPITAL ADVANCED TECHNOLOGIES, INC.
Carol Stream, Illinois. USA
 CapitalAdvanced.Com
 Phone 630-690-1696 Fax 630-690-2498