



Chipsmall Limited consists of a professional team with an average of over 10 year of expertise in the distribution of electronic components. Based in Hongkong, we have already established firm and mutual-benefit business relationships with customers from,Europe,America and south Asia,supplying obsolete and hard-to-find components to meet their specific needs.

With the principle of “Quality Parts,Customers Priority,Honest Operation,and Considerate Service”,our business mainly focus on the distribution of electronic components. Line cards we deal with include Microchip,ALPS,ROHM,Xilinx,Pulse,ON,Everlight and Freescale. Main products comprise IC,Modules,Potentiometer,IC Socket,Relay,Connector.Our parts cover such applications as commercial,industrial, and automotives areas.

We are looking forward to setting up business relationship with you and hope to provide you with the best service and solution. Let us make a better world for our industry!



Contact us

Tel: +86-755-8981 8866 Fax: +86-755-8427 6832

Email & Skype: info@chipsmall.com Web: www.chipsmall.com

Address: A1208, Overseas Decoration Building, #122 Zhenhua RD., Futian, Shenzhen, China



Type 4X Polyester Single/Two Door Freestanding Enclosure *PJFS*

Series

Continuous Hinge Door with Handle



Application

- Designed for use as instrument enclosures, electric, hydraulic or pneumatic control housings, electrical junction boxes or terminal wiring enclosures.
- Provides outstanding insulation and protection where equipment may be hosed down or be very wet.
- Ideal in applications with high temperatures or highly corrosive environments.

Standards

- UL/cUL 508 Type 1, 2, 3, 4, 4X, 12 and 13
- CSA Type 1, 2, 3, 4, 4X, 12 and 13
- Complies with
 - NEMA Type 1, 2, 3, 4, 4X, 12 and 13
 - IEC 60529, IP66

Construction

- Fiberglass polyester enclosure with matching door is easily punched, cut, or drilled.
- Enhanced UV inhibitors protect against outdoor weathering.
- Collar Studs are provided for optional inner panel.
- Mounting hardware included.
- Heavy duty continuous 304 SS Hinge.
- Flexible self-gripping gasket compresses over flange for tight seal.
- 3-point SS handle with pad lock provision.
- Molded in drip shield.
- Fiberglass mounting strut side walls on double door unit.
- Operating temperatures between 130°C and -40°C (266°F to -40°F).
- Impact index of 6.78J (5 ft/lb).
- For corrosion resistance information, please refer to table in the Technical Information section.

Finish

- Fiberglass polyester material has a gray finish.
- Optional inner panels are available in white powder coated finished steel.

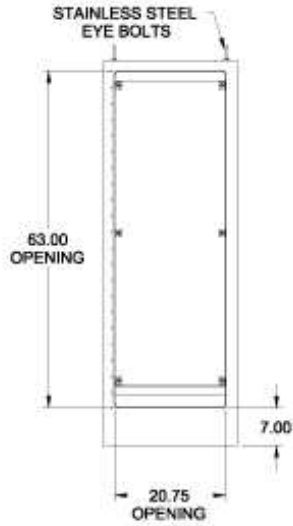
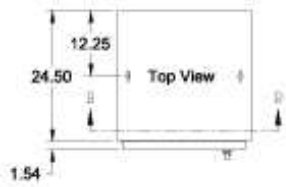

**Front View
(with Single Door Open)**

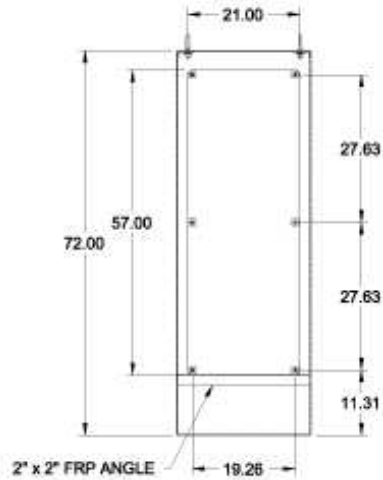

**SECTION B-B
Internal View**

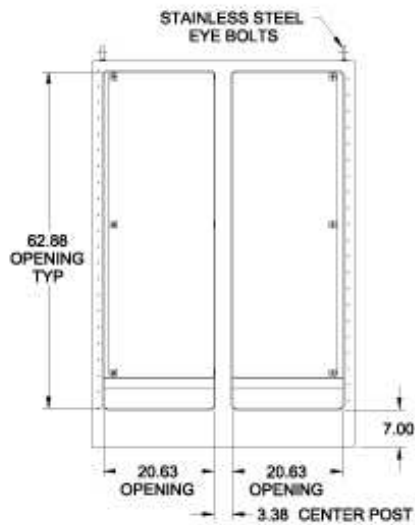
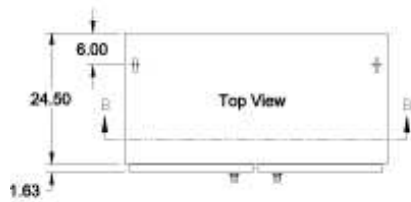

**Front View
(with Double Doors Open)**

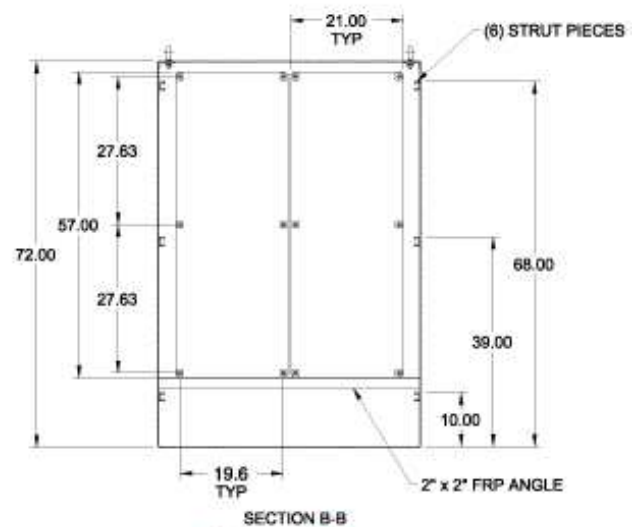
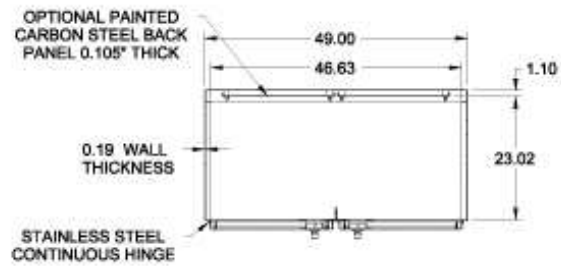

**SECTION B-B
Internal View**

Part No.	Enclosure				Panel		Notes	Finish	
	Height	Width	Depth	Ship Wt (lbs)	Panel Part No.	Height			Width
PJFS722525	72.00	25.00	24.50	215	18P5721	57.00	21.00	Qty 1 Required	White
PJFS724925DD	72.00	48.00	24.50	430	18P5721	57.00	21.00	Qty 2 Required	White

Data subject to change without notice

© 2017. Hammond Manufacturing Ltd. All rights reserved.