



Chipsmall Limited consists of a professional team with an average of over 10 year of expertise in the distribution of electronic components. Based in Hongkong, we have already established firm and mutual-benefit business relationships with customers from,Europe,America and south Asia,supplying obsolete and hard-to-find components to meet their specific needs.

With the principle of “Quality Parts,Customers Priority,Honest Operation,and Considerate Service”,our business mainly focus on the distribution of electronic components. Line cards we deal with include Microchip,ALPS,ROHM,Xilinx,Pulse,ON,Everlight and Freescale. Main products comprise IC,Modules,Potentiometer,IC Socket,Relay,Connector.Our parts cover such applications as commercial,industrial, and automotives areas.

We are looking forward to setting up business relationship with you and hope to provide you with the best service and solution. Let us make a better world for our industry!



Contact us

Tel: +86-755-8981 8866 Fax: +86-755-8427 6832

Email & Skype: info@chipsmall.com Web: www.chipsmall.com

Address: A1208, Overseas Decoration Building, #122 Zhenhua RD., Futian, Shenzhen, China



PJT Open Frame Power Supply

PJT-100WBA Series / PJT-□□V100WBA□

PJT

Highlights & Features

- Universal AC input voltage
- Standard industrial foot print of 3" x 5"
- Low leakage current < 0.1mA
- Convection cooled operating temperature range from -10°C to +70°C
- High MTBF > 700,000 hrs as per Telcordia SR-332
- Multiple connector source options

Safety Standards



CB Certified for worldwide use



Model Number: PJT-□□V100WBA□
Unit Weight: 0.21 kg (0.46 lb)
Dimensions (L x W x D): 127 x 76.2 x 31 mm [3" x 5"]

General Description

The PJT open frame power supply series offers choices of 12V, 15V, 18V and 24V nominal output voltages. The single output products are designed with small standard industrial foot prints at 3" x 5". The highly efficient convection cooling designs enable optimum thermal management for high power efficiency. The PJT series of products can operate from -10°C to +70°C across the entire input voltage range of 90 to 264Vac and are certified for safety standard according to IEC/EN/UL 60950-1 and for EMI standard according to EN 55022, Class B.

Model Information

PJT Open Frame Power Supply

Model Number	Input Voltage Range	Rated Output Voltage	Rated Output Current
PJT-12V100WBA□	90-264Vac	12Vdc	8.33A
PJT-15V100WBA□		15Vdc	6.67A
PJT-18V100WBA□		18Vdc	5.55A
PJT-24V100WBA□		24Vdc	4.17A

Model Numbering

PJ	T –	XXV	100W	B	A	□
Open Frame	Product Type T – ITE Application Series	Output Voltage 12V 15V 18V 24V	Output Power	Package Type B – Open Frame	Family Code A	Harness Connector A – JST connector B – Molex connector* C – JWT connector*

*Options

PJT Open Frame Power Supply

PJT-100WBA Series / PJT-□□V100WBA□

Specifications

	Model Number	PJT-12V100WBA□	PJT-15V100WBA□	PJT-18V100WBA□	PJT-24V100WBA□
--	--------------	----------------	----------------	----------------	----------------

Input Ratings / Characteristics

Nominal Input Voltage	100-240Vac				
Input Voltage Range	90-264Vac				
Nominal Input Frequency	50-60Hz				
Input Frequency Range	47-63Hz				
Input Current	< 1.50A typ. @ 115Vac				
Efficiency at 100% Load	115Vac	86.5% typ.	87.5% typ.	87.5% typ.	88.0% typ.
	230Vac				
Max Inrush Current (Cold Start)	30A typ. @ 115Vac, 60A typ. @ 230Vac				
Leakage Current	0.1mA @ 240Vac				

Output Ratings / Characteristics

Nominal Output Voltage	12Vdc	15Vdc	18Vdc	24Vdc
Factory Set Point Tolerance	No potentiometer (± 5%)			
Output Current	8.33A	6.67A	5.55A	4.17A
Output Power	100W			
Line Regulation	± 0.5% @ 115Vac & 230Vac			
Load Regulation	± 1.0% @ 115Vac & 230Vac			
PARD* (20MHz)	< 120mVpp	< 150mVpp	< 180mVpp	< 240mVpp
Start-up Time	115Vac	1000ms typ. (100% load)		
	230Vac			
Hold-up Time	115Vac	20ms typ. (100% load)		
	230Vac			
Dynamic Response (Overshoot & Undershoot O/P Voltage)	± 5% @ 0-50% load; 50-100% load (Slew Rate: 0.1A/μS)			
Start-up with Capacitive Loads	4,000uF Max	3,500uF Max	3,000uF Max	2,000uF Max

*PARD is measured with an AC coupling mode, 5cm wires, and in parallel with 0.1μF ceramic capacitor & 47μF electrolytic capacitor.

Mechanical

Dimensions	127 x 76.2 x 31 mm [3" x 5"]				
Unit Weight	0.21 kg (0.46 lb)				
Cooling System	Convection				
Power Supply Header	PJT-□□V100WBA <u>A</u>	Input: JST B2P3-VH (LF)(SN) Output: JST B8P-VH (LF)(SN)			
	PJT-□□V100WBA <u>B</u>	Input: Molex 26-62-4030 Output: Molex 26-60-4080			
	PJT-□□V100WBA <u>C</u>	Input: JWT A3963WV2-3P-D Output: JWT A3963WV2-8P			
Wire	AWG 22-18				

PJT Open Frame Power Supply

PJT-100WBA Series / PJT-□□V100WBA□

Environment

Surrounding Air Temperature	Operating	-10°C to +70°C
	Storage	-40°C to +85°C
Power De-rating	> 50°C de-rate power by 2.5% / °C	
Operating Humidity	10 to 95% RH (Non-Condensing)	
Operating Altitude	0 to 5,000 Meters (16,400 ft.)	
Shock Test (Non-Operating)	IEC 60068-2-27, Half Sine Wave: 50G for a duration of 11ms, 3 shocks for each 3 directions	
Vibration (Operating)	IEC 60068-2-6, Sine Wave: 10Hz to 150Hz @ 25m/S ² (2.5G); 10 min per cycle, 90 min per axis for all X, Y, Z direction	

Protections

Overvoltage	< 18.0V, Latch Mode	< 22.5V, Latch Mode	< 27.0V, Latch Mode	< 36.0V, Latch Mode
Overload / Overcurrent	< 150% of rated load current, Hiccup Mode, Non-Latching (Auto-Recovery)			
Over Temperature	Non-Latching (Auto-Recovery)			
Short Circuit	Hiccup Mode, Non-Latching (Auto-Recovery when the fault is removed)			
Protection Against Shock	Class I with PE* connection			

*PE: Primary Earth

Reliability Data

MTBF	> 700,000 hrs. as per Telcordia SR-332
Expected Cap Life Time	10 years (115Vac & 230Vac, 50% load @ 40°C)

Safety Standards / Directives

Electrical Safety	TUV Bauart UL/cUL recognized CB scheme	EN 60950-1 UL 60950-1 and CSA C22.2 No. 60950-1 (File No. E131881) IEC 60950-1
CE	In conformance with EMC Directive 2004/108/EC and Low Voltage Directive 2006/95/EC	
Material and Parts	RoHS Directive 2011/65/EU Compliant	
Galvanic Isolation	Input to Output	3.0KVac
	Input to Ground	1.5KVac
	Output to Ground	0.5KVac

PJT Open Frame Power Supply

PJT-100WBA Series / PJT-□□V100WBA□

EMC

EMC / Emissions	CISPR 22, EN 55022, FCC Title 47: Class B		
Immunity to	EN 55024		
Electrostatic Discharge	IEC 61000-4-2	Criteria A ¹⁾ Level 3 Air Discharge: 8kV Level 3 Contact Discharge: 6kV	
Radiated Field	IEC 61000-4-3	Level 2 Criteria A ¹⁾ 80MHz-1GHz, 3V/M with 1kHz tone / 80% modulation	
Electrical Fast Transient / Burst	IEC 61000-4-4	Level 3 Criteria A ¹⁾ 2kV	
Surge	IEC 61000-4-5	Level 3 Criteria A ¹⁾ Common Mode ²⁾ : 2kV Differential Mode ³⁾ : 1kV	
Conducted	IEC 61000-4-6	Level 2 Criteria A ¹⁾ 3V with 80% AM	
Power Frequency Magnetic Fields	IEC 61000-4-8	Criteria A ¹⁾ Magnetic field strength 3A/Meter	
Voltage Dips	IEC 61000-4-11	30% dip; 25ms Criterion A 60% dip; 100ms Criterion B 95% dip; 5000ms Criterion B	
Harmonic Current Emission	IEC/EN 61000-3-2, Class A		
Voltage Fluctuation and Flicker	IEC/EN 61000-3-3		

1) Criteria A: Normal performance within the specification limits

2) Asymmetrical: Common mode (Line to earth)

3) Symmetrical: Differential mode (Line to line)

Block Diagram

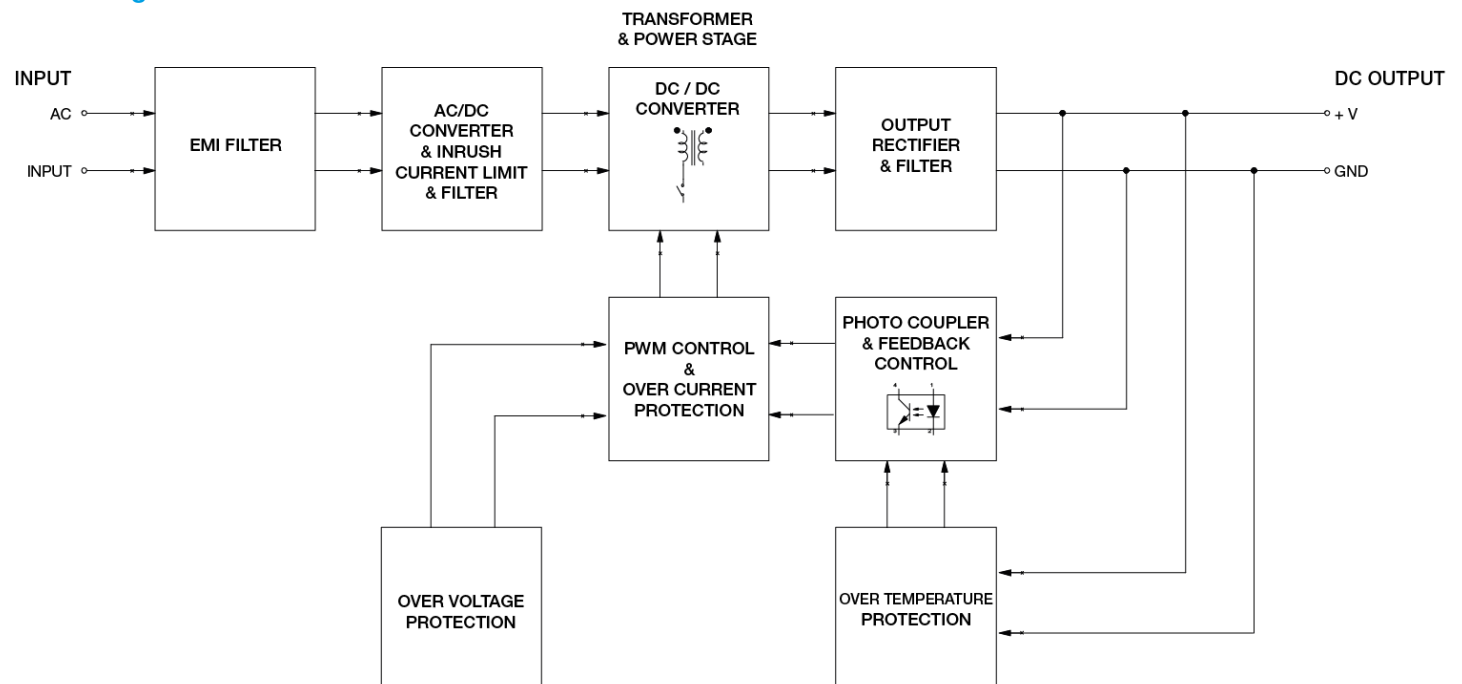

PJT Open Frame Power Supply

PJT-100WBA Series / PJT-□□V100WBA□

Dimensions

L x W x D: 127 x 76.2 x 31 mm [3" x 5"]

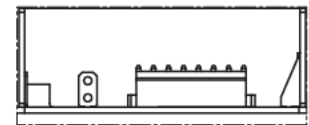
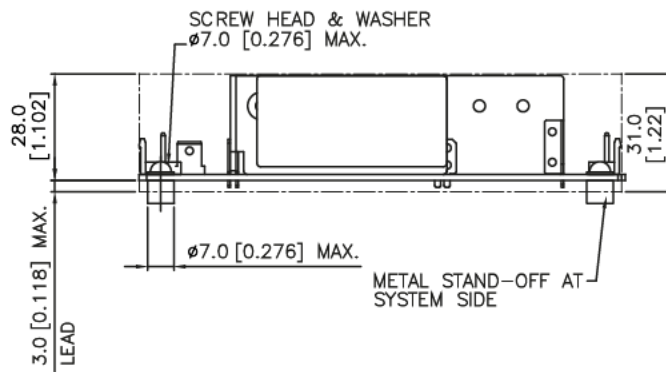
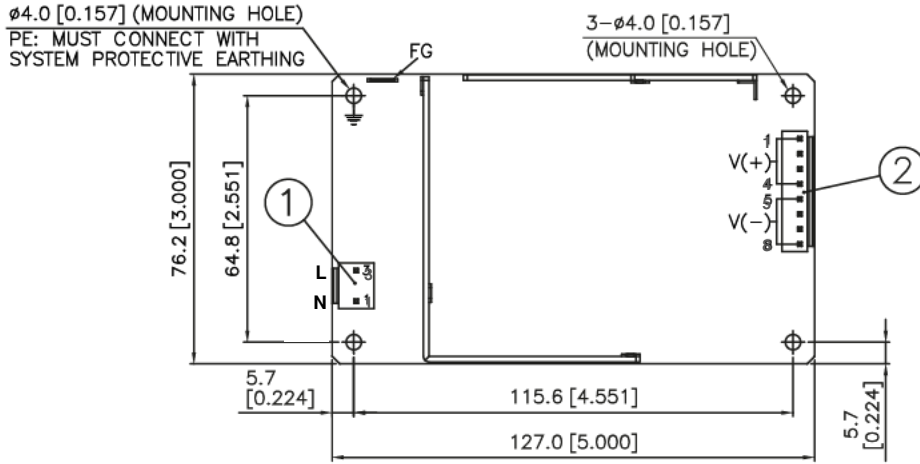

Item	Device Description
1	Input Connector (CN1) Pin 1: Neutral Pin 2: NC Pin 3: Line
2	Output Connector (CN101) Pin 1 to 4: V(+) Pin 5 to 8: V(-)

PJT Open Frame Power Supply

PJT-100WBA Series / PJT-□□V100WBA□

Engineering Data

Output Load De-rating VS Surrounding Air Temperature

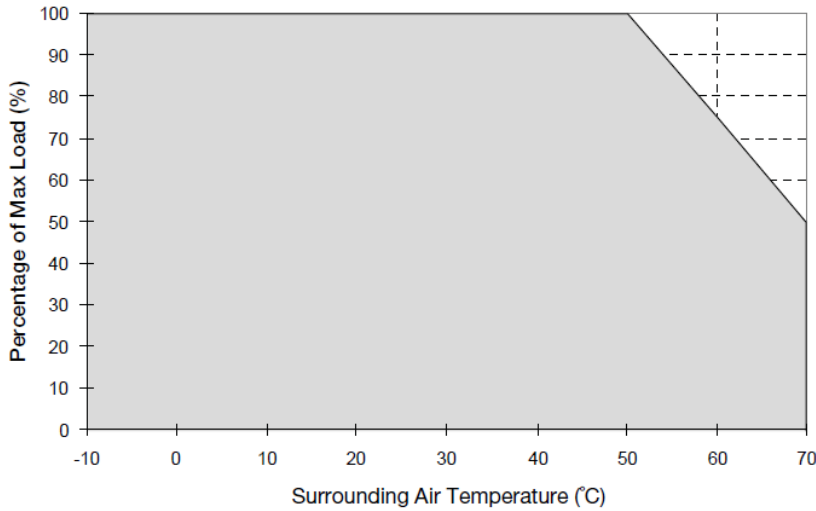
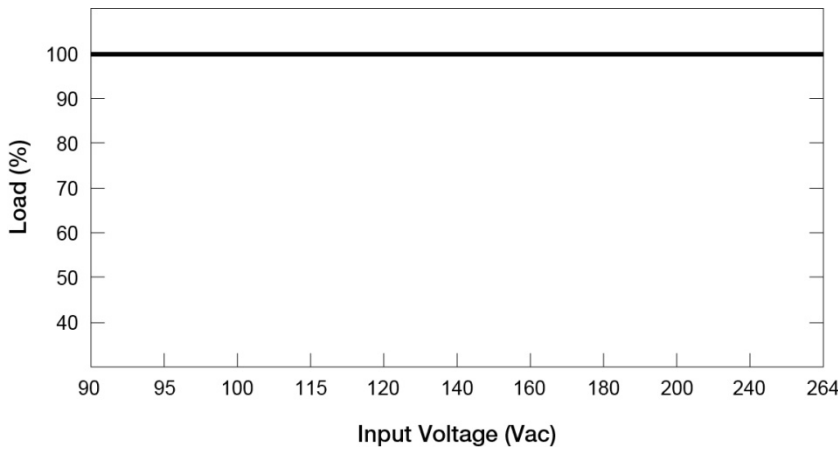

Fig. 1 De-rating for Horizontal Mounting Orientation
 > 50°C de-rate power by 2.5% / °C

Note

1. Power supply components may degrade, or be damaged, when the power supply is continuously used outside the shaded region, refer to the graph shown in Fig. 1.
2. If the output capacity is not reduced when the surrounding air temperature >50°C, the device will run into Over Temperature Protection. When activated, the output voltage will go into bouncing mode and will recover when the surrounding air temperature is lowered or the load is reduced as far as necessary to keep the device in working condition.
3. Depending on the surrounding air temperature and output load delivered by the power supply, the device can be very hot!
4. If the device has to be mounted in any other orientation, please contact info@deltapsu.com for more details.

Output Load De-rating VS Input Voltage



- No output power de-rating for the input voltage from 90Vac to 264Vac

PJT Open Frame Power Supply

PJT-100WBA Series / PJT-□□V100WBA□

Functions

Start-up Time

The time required for the output voltage to reach 90% of its final steady state set value, after the input voltage is applied.

Rise Time

The time required for the output voltage to change from 10% to 90% of its final steady state set value.

Hold-up Time

Time between the collapse of the AC input voltage, and the output falling to 95% of its steady state set value.

■ Graph illustrating the Start-up Time, Rise Time, and Hold-up Time

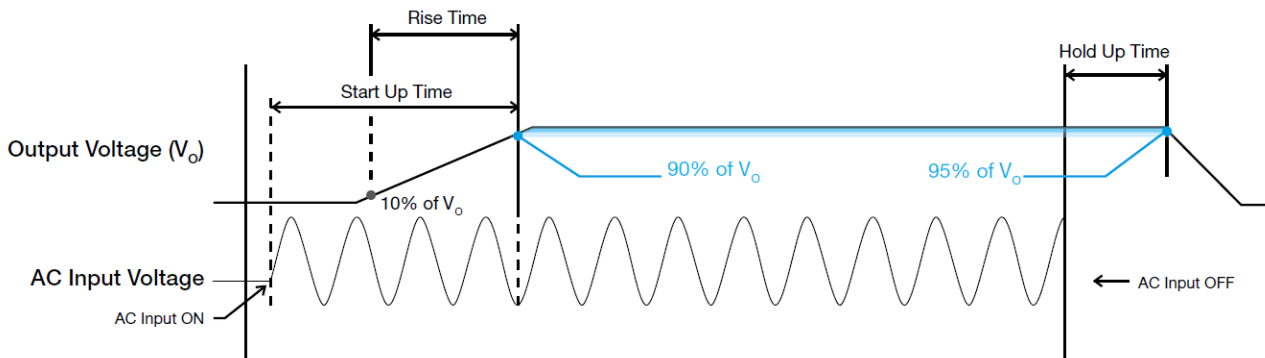

Inrush Current

Inrush current is the peak, instantaneous, input current measured and, occurs when the input voltage is first applied. For AC input voltages, the maximum peak value of inrush current will occur during the first half cycle of the applied AC voltage. This peak value decreases exponentially during subsequent cycles of AC voltage.

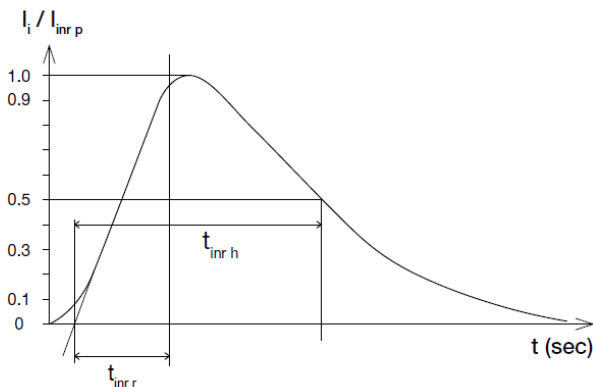

Dynamic Response

The power supply output voltage will remain within $\pm 5\%$ of its steady state value, when subjected to a dynamic load from 0 to 50% and 50 to 100% of its rated current.

■ 0 to 50% Load

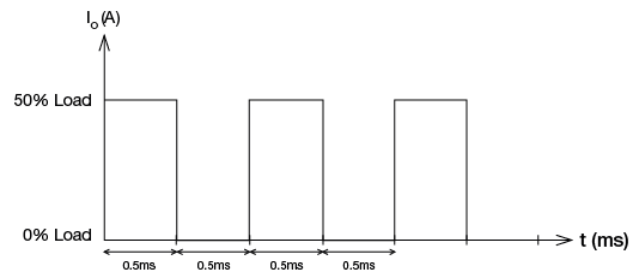

■ 50 to 100% Load

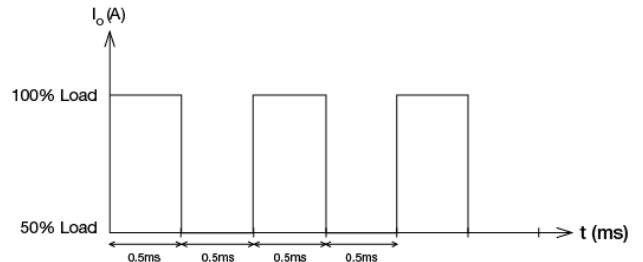

PJT Open Frame Power Supply

PJT-100WBA Series / PJT-□□V100WBA□

Overload & Overcurrent Protections (Auto-Recovery)

The power supply's Overload (OLP) and Overcurrent (OCP) Protections will be activated when output current exceeds 150% of I_O (Max load). In such occurrence, the V_O will start to droop and once the power supply has reached its maximum power limit, the protection is activated and the power supply will go into "Hiccup mode" (Auto-Recovery). The power supply will recover once the fault condition of the OLP and OCP is removed and I_O is back within the specifications.

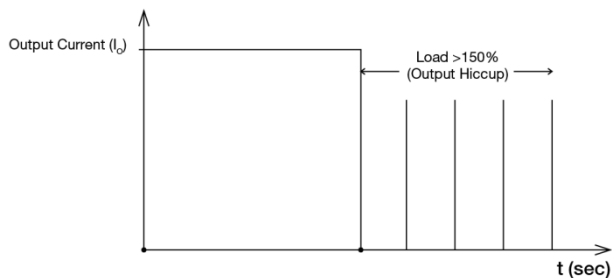

It is not recommended to prolong the duration of I_O when it is <150% but >100%, since it may cause damage to the PSU.

Short Circuit Protection (Auto-Recovery)

The power supply's output OLP/OCP function also provides protection against short circuits. When a short circuit is applied, the output current will operate in "Hiccup mode", as shown in the illustration in the OLP/OCP section on this page. The power supply will return to normal operation after the short circuit is removed.

Others

Delta RoHS Compliant



Restriction of the usage of hazardous substances

The European directive 2011/65/EU limits the maximum impurity level of homogeneous materials such as lead, mercury, cadmium, chrome, polybrominated flame retardants PBB and PBDE for the use in electrical and electronic equipment. RoHS is the abbreviation for "Restriction of the use of certain hazardous substances in electrical and electronic equipment".

This product conforms to this standard.

PFC – Norm EN 61000-3-2



Line Current Harmonic content

Typically, the input current waveform is not sinusoidal due to the periodical peak charging of the input capacitor. In industrial environment, complying with EN 61000-3-2 is only necessary under special conditions. Complying to this standard can have some technical drawbacks, such as lower efficiency as well as some commercial aspects such as higher purchasing costs. Frequently, the user does not profit from fulfilling this standard, therefore, it is important to know whether it is mandatory to meet this standard for a specific application.

Overvoltage Protection (Latch Mode)

The power supply's overvoltage circuit will be activated when its internal feedback circuit fails. The output voltage shall not exceed its specifications defined on Page 3 under "Protections". Power supply will latch off, and require removal/re-application of input AC voltage in order to restart.

The power supply should be latch.

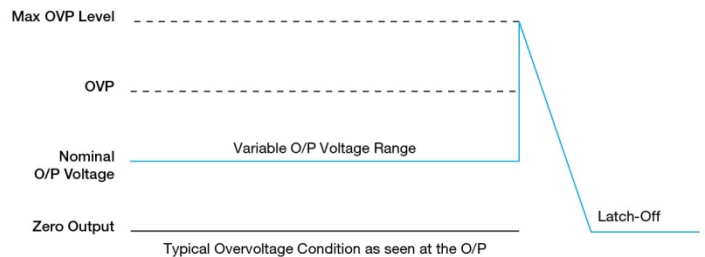

Over Temperature Protection (Auto-Recovery)

As described in load de-rating section, the power supply also has Over Temperature Protection (OTP). In the event of a higher operating temperature at 100% load, the power supply will run into OTP when the operating temperature is beyond what is recommended in the de-rating graph. When activated, the output voltage will go into bouncing mode until the temperature drops to its normal operating temperature as recommended in the de-rating graph.