



Chipsmall Limited consists of a professional team with an average of over 10 year of expertise in the distribution of electronic components. Based in Hongkong, we have already established firm and mutual-benefit business relationships with customers from,Europe,America and south Asia,supplying obsolete and hard-to-find components to meet their specific needs.

With the principle of “Quality Parts,Customers Priority,Honest Operation,and Considerate Service”,our business mainly focus on the distribution of electronic components. Line cards we deal with include Microchip,ALPS,ROHM,Xilinx,Pulse,ON,Everlight and Freescale. Main products comprise IC,Modules,Potentiometer,IC Socket,Relay,Connector.Our parts cover such applications as commercial,industrial, and automotives areas.

We are looking forward to setting up business relationship with you and hope to provide you with the best service and solution. Let us make a better world for our industry!



Contact us

Tel: +86-755-8981 8866 Fax: +86-755-8427 6832

Email & Skype: info@chipsmall.com Web: www.chipsmall.com

Address: A1208, Overseas Decoration Building, #122 Zhenhua RD., Futian, Shenzhen, China





TELEDYNE LECROY
Everywhereyoulook™



Operator's Manual

ZS1000, ZS1500, ZS2500
High-Impedance,
Active Probe

ZS1000, ZS1500, ZS2500
High-Impedance Active Probes
Operator's Manual



© 2014 Teledyne LeCroy, Inc. All rights reserved.

Unauthorized duplication of Teledyne LeCroy documentation materials other than for internal sales and distribution purposes is strictly prohibited. However, clients are encouraged to distribute and duplicate Teledyne LeCroy documentation for their own internal educational purposes.

WaveSurfer, WaveRunner, WavePro, WaveMaster and Teledyne LeCroy are registered trademarks of Teledyne LeCroy, Inc. Windows is a registered trademark of Microsoft Corporation. Other product or brand names are trademarks or requested trademarks of their respective holders. Information in this publication supersedes all earlier versions. Specifications are subject to change without notice.

Warranty

Teledyne Lecroy warrants this oscilloscope accessory for normal use and operation within specification for a period of one year from the date of shipment. Spare parts, replacement parts and repairs are warranted for 90 days.

In exercising its warranty, Teledyne LeCroy, at its option, will either repair or replace any assembly returned within its warranty period to the Customer Service Department or an authorized service center. However, this will be done only if the product is determined by Teledyne LeCroy's examination to be defective due to workmanship or materials, and the defect is not caused by misuse, neglect, accident, abnormal conditions of operation, or damage resulting from attempted repair or modifications by a non-authorized service facility.

The customer will be responsible for the transportation and insurance charges for the return of products to the service facility. Teledyne LeCroy will return all products under warranty with transportation charges prepaid.

This warranty replaces all other warranties, expressed or implied, including but not limited to any implied warranty of merchantability, fitness or adequacy for any particular purposes or use. Teledyne LeCroy shall not be liable for any special, incidental, or consequential damages, whether in contract or otherwise.

924282-00

May, 2014

TABLE OF CONTENTS

Safety Instructions	1
Symbols.....	1
Precautions	1
Operating Environment	2
Introduction.....	2
Key Benefits	2
Standard Accessories	3
Features and Accessories	4
Tips.....	5
Grounds.....	7
Leads.....	8
Grabbers	8
Probe Holder	9
Probe Operation.....	9
Handling the Probe	9
Connecting the Probe to an Oscilloscope.....	9
Operation with a Teledyne LeCroy Oscilloscope	10
Connecting the Probe to the Test Circuit	10
High Frequency Measurements	11
Probe Impedance and Equivalent Circuit	14
ZS1x00 Impedance	14
ZS1x00 Equivalent Circuit.....	14
ZS2500 Impedance.....	15
ZS2500 Equivalent Circuit.....	15

ZS Series High-Impedance, Active Probes

Care and Maintenance	16
Cleaning	16
Calibration Interval	16
Service Strategy	16
Returning a Probe for Calibration or Service	16
Replacement Parts	18
Performance Verification	18
Required Test Equipment.....	18
Preliminary Procedure	19
Functional Check.....	20
Verification Procedure	21
Performance Verification Test Record	24
Reference Material	26
Specifications	26
Certifications	26
Contact Teledyne LeCroy.....	28

Safety Instructions

This section contains instructions that must be observed to keep this oscilloscope accessory operating in a correct and safe condition. You are required to follow generally accepted safety procedures in addition to the precautions specified in this section. **The overall safety of any system incorporating this accessory is the responsibility of the assembler of the system.**

Symbols

These symbols may appear on the probe body or in this manual to alert you to important safety considerations.



CAUTION. Potential for damage to probe or instrument it is connected to. Attend to the accompanying information to protect against personal injury or damage. Do not proceed until conditions are fully understood and met.



ELECTROSTATIC DISCHARGE (ESD) HAZARD. The probe is susceptible to damage if anti-static measures are not taken.



DOUBLE INSULATION

Precautions

Connect and disconnect properly. Connect probe to the measurement instrument before connecting the test leads to a circuit/signal being tested.

Use only within operational environment listed. Do not use in wet or explosive atmospheres.

Use indoors only.

Keep product surfaces clean and dry.

Be careful with sharp tips. The tips may cause bodily injury if not handled properly.

Do not operate with suspected failures. Do not use the probe if any part is damaged. Cease operation immediately and sequester the probe from inadvertent use.

Operating Environment

The accessory is intended for indoor use and should be operated in a clean, dry environment. Before using this product, ensure that its operating environment is maintained within these parameters:

Temperature: 5 to 40° C.

Humidity: Maximum relative humidity 80 % for temperatures up to 31 °C decreasing linearly to 50 % relative humidity at 40° C.

Altitude: Up to 10,000 ft (3,048 m).

Introduction

The ZS1000, ZS1500, and ZS2500 are small, high impedance active probe designed to meet today's increasing demand for measurements on a variety of test points. With low input capacitance and high input resistance, circuit loading is minimized.

The ZS2500 can be used with Teledyne LeCroy's WaveSurfer, WaveRunner, WavePro and WaveMaster series platforms with firmware version 6.5.0.5 or later.

With the ProBus interface, the ZS1000, ZS1500, and ZS2500 become an integral part of the oscilloscope. The probe can be controlled from the oscilloscope's front panel. The oscilloscope provides power to the probe, so there is no need for a separate power supply or batteries.

Key Benefits

- High frequency performance
- Low input capacitance
- Wide dynamic range
- ProBus interface

Standard Accessories

The ZS1000, ZS1500, and ZS2500 probes are shipped with the following standard accessories:

Standard Accessory	Quantity	Replacement Part Number
Straight Pin Lead – Short	1	PK-ZS-003
Straight Pin Lead – Long	1	PK-ZS-004
Right Angle Lead – Short	1	PACC-LD003
Right Angle Lead – Long	1	PACC-LD004
Y Lead Adapter	1	PK-ZS-005
Micro-Grabber Pair	1	PK-ZS-007R and PK-ZS-007B
Ground Blade – Wide	1	PK-ZS-011
Probe Tip – Standard	3	PK-ZS-001
Right Angle Socket	1	PK-ZS-006
Offset Ground – Z Lead	1	PK-ZS-002
Ground Blade – Narrow	1	PK-ZS-008
Copper Tape	2	PK-ZS-009
Pogo Tip	1	PK-ZS-013
2.54mm Square Pin Adapter	1	PK-ZS-012
Channel ID Clips (Set of 4 colors)	4	PK-ZS-010
Freehand Probe Holder	1	PACC-MS005
Bent Tip	1	PACC-PT005
IC Tip	1	PACC-PT003
Pogo Ground Lead	1	PACC-CD008
Instruction Manual	1	ZSSERIES-OM-E
Certificate of Calibration	1	ZS-CC

For part number information for standard and optional accessories refer to, Care and Maintenance, Replaceable Parts List.

Features and Accessories

The ZS1000, ZS1500, and ZS2500s probes are provided with numerous features and accessories to make probing and connecting to different test points easier than ever.

- The small, low mass probe head is designed for ease of use and high performance.
- The probe tip socket fits easily onto 0.025 inch square pins for direct access to test points. Several different adapters are available which connect directly in the probe socket.
- The ground socket will accept several different ground leads to provide a short ground path for high frequency performance.

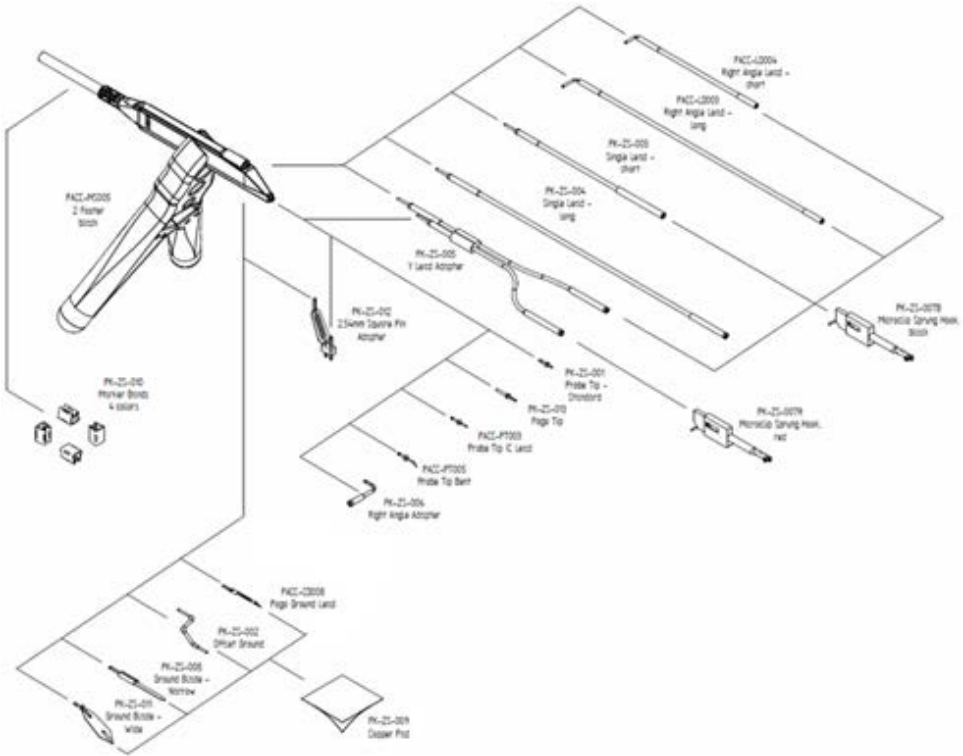

ZS1000, ZS1500, ZS2500 Probe Exploded-View Diagram

Tips

Straight Tip



The straight tip is rugged and designed for general probing. Fits in either probe socket. (PK-ZS-001)

IC Lead Tip



The IC Lead Tip is covered in insulation on all sides (except for a small edge), this tip was designed to prevent shorting neighboring IC leads. The gold part of the tip is not insulated and should touch the IC lead to be tested. It is one-size-fits-all and will work with any IC lead pitch. Fits in either probe socket. (PACC-PT003)

Bent Tip

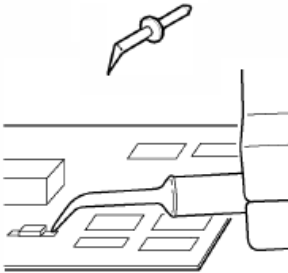

The Bent Tip is made out of titanium, this tip is ideal for situations that require the user to hold the probe parallel to the circuit board under test. Also gives you more control when holding the probe like a pencil. Fits in either probe socket. (PACC-PT005)

Pogo Tip



The pogo tip provides z axis compliance. The tip can fit into a socket or via and onto an IC leg.

Tips, continued

Discrete SMD Tip

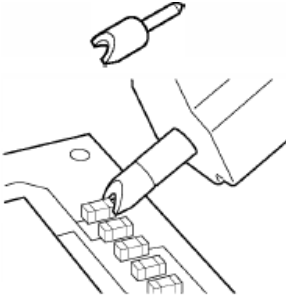

The crescent shape of this tip is designed to fit tightly on capacitors, resistors, transistors and other surface mount components with discrete leads. Fits in either probe socket.

2.54 mm Square Pin Adapter



2.54 mm Square Pin Adapter. The 2.54 mm square pin adapter fits into both the input and ground lead of the ZS probe for easy connection to standard 2.54 mm square pin spacing on a circuit board.

Grounds

Offset Ground



The offset pin is designed to be attached to either socket of the probe head. The offset pin is the highest quality grounding solution and is recommended in high frequency applications.

The offset ground is designed to connect to the ground socket and wrap around the probe head. This gives the ability to a probe signal and ground that are extremely close together. The short length provides high-quality grounding for high-frequency applications.

Ground Blade (narrow) and Copper Pad



The Ground Blade and Copper Pad are intended to work together for the best grounding solution for probing an IC. The Ground Blade is designed to provide a short, low inductance ground path. The Copper Pad is adhesive backed to stick to the top of an IC, and can then be soldered to the IC ground.



Ground Blade (wide)

The wide ground blade is ideal for use when the best quality ground is needed. The wide blade offers the minimal inductance compared to the narrow ground blade.



ZS Series High-Impedance, Active Probes

Leads

While longer leads provide greater flexibility when connecting the probe to a circuit, the added inductance may degrade the fidelity of high frequency signals. See Section 4 for additional information.

Short and Long Straight Pin Lead

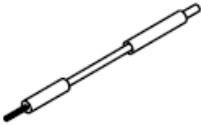

These leads have a socket on one end and a square pin on the other to connect to the input or ground socket of the probe body, and may be used for general purpose probing.

Short and Long Right Angle Pin Lead



These leads have a socket on one end with a right angle and a square pin on the other to connect to the input or ground socket of the probe body, and may be used for general purpose probing.

Y Lead Adapter

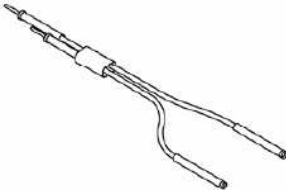

This lead is used for both ground and input lead simultaneously. It has two sockets on one end and two square pins on the other and may be used for general purpose probing.

Grabbers

Micro- and Mini-Grabbers



The micro-grabbers are ideal for connecting to small IC legs or pins very tightly spaced.

Probe Holder

Freehand Probe Holder The *FreeHand* lets you focus on the oscilloscope screen instead of on maintaining contact to multiple test points. It allows the user to concentrate on what is really important – the waveform.

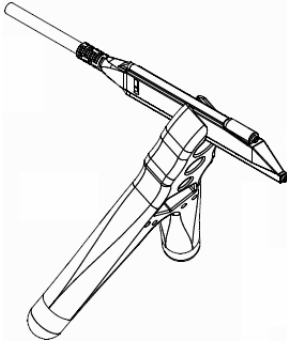

It is designed to keep most of the weight on the probe tip and will prevent lost contact when a bump to the table shakes the circuit under test.

Probe Operation

Handling the Probe

The ZS series probe is a precision test instrument. Exercise care when handling and storing the probe. Always handle the probe by the probe body or compensation box. Avoid putting excessive strain or exposing the probe cable to sharp bends.



ESD Sensitive: The tips of the probes are sensitive to Electrostatic Discharge (ESD). Avoid causing damage to the probe by always following anti-static procedures (wear wrist strap, etc.) when using or handling the probe.

Connecting the Probe to an Oscilloscope

The ZS1000, ZS1500, and ZS2500 probes have been designed for use with Teledyne LeCroy's WaveSurfer, WaveRunner, WavePro, and WaveMaster platforms equipped with the ProBus interface. When you attach the probe output connector to the oscilloscope's input connector, the oscilloscope recognizes the probe, provides proper termination and activates the probe control functions in the user interface.

ZS Series High-Impedance, Active Probes

Operation with a Teledyne LeCroy Oscilloscope

When the ZS1000, ZS1500, or ZS2500 probe is connected to any compatible Teledyne LeCroy oscilloscope, the displayed scale factor and measurement values are automatically adjusted.

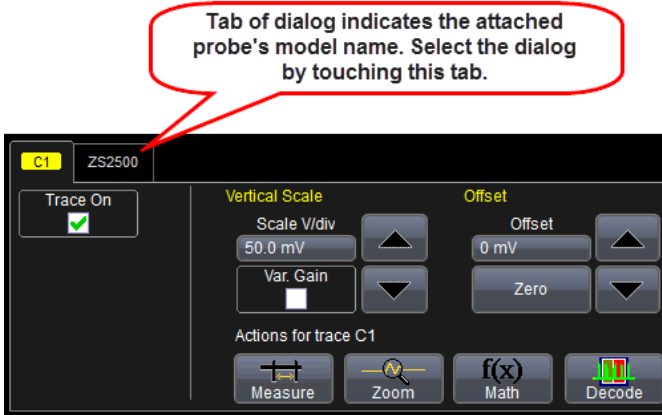

The probe can be controlled through the oscilloscope graphical user interface. When connected, a Probe dialog appears behind the corresponding channel dialog. Refer to your oscilloscope's manual for specific operation instructions.

Turning the **Volts/Div** knob controls the oscilloscope's scale factor to give full available dynamic range up to 2 V/div (16 V peak to peak). Turning the channel Offset knob controls the probe input offset circuit over its range of ± 12 V.

Connecting the Probe to the Test Circuit

To maintain the high performance capability of the probe in measurement applications, care must be exercised in connecting the probe to the test circuit. Increasing the parasitic capacitance or inductance in the input paths may introduce a "ring" or slow the rise time of fast signals. Input leads which form a large loop area will pick up any radiated electromagnetic field which passes through the loop and may induce noise into the probe input.

Using one of the available accessories makes the ZS2500 probe with its small profile and low mass head ideally suited for applications in dense circuitry.

High Frequency Measurements

Probe Input Loading

When you touch a probe to the circuit under test, the probe will affect your measurement because of the probe's input impedance introduced into the circuit. All probes present resistive, capacitive and inductive loading.

Inductive Loading (Lead Length)

A significant element in this circuit is the inductance shown in the input ground leads of the oscilloscope probe.

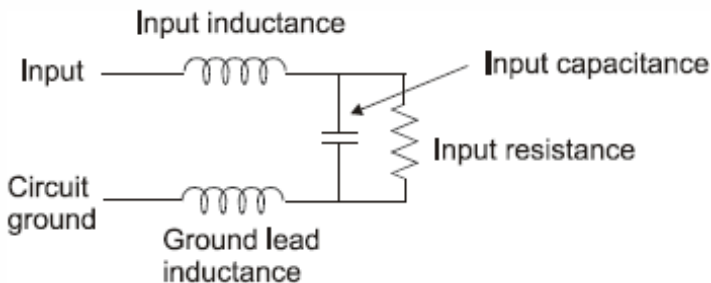

Example probe input equivalent circuit. Actual diagrams p.14.

The ground lead is the primary return path for the current resulting from the input voltage acting on the probe's input impedance. The ground lead and input lead inductances act with the probe's input capacitance to form series L-C network. The impedance of a series LC network drops dramatically at its resonant frequency. This is the cause of the "ring" we often see after the leading edge of pulses in measured waveforms.

This effect is referred to as ground lead corruption. Because it is impossible to eliminate either the L or C from this circuit, the method to improve waveform fidelity is to raise the resonant frequency beyond the bandwidth of interest in the measurement.

The resonant frequency of a simple LC circuit can be represented by:

$$F_{Resonance} = \frac{1}{2\pi\sqrt{LC}}$$

ZS Series High-Impedance, Active Probes

The resonant frequency of a series LC circuit can be raised by decreasing the inductance, capacitance or both. Since the input capacitance is already very low and cannot be reduced, you can only try to reduce the inductance. This can be accomplished by using the shortest possible input lead as well as the shortest possible ground lead.

For example, to obtain the shortest possible ground lead when measuring IC related signals, attach a small piece of copper clad material to the top of the IC package and connect this to the package grounding wires.

Using the shortest ground lead and input lead available makes probing signals on the package easier and makes for the shortest lead length for the best signal fidelity. To illustrate how dramatic this effect is, we will work a simple example. Assuming an input capacitance of 0.9 pF and a total lead length (input and ground) of 2 inches (inductance of ≈ 25 nH/inch) such a setup may cause ringing with a resonant frequency (f_0) of:

$$f_0 = \frac{1}{2\pi\sqrt{50 \times 10^{-9} \times 0.9 \times 10^{-12}}} = 750 \text{ MHz}$$

This frequency is well within the passband of the probe and therefore shows up as part of the measured signal at faster time/div settings. To determine how fast a waveform to be measured can be without causing ringing on a probe like this, divide the BW (ringing frequency) of the probe into 0.35:

$$t_{rise} = \frac{0.35}{BW} = \frac{0.35}{750 \text{ MHz}} = 0.47 \text{ ns}$$

Any input signal with a rise time faster than 0.47 ns can cause ringing.

Capacitive Loading

Capacitive loading is usually the most troublesome of the three loading effects. It can affect the rise time, bandwidth and delay time measurements. At higher frequencies the capacitive loading can affect the amplitude as well as the waveshape of the measured signal by introducing an exponential response to the waveform.

For a simple RC network the time constant of this exponential response is:

$$t_{rise} = 2.2 \times C_{total} \times R_{total}$$

Where C_{total} is the combined probe and circuit capacitance and R_{total} is combined circuit and probe resistance.

For a setup where $C_t = 0.9$ pF and a source resistance is 250Ω , the measured rise time will be 0.495 ns, which will correspond to a bandwidth of 909 MHz, assuming no inductive loads.

$$t_{rise} = 2.2 \times 0.9 \times 10^{-12} \times 250 \Omega = 0.495 \text{ ns}$$

Parallel combination of 250Ω and $1 \text{ M}\Omega$ is still 250Ω

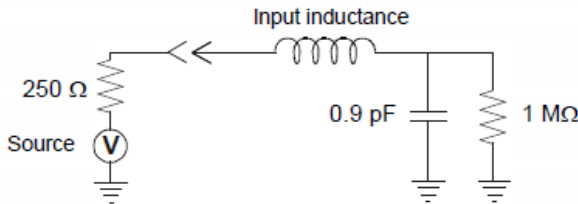

Example Probe input equivalent circuit. Actual diagrams p.14.

To illustrate the effect of capacitive loading at higher frequencies:

At a frequency of 750 MHz the reactance of the 0.9 pF capacitance is 236Ω , and at 1.0 GHz the reactance has been lowered to 177Ω .

If, at a given frequency, the source impedance is large with respect to the input impedance, a measurable reduction in the output signal amplitude may occur.

$$V_{out} = \frac{Z_{probe}}{Z_{probe} + Z_{source}} \times V_{in}$$

where Z_{probe} is the probe's input impedance and Z_{source} is the source impedance.

For example: At 750 MHz, where the probe input impedance has reduced to 236Ω , and a source resistance of 250Ω the probe output amplitude is reduced to:

$$V_{out} = \frac{236}{236 + 250} = 0.49 \times V_{in}$$

Probe Impedance and Equivalent Circuit

ZS1x00 Impedance

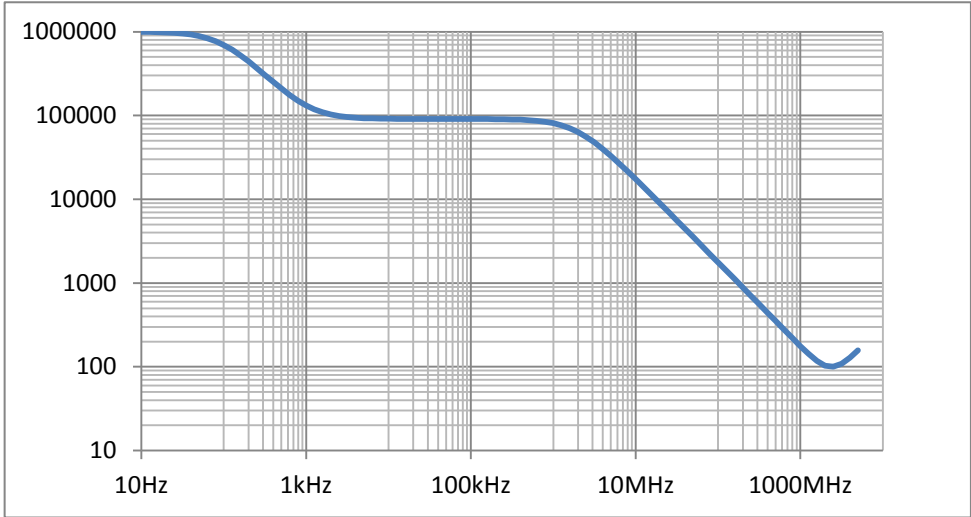

ZS1x00 Equivalent Circuit

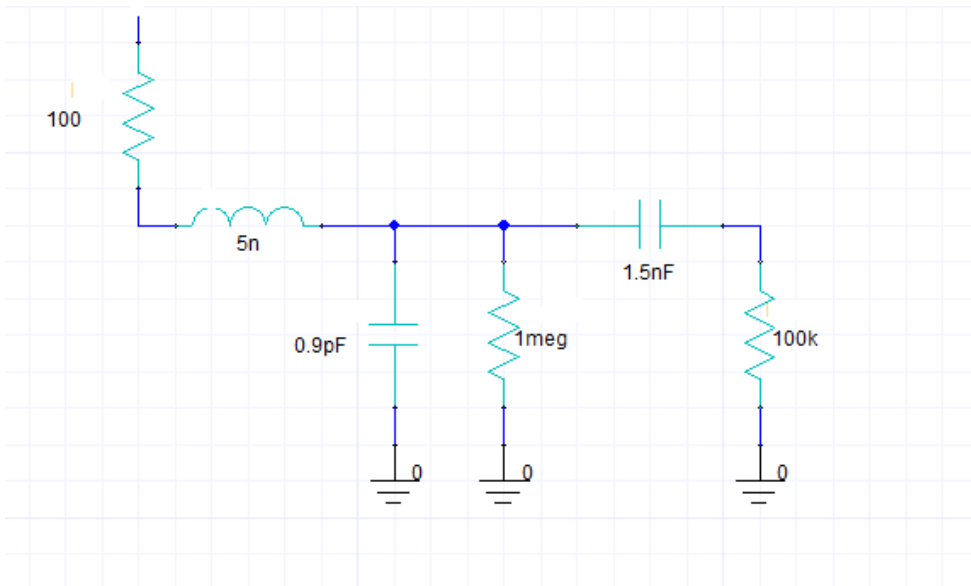

ZS2500 Impedance

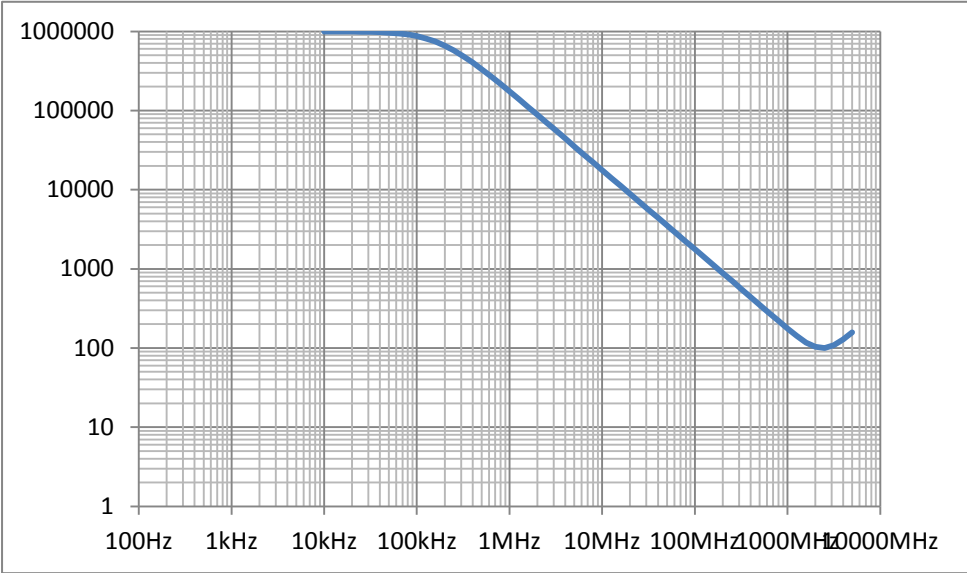

ZS2500 Equivalent Circuit

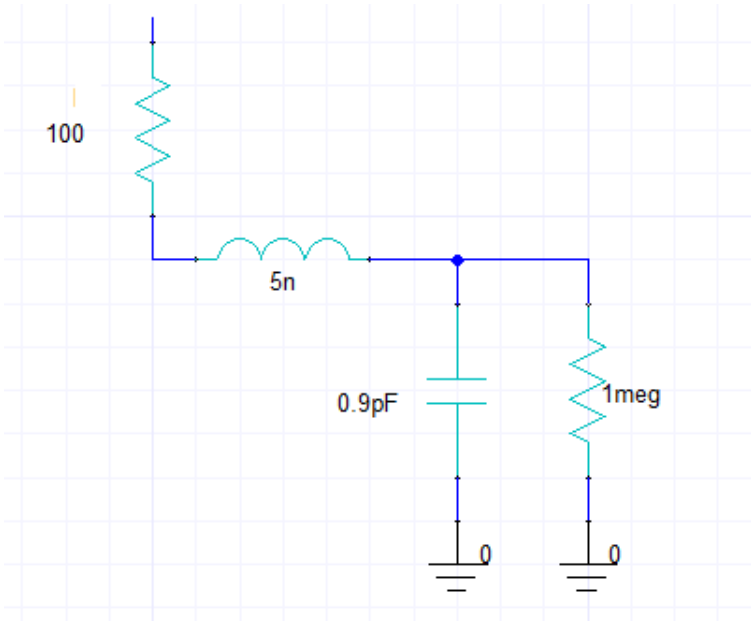

Care and Maintenance

Cleaning

The exterior of the probe and cable should be cleaned, using a soft cloth moistened with water. The use of abrasive agents, strong detergents, or other solvents may damage the probe. Always ensure that the input leads are free of debris.



CAUTION. The probe case is not sealed and should never be immersed in any fluid.

Calibration Interval

The recommended calibration interval is one year from the time the probe is put into service.

Service Strategy

The ZS1000, ZS1500, and ZS2500 probes utilize fine pitch surface mount devices. It is therefore impractical to attempt to repair in the field. Defective probes must be returned to a Teledyne LeCroy service facility for diagnosis and exchange. Defective probes under warranty are repaired or replaced. A probe that is not under warranty can be exchanged for a factory refurbished probe for a modest fee. You must return the defective probe in order to receive credit for the probe core.

Returning a Probe for Calibration or Service

Return a probe for calibration or service by contacting your local Teledyne LeCroy sales representative. They will tell you where to return the product. All returned products should be identified by both **model** and **serial number**. Provide your **name** and **contact number**, and a **description of the defect or failure** (if possible).

Products returned to the factory require a **Return Material Authorization (RMA)** acquired by contacting your nearest Teledyne LeCroy sales office, representative or the North America Customer Care Center.

NOTE: It is important that the RMA be clearly shown on the outside of the shipping package for prompt redirection to the appropriate department.

Return shipment should be prepaid. **Teledyne LeCroy cannot accept COD or Collect Return shipments.** We recommend air-freighting.

Follow these steps for a smooth product return.

1. Contact your local Teledyne Lecroy sales or service representative to obtain a Return Material Authorization.
2. Remove all accessories from the probe. Do not include the manual.
3. Pack the probe in its case, surrounded by the original packing material (or equivalent) and box.
4. Label the case with a tag containing
 - The RMA
 - Name and address of the owner
 - Probe model and serial number
 - Description of failure
5. Package the probe case in a cardboard shipping box with adequate padding to avoid damage in transit.
6. Mark the outside of the box with the shipping address given to you by the Teledyne Lecroy representative; be sure to add the following:
 - ATTN: <RMA assigned by the Teledyne Lecroy representative>
 - FRAGILE
7. Insure the item for the replacement cost of the probe.
8. **If returning a probe to a different country, also:**
 - Mark shipments returned for service as a "Return of US manufactured goods for warranty repair/recalibration."
 - If there is a cost involved in the service, put the service cost in the value column and the replacement value of the probe in the body of the invoice marked "For insurance purposes only."
 - Be very specific as to the reason for shipment. Duties may have to be paid on the value of the service.

Replacement Parts

The probe connection accessories and other common parts can be ordered through the North America Customer Care Centers. Refer to **Standard Accessories** table after the Introduction of this manual.

Performance Verification

This procedure can be used to verify the warranted characteristics of the ZS1000, ZS1500, and ZS2500 High Impedance Active Probe.

The recommended calibration interval for the model ZS1000, ZS1500, and ZS2500 is one year. The complete performance verification procedure should be performed as the first step of annual calibration. Test results can be recorded on a photocopy of the Test Record provided in Appendix A at the end of the manual.

Performance verification can be completed without removing the probe covers or exposing the user to hazardous voltages. Adjustment should only be attempted if a parameter measured in the Performance Verification Procedure is outside the specification limits.

NOTE: Adjustment should only be performed by qualified personnel

This procedure tests the following specifications:

- Output Zero Voltage
- LF Attenuation Accuracy

Required Test Equipment

The **Standard Accessories** table after the Introduction of this manual lists the test equipment and accessories (or their equivalents) that are required for performance verification of the ZS1000, ZS1500, and ZS2500 probes.

This procedure has been developed to minimize the number of calibrated test instruments required.

Only the parameters listed in boldface in the Minimum requirements column must be calibrated to the accuracy indicated.

Because the input and output connector types may vary on different brands and models of test instruments, additional adapters or cables may be required.

List of Required Equipment

Description	Minimum Requirement	Test Equipment Examples
Digital Oscilloscope	ProBus Interface; Windows-based	Teledyne LeCroy WaveRunner WaveSurfer Xs
Digital Multimeter (DMM) with test probe leads	4.5 digit DC: 0.1% Accuracy AC: 0.1% Accuracy	Agilent Technologies 34401A Fluke 8842A-09
Function Generator	Sine Wave output amplitude adjustable to 14.14 Vp-p (5 Vrms) into 1 M Ω at 70 Hz	Agilent Technologies 33120A Stanford Research DS340
Power Supply	0-12 V, settable to 10 mV	HP E3611A
BNC Coaxial Cable (2 ea.)	Male to Male, 50 Ω , 36" Cable	Pomona 2249-C-36 Pomona 5697-36
BNC Tee Connector	Male to Dual Female	Pomona 3285
Calibration Fixture	ProBus Extender Cable	Teledyne LeCroy PROBUS-CF01
Terminator, Precision, BNC	50 Ω \pm 0.05%	Teledyne LeCroy TERM-CF01
Banana Plug Adapter (2 ea.)	Female BNC to Dual Banana Plug	Pomona 1269
BNC to Mini-grabber	BNC Mail to Mini-grabber Cable, 36"	Pomona 5187-C-36

Preliminary Procedure

1. Connect the ZS1000, ZS1500, or ZS2500 probe to the female end of the ProBus Extension Cable. Connect the male end of the ProBus Extension Cable to channel 1 of the oscilloscope.
2. Turn the oscilloscope on and allow at least 30 minutes warm-up time for the ZS1000, ZS1500, or ZS2500 and test equipment before performing the Verification Procedure.