



Chipsmall Limited consists of a professional team with an average of over 10 year of expertise in the distribution of electronic components. Based in Hongkong, we have already established firm and mutual-benefit business relationships with customers from,Europe,America and south Asia,supplying obsolete and hard-to-find components to meet their specific needs.

With the principle of "Quality Parts,Customers Priority,Honest Operation,and Considerate Service",our business mainly focus on the distribution of electronic components. Line cards we deal with include Microchip,ALPS,ROHM,Xilinx,Pulse,ON,Everlight and Freescale. Main products comprise IC,Modules,Potentiometer,IC Socket,Relay,Connector.Our parts cover such applications as commercial,industrial, and automotives areas.

We are looking forward to setting up business relationship with you and hope to provide you with the best service and solution. Let us make a better world for our industry!



Contact us

Tel: +86-755-8981 8866 Fax: +86-755-8427 6832

Email & Skype: info@chipsmall.com Web: www.chipsmall.com

Address: A1208, Overseas Decoration Building, #122 Zhenhua RD., Futian, Shenzhen, China



REV.	MODIFICATION.	DATE	DRN
01	New Drawing ECN06-246.	16/11/06	NJB
02	ECN2007-095	05/06/07	SF
03	ECN2007-147	11/09/07	TC
04	CO2010299	07/08/08	SF

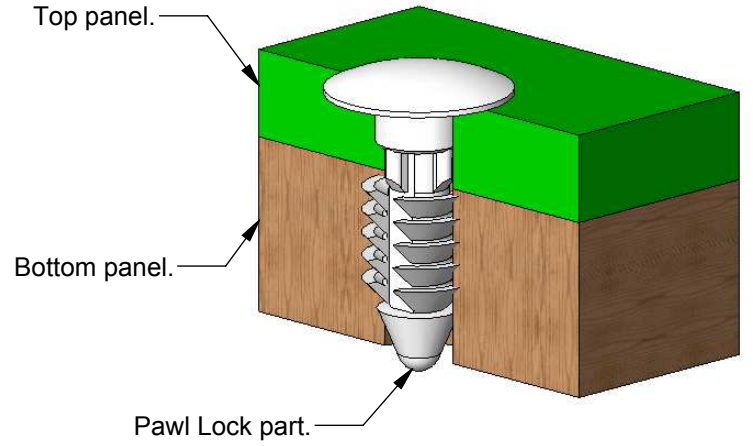

APPLICATION ASSEMBLY

NOTES

- 1a) METRIC PRIMARY UNITS: mm.
- 1b) IMPERIAL SECONDARY UNITS: [inches].
- 2) FOR USE IN A THREADED, NON-THREADED, DRILLED OR PUNCHED HOLE.

INFORMATION CONTAINED IN THIS DOCUMENT IS CONFIDENTIAL TO RICHCO INTERNATIONAL Co. Ltd. AND MAY NOT BE DISCLOSED OR REPRODUCED IN WHOLE OR PART WITHOUT THEIR WRITTEN CONSENT.



GENERAL TOLERANCES ±0.25 [0.010]
 UNLESS OTHERWISE STATED
 1 DECIMAL PLACE ±
 2 DECIMAL PLACES ±
 ANGULAR ±1°



MATERIAL: **NYLON 6/6 UL 94 V2 (RMS-01)** COLOUR: **NATURAL**

DESCRIPTION: **PAWL LOCK** PART No: **SEE TABLE**

DRG No: **06-140** NPR No: **N/A** SHEET SIZE **A4**

DRN: **NJB** DATE: **16/11/06** CHKD: **TC** DATE: **16/11/06** SCALE: **NTS** SHEET No. **1 OF 1**

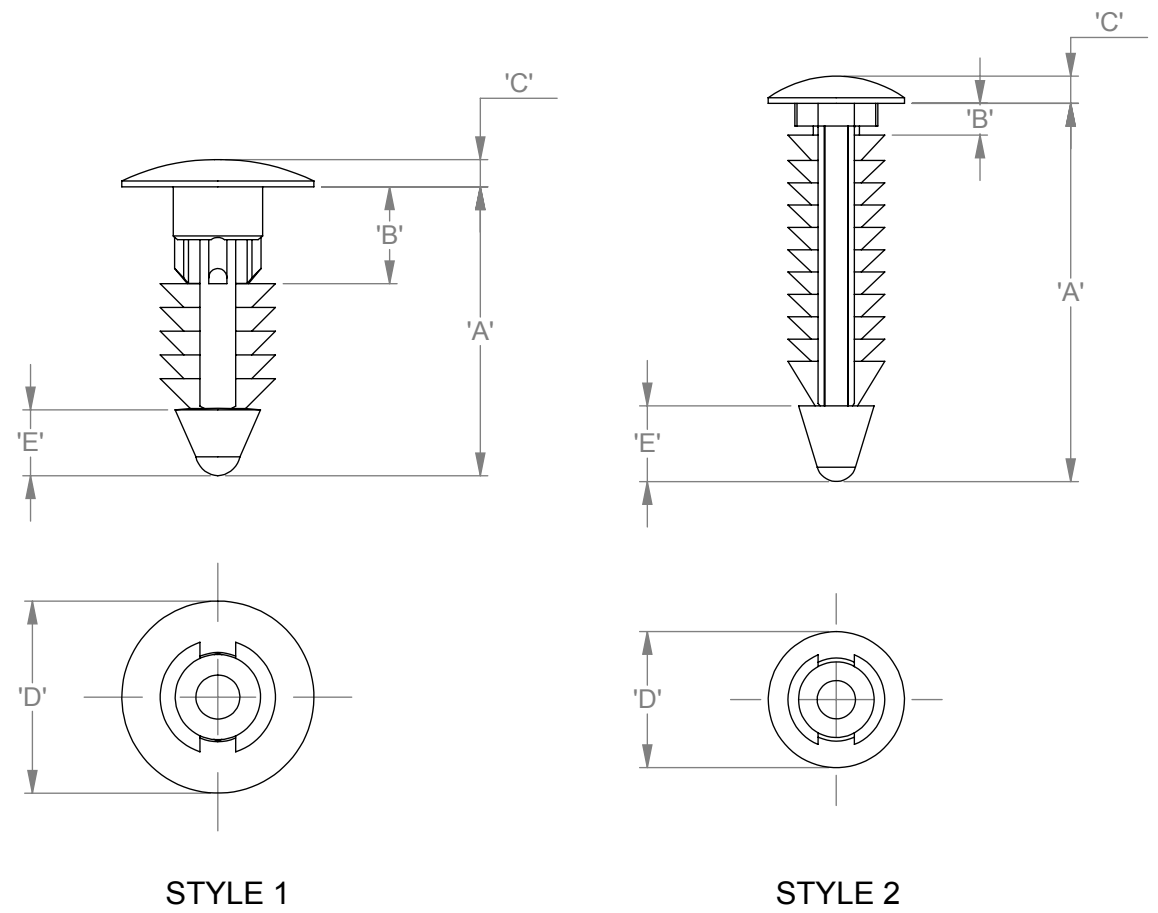

STYLE 1

STYLE 2

PART NUMBER	"A" DIM	"B" DIM	"C" DIM	"D" DIM	"E" DIM	HOLE SIZE	STYLE
PL-250-10-01	15.9[.625]	3.2[.125]	2.0[.078]	12.7[.500]	4.1[.161]	6.35[.250]	1
PL-250-12-01	19.1[.751]	6.7[.264]	1.8[.070]				
PL-250-20-01	25.0[.984]	2.1[.082]		9.0[.354]	5.0[.196]	5.5[.216]	2