



Chipsmall Limited consists of a professional team with an average of over 10 year of expertise in the distribution of electronic components. Based in Hongkong, we have already established firm and mutual-benefit business relationships with customers from,Europe,America and south Asia,supplying obsolete and hard-to-find components to meet their specific needs.

With the principle of “Quality Parts,Customers Priority,Honest Operation,and Considerate Service”,our business mainly focus on the distribution of electronic components. Line cards we deal with include Microchip,ALPS,ROHM,Xilinx,Pulse,ON,Everlight and Freescale. Main products comprise IC,Modules,Potentiometer,IC Socket,Relay,Connector.Our parts cover such applications as commercial,industrial, and automotives areas.

We are looking forward to setting up business relationship with you and hope to provide you with the best service and solution. Let us make a better world for our industry!



Contact us

Tel: +86-755-8981 8866 Fax: +86-755-8427 6832

Email & Skype: info@chipsmall.com Web: www.chipsmall.com

Address: A1208, Overseas Decoration Building, #122 Zhenhua RD., Futian, Shenzhen, China



Core **EQ38/8/25 + PLT38/25/2.7**

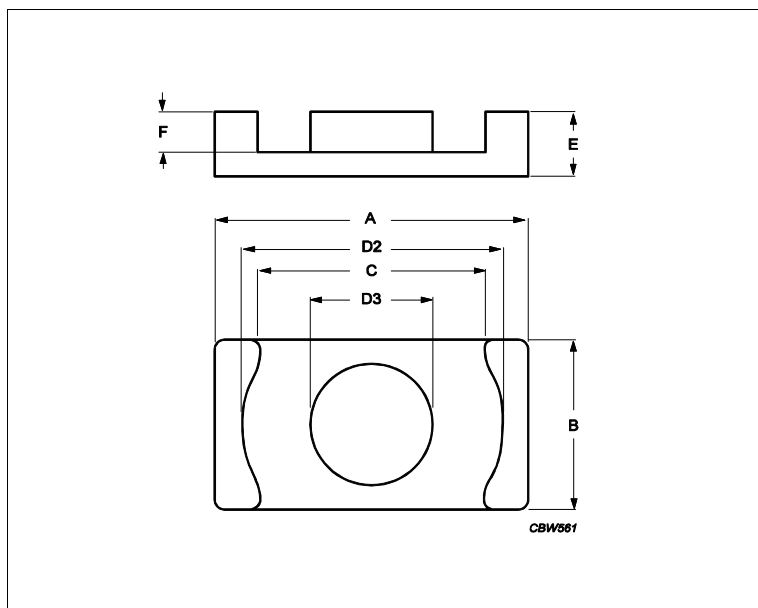

Effective parameters			
	Parameter	Value	Unit
$\Sigma(I/A)$	core factor (C1)	0.282	mm ⁻¹
Ve	effective volume	6190	mm ³
Le	effective length	41.7	mm
Ae	effective area	148	mm ²
Amin	minimum area	119	mm ²
m	EQ38/8/25	≈ 21.5	g/pcs
m	PLT38/25/2.7	≈ 14.6	g/pcs

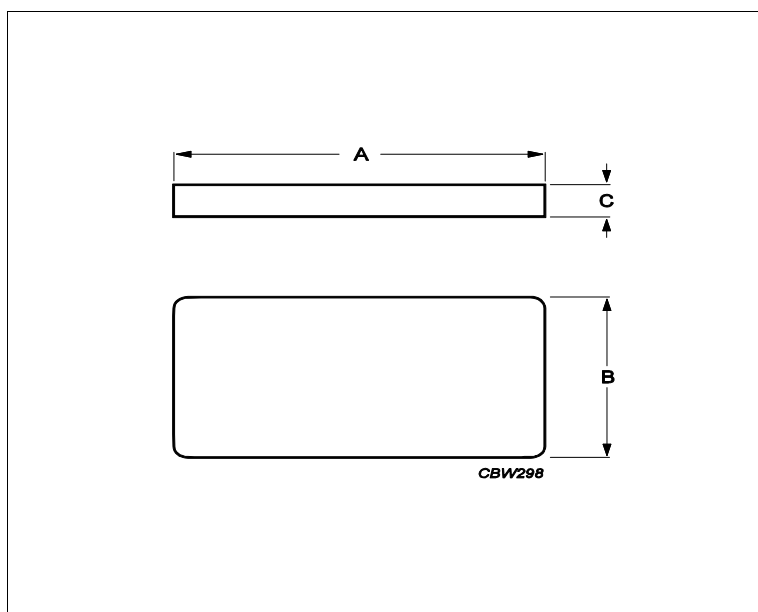

Dimensions for product: EQ38/8/25						
	Nom	Tol +	Tol -	Max	Min	Unit
A	38.10	0.70	0.70	38.80	37.40	mm
B	25.40	0.50	0.50	25.90	24.90	mm
C	24.76	0.50	0.50	25.26	24.26	mm
D2	33.10	0.60	0.60	33.70	32.50	mm
D3	14.00	0.20	0.20	14.20	13.80	mm
E	8.00	0.15	0.15	8.15	7.85	mm
F	5.30	0.20	0.20	5.50	5.10	mm
Dimensions for product: PLT38/25/2.7						
	Nom	Tol +	Tol -	Max	Min	Unit
A	38.10	0.70	0.70	38.80	37.40	mm

Core **EQ38/8/25 + PLT38/25/2.7**

Dimensions for product: PLT38/25/2.7						
	Nom	Tol +	Tol -	Max	Min	Unit
B	25.40	0.50	0.50	25.90	24.90	mm
C	2.70	0.20	0.20	2.90	2.50	mm

Inductance factor					
Material	Value	Tol +	Tol -	Unit	
3C95	9500	25%	25%	nH/turns ²	
3C96	7000	25%	25%	nH/turns ²	
3F36	4800	25%	25%	nH/turns ²	
3F4	3500	25%	25%	nH/turns ²	

Power loss: 3C95				
Measuring conditions			Max	Unit
100 kHz	200 mT	100 °C	3.000	W/set
100 kHz	200 mT	25 °C	3.200	W/set

Power loss: 3C96				
Measuring conditions			Max	Unit
100 kHz	200 mT	100 °C	2.800	W/set
400 kHz	50 mT	100 °C	1.100	W/set

Power loss: 3F36				
Measuring conditions			Max	Unit
500 kHz	50 mT	100 °C	0.930	W/set
500 kHz	100 mT	100 °C	7.100	W/set

Power loss: 3F4				
Measuring conditions			Max	Unit
1000 kHz	30 mT	100 °C	1.900	W/set
3000 kHz	10 mT	100 °C	3.100	W/set

Bsat					
Measuring conditions			Material	Min	Unit
25 kHz	250 A/m	100 °C	3C95	330	mT
25 kHz	250 A/m	100 °C	3C96	340	mT
25 kHz	250 A/m	100 °C	3F36	340	mT
25 kHz	250 A/m	100 °C	3F4	330	mT