



Chipsmall Limited consists of a professional team with an average of over 10 year of expertise in the distribution of electronic components. Based in Hongkong, we have already established firm and mutual-benefit business relationships with customers from,Europe,America and south Asia,supplying obsolete and hard-to-find components to meet their specific needs.

With the principle of “Quality Parts,Customers Priority,Honest Operation,and Considerate Service”,our business mainly focus on the distribution of electronic components. Line cards we deal with include Microchip,ALPS,ROHM,Xilinx,Pulse,ON,Everlight and Freescale. Main products comprise IC,Modules,Potentiometer,IC Socket,Relay,Connector.Our parts cover such applications as commercial,industrial, and automotives areas.

We are looking forward to setting up business relationship with you and hope to provide you with the best service and solution. Let us make a better world for our industry!



## Contact us

Tel: +86-755-8981 8866 Fax: +86-755-8427 6832

Email & Skype: info@chipsmall.com Web: www.chipsmall.com

Address: A1208, Overseas Decoration Building, #122 Zhenhua RD., Futian, Shenzhen, China





## Standard PM Step Motors

# PM42L-048-HHC9

Step Angle: 7.5°

### Model Specifications

Model:	PM42L-048-HHC9
Shaft Length:	12mm
Wire Length:	300mm fly lead (no connector)
Wire Holder:	90 deg. Left
Front Plate:	FPH
Electrical:	24V, 600mA
	Bipolar Constant Current
	7 ohms, MS70M

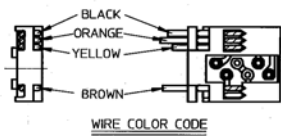

WIRE COLOR	MOTOR
BLACK	A1
BROWN	A3
ORANGE	B1
YELLOW	B3

COLOR	BLACK	ORANGE	BROWN	YELLOW
STEP				
1	-	+	+	-
2	-	-	+	+
3	+	-	-	+
4	+	+	-	-

SWITCHING SEQUENCE  
(VIEWED FROM MOUNTING SURFACE)

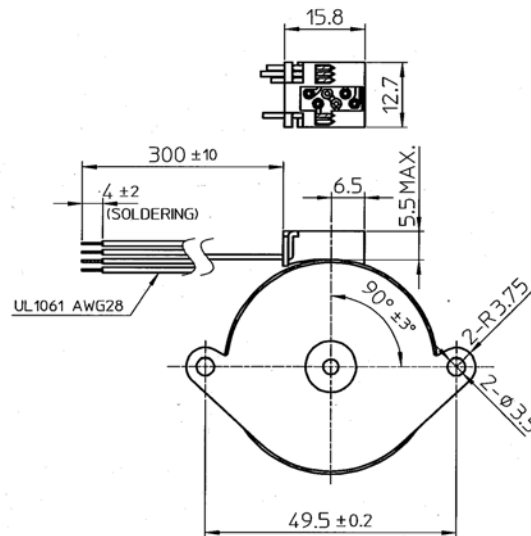

### MARKING

NMB-MAT PM42L-048-HHC9
JAPAN H9817
<JAPAN>

NMB-MAT PM42L-048-HHC9
THAILAND TA9817
<THAILAND>

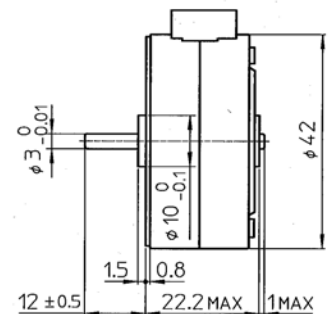

## Standard PM Step Motors

# PM42L-048-HHC9

### DYNAMIC TORQUE CHARACTERISTICS (No. 62796) (ALL VALUES ARE GAINED BY MEASUREMENT AND NOT SPECIFICATIONS VALUES)

Model : PM42L-048-HHC9  
 Drive Mode : BIPOLAR CHOPPER  
 Drive Voltage : 24.0 V  
 Method : 2-2P  
 Drive IC : UDN2917EB  
 Surge/Current : / 600 mA / Phase (Peak)  
 Coil Resistance : 7.0 Ω  
 Magnet Material : MS70M  
 Stator Material : SECC

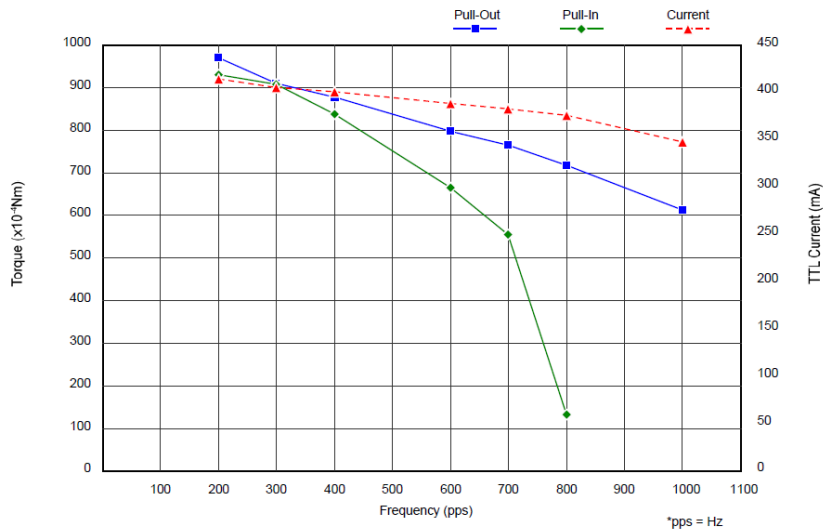

(TTL Current = Over all current drawn by the driver)

Frequency (pps)	200	300	400	600	700	800	1000
■ Pull-Out (x10 <sup>-4</sup> Nm)	968.0	909.1	875.8	796.3	764.0	716.9	611.0
◆ Pull-In (x10 <sup>-4</sup> Nm)	928.7	906.2	837.5	663.9	553.1	131.4	
▲ Current (mA)	414	405	400	388	382	375	347

Minebea Motor Manufacturing Corporation