



Chipsmall Limited consists of a professional team with an average of over 10 year of expertise in the distribution of electronic components. Based in Hongkong, we have already established firm and mutual-benefit business relationships with customers from,Europe,America and south Asia,supplying obsolete and hard-to-find components to meet their specific needs.

With the principle of “Quality Parts,Customers Priority,Honest Operation,and Considerate Service”,our business mainly focus on the distribution of electronic components. Line cards we deal with include Microchip,ALPS,ROHM,Xilinx,Pulse,ON,Everlight and Freescale. Main products comprise IC,Modules,Potentiometer,IC Socket,Relay,Connector.Our parts cover such applications as commercial,industrial, and automotives areas.

We are looking forward to setting up business relationship with you and hope to provide you with the best service and solution. Let us make a better world for our industry!



Contact us

Tel: +86-755-8981 8866 Fax: +86-755-8427 6832

Email & Skype: info@chipsmall.com Web: www.chipsmall.com

Address: A1208, Overseas Decoration Building, #122 Zhenhua RD., Futian, Shenzhen, China



ITEM	Q'TY	PART NUMBER	PART DESCRIPTION
1	1	FLP-LC2	LENS CAP, FLEXIBLE LIGHT-PIPE, 5mm ROUND
2	1	FLPS2031-XX.X	2mm LIGHT PIPE CABLE, CUT LENGTH IN INCHES

REV.	DESCRIPTION	DATE	APPROVED
A	Engineering Release	04/20/12	T. Y.

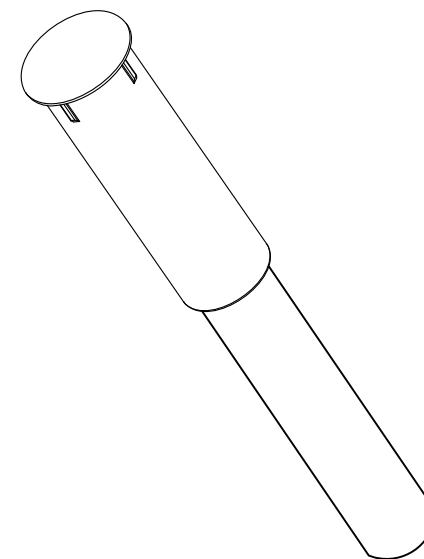
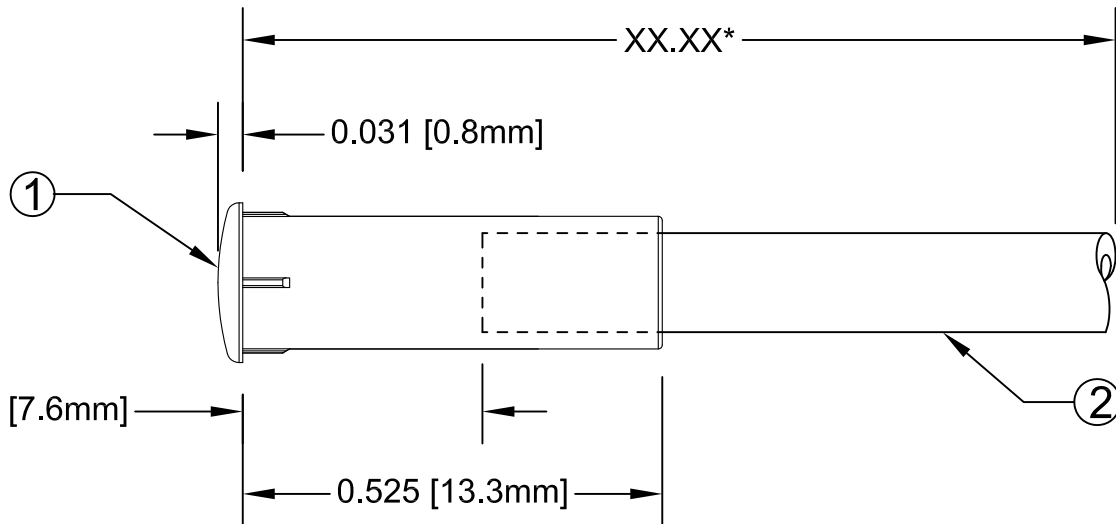
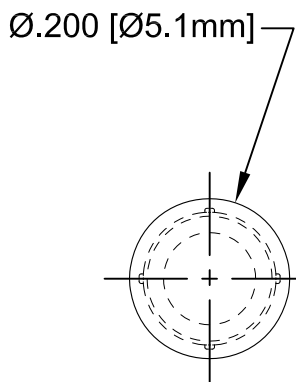

*Length "XX.XX"	Tolerance
2.50" ~ 16.00"	±0.050"
16.25" ~ 40.00"	±0.15"
40.25" ~ 80.00"	±0.30"
80.25" ~ 500.0"	±0.5%

EXAMPLE:
PM5-C2031-6.50

Series | Fiber Length in 0.25" Increments

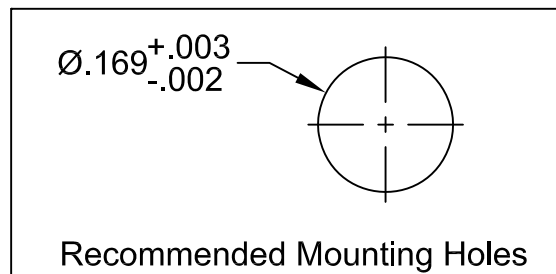

STANDARD TOLERANCE (UNLESS OTHERWISE SPECIFIED)		 4 THOMAS, IRVINE, CA. 92618 TEL: (949) 951-8808 FAX: (949) 951-3974
DECIMALS	ANGULAR	
.X ±.1	X° ± 1°	TITLE: 5mm Circular Lens Flexible Light Pipe FLPS2031 Indicator PART NO: PM5-C2031-XX.XX REVISION: A CAGE CODE : 32559 SHEET # 1 OF 1 <small>CAD GENERATED DOCUMENT, DO NOT MEASURE DRAWING.</small>
.XX ±.02		
.XXX ±.010		
DESIGNED: Ty Yin	DATE: 04/20/12	PART NO: PM5-C2031-XX.XX REVISION: A
CHECKED: B. Oliver	DATE: 04/20/12	