



Chipsmall Limited consists of a professional team with an average of over 10 year of expertise in the distribution of electronic components. Based in Hongkong, we have already established firm and mutual-benefit business relationships with customers from,Europe,America and south Asia,supplying obsolete and hard-to-find components to meet their specific needs.

With the principle of “Quality Parts,Customers Priority,Honest Operation,and Considerate Service”,our business mainly focus on the distribution of electronic components. Line cards we deal with include Microchip,ALPS,ROHM,Xilinx,Pulse,ON,Everlight and Freescale. Main products comprise IC,Modules,Potentiometer,IC Socket,Relay,Connector.Our parts cover such applications as commercial,industrial, and automotives areas.

We are looking forward to setting up business relationship with you and hope to provide you with the best service and solution. Let us make a better world for our industry!



Contact us

Tel: +86-755-8981 8866 Fax: +86-755-8427 6832

Email & Skype: info@chipsmall.com Web: www.chipsmall.com

Address: A1208, Overseas Decoration Building, #122 Zhenhua RD., Futian, Shenzhen, China



PMT Panel Mount Power Supply

24V 50W 1 Phase / PMT-24V50W1A□

PMT

Highlights & Features

- Universal AC input range
- Power will not de-rate from input voltage 90Vac to 264Vac
- High MTBF > 700,000 hrs. per Telcordia SR-332
- Short Circuit / Overvoltage / Overload / Over Temperature Protections
- Versatile connector options (Terminal Block, Front Face, Harness)



Safety Standards



CB Certified for worldwide use

Model Number: PMT-24V50W1A□
Unit Weight: 0.24 kg (0.53 lb)
Dimensions (L x W x D): 98 x 98 x 38 mm
 (3.86 x 3.86 x 1.50 inch)

General Description

The new PMT series of panel mount power supplies is the latest offering from one of the world's largest power supply manufacturers and solution providers - Delta. The first range of PMT products will offer a nominal output voltage of 24V with a wide operating temperature range from -10°C to +70°C and can withstand shock and vibration requirements (in accordance to IEC 60068-2-27 and IEC 60068-2-6 respectively). In addition to features like overvoltage and overload protections, Delta's PMT series of panel mount power supplies is unlike many other brands in the same price level. The PMT series is designed for cost competitive markets without compromising the quality of the components and product specifications. The series of products has an expected life time of 10 years and will have no output power de-rating from 90Vac to 264Vac. This versatile series has three different connector options (Terminal Block, Front Face and Harness) and can also be converted into L Frame (PML) or Open Frame (PMB) type of power supplies to satisfy different application needs.

Model Information

PMT Panel Mount Power Supply

| Model Number | Input Voltage Range | Rated Output Voltage | Rated Output Current |
|---------------|---------------------|----------------------|----------------------|
| PMT-24V50W1A□ | 85-264Vac | 24Vdc | 2.09A |

Model Numbering

| | | | | | | | CC Code** |
|-------------|---|----------------|--------------|--------------|----------|---|---|
| PM | □ – | 24V | 50W | 1 | A | □ | □ |
| Panel Mount | Product Type T – Enclosed L – L Frame* B – Open Frame* | Output Voltage | Output Power | Single Phase | No PFC | Connector Type A – Terminal Block G – Front Face* H – Harness* | Blank – Without connector cover A – With connector cover B – With conformal coating |

*Options

**For Enclosed type with Terminal Block

PMT Panel Mount Power Supply

24V 50W 1 Phase / PMT-24V50W1A□

Specifications

Input Ratings / Characteristics

| | |
|---------------------------------|------------------------------------|
| Nominal Input Voltage | 100-240Vac |
| Input Voltage Range | 85-264Vac |
| Nominal Input Frequency | 50-60Hz |
| Input Frequency Range | 47-63Hz |
| Input Current | < 1.10A @ 115Vac, < 0.65A @ 230Vac |
| Efficiency at 100% Load | > 86.0% @ 115Vac & 230Vac |
| Max Power Dissipation | 0% load |
| | 100% load |
| Max Inrush Current (Cold Start) | < 30A @ 115Vac, < 60A @ 230Vac |
| Leakage Current | < 1mA @ 240Vac |

Output Ratings / Characteristics*

| | |
|--|--|
| Nominal Output Voltage | 24Vdc |
| Factory Set Point Tolerance | 24Vdc \pm 2% |
| Output Voltage Adjustment Range | 22-28Vdc |
| Output Current | 2.09A |
| Output Power | 50W |
| Line Regulation | < 0.5% typ. (@ 85-264Vac input, 100% input) |
| Load Regulation | < 1% typ. (@ 85-264Vac input, 0-100% input) |
| PARD** (20MHz) | < 100mVpp @ 0°C to 50°C, < 150mVpp @ -10°C to 0°C |
| Rise Time | < 30ms @ nominal input (100% load) |
| Start-up Time | < 2500ms @ nominal input (100% load) |
| Hold-up Time | > 16.7ms @ 115Vac (100% load) |
| Dynamic Response (Overshoot & Undershoot O/P Voltage) | \pm 5% @ 0-100% load (Slew Rate: 0.1A/ μ S) |
| Start-up with Capacitive Loads | 8,000 μ F Max |

*For power de-rating from 50°C to 70°C, see power de-rating on page 3.

**PARD is measured with an AC coupling mode, 5cm wires, and in parallel with 0.1 μ F ceramic capacitor & 47 μ F electrolytic capacitor.

PMT Panel Mount Power Supply

24V 50W 1 Phase / PMT-24V50W1A□

Mechanical

| | | |
|-----------------------------------|---|---|
| Case Chassis / Cover | Aluminium / SGCC | |
| Dimensions (L x W x D) | 98 x 98 x 38 mm (3.86 x 3.86 x 1.50 inch) | |
| Unit Weight | 0.24 kg (0.53 lb) | |
| Indicator | Green LED (DC OK) | |
| Cooling System | Convection | |
| Terminal | PM□-24V50W1AA□ | M3.5 x 5 Pins (Rated 300V/15A) |
| | PM□-24V50W1AG□ | M3.5 x 5 Pins (Rated 300V/20A) |
| | PM□-24V50W1AH□ | I/P (JST): B3P5-VH(LF)(SN) O/P (JST): B2P3-VH(LF)(SN) |
| Wire | PM□-24V50W1AA□ | AWG 22-12 |
| | PM□-24V50W1AG□ | AWG 22-12 |
| | PM□-24V50W1AH□ | AWG 22-18 (For the recommended Housing and Terminal, please refer to the Table on Page 8) |
| Noise (1 Meter from power supply) | Sound Pressure Level (SPL) < 25dBA | |

Environment

| | | |
|-----------------------------|--|----------------|
| Surrounding Air Temperature | Operating | -10°C to +70°C |
| | Storage | -25°C to +85°C |
| Power De-rating | > 50°C de-rate power by 2.5% / °C | |
| Operating Humidity | 5 to 95% RH (Non-Condensing) | |
| Operating Altitude | 0 to 5,000 Meters (16,400 ft.) | |
| Shock Test (Non-Operating) | IEC 60068-2-27, Half Sine Wave: 50G for a duration of 11ms, 3 shocks for each 3 directions | |
| Vibration (Non-Operating) | IEC 60068-2-6, Random: 5Hz to 500Hz (2.09Grms); 20 min per axis for all X, Y, Z direction | |
| Pollution Degree | 2 | |

Protections

| | |
|--------------------------|---|
| Overvoltage | < 32V, ±10%, SELV Output, Hiccup Mode, Non-Latching (Auto-Recovery) |
| Overload / Overcurrent | > 120% of rated load current, Hiccup Mode, Non-Latching (Auto-Recovery) |
| Over Temperature | Non-Latching (Auto-Recovery) |
| Short Circuit | Hiccup Mode, Non-Latching (Auto-Recovery when the fault is removed) |
| Internal Fuse | T3.15AH |
| Protection Against Shock | Class I with PE* connection |

*PE: Primary Earth

PMT Panel Mount Power Supply

24V 50W 1 Phase / PMT-24V50W1A□

Reliability Data

| | |
|------------------------|--|
| MTBF | > 700,000 hrs. as per Telcordia SR-332 I/P: 100Vac, O/P: 100% Load, Ta: 35°C) |
| Expected Cap Life Time | 10 years (115Vac & 230Vac, 50% load @ 40°C) |

Safety Standards / Directives

| | | |
|--------------------------|---|--|
| Safety Entry Low Voltage | | SELV (EN 60950-1) |
| Electrical Safety | TUV Bauart UL/cUL recognized CB Scheme CCC | EN 60950-1 UL 60950-1 and CSA C22.2 No. 60950-1 (File No. E131881) IEC 60950-1 GB4943 |
| CE | | In conformance with EMC Directive 2014/30/EU and Low Voltage Directive 2014/35/EU |
| Material and Parts | | RoHS Directive 2011/65/EU Compliant |
| Galvanic Isolation | Input to Output | 3.0KVac |
| | Input to Ground | 1.5KVac |
| | Output to Ground | 0.5KVac |

EMC

| | | |
|-----------------------------------|----------------|--|
| Emissions (CE & RE) | | CISPR 22, EN 55022, FCC Title 47: Class B |
| Immunity | | EN 55024 |
| Electrostatic Discharge | IEC 61000-4-2 | Level 4 Criteria A ¹⁾ Air Discharge: 15kV Contact Discharge: 8kV |
| Radiated Field | IEC 61000-4-3 | Level 3 Criteria A ¹⁾ 80MHz-1GHz, 10V/M with 1kHz tone / 80% modulation |
| Electrical Fast Transient / Burst | IEC 61000-4-4 | Level 3 Criteria A ¹⁾ 2kV |
| Surge | IEC 61000-4-5 | Level 3 Criteria A ¹⁾ Common Mode ²⁾ : 2kV Differential Mode ³⁾ : 1kV |
| Conducted | IEC 61000-4-6 | Level 3 Criteria A ¹⁾ 150kHz-80MHz, 10Vrms |
| Power Frequency Magnetic Fields | IEC 61000-4-8 | Criteria A ¹⁾ 10A/Meter |
| Voltage Dips | IEC 61000-4-11 | 100% dip; 1 cycle (20ms); Self Recoverable |
| Low Energy Pulse Test (Ring Wave) | IEC 61000-4-12 | Level 3 Criteria A ¹⁾ Common Mode ²⁾ : 2kV Differential Mode ³⁾ : 1kV |

1) Criteria A: Normal performance within the specification limits

2) Asymmetrical: Common mode (Line to earth)

3) Symmetrical: Differential mode (Line to line)

PMT Panel Mount Power Supply

24V 50W 1 Phase / PMT-24V50W1A□

Block Diagram

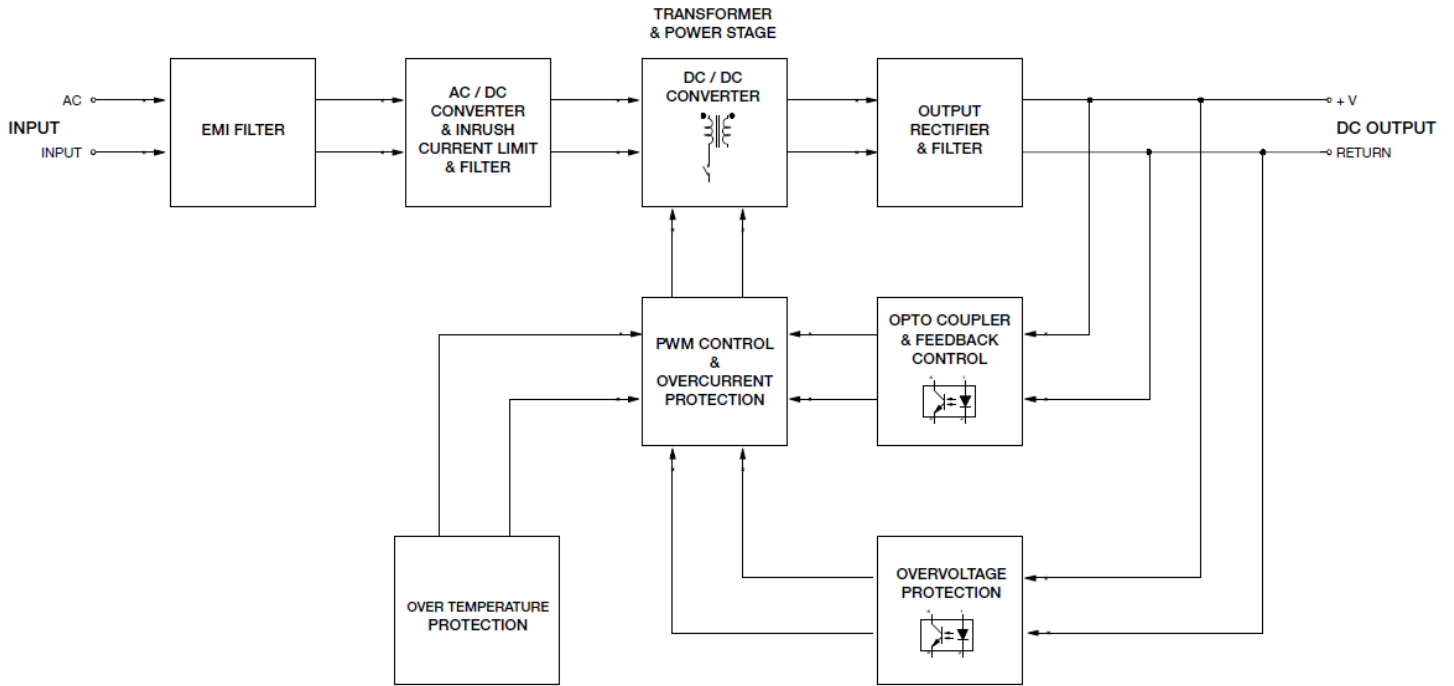

Device Descriptions

| PMT-24V50W1AA□: Terminal Block | PMT-24V50W1AG: Front Face | PMT-24V50W1AH: Harness |
|--------------------------------|---------------------------|------------------------|
| | | |

PMT Panel Mount Power Supply

24V 50W 1 Phase / PMT-24V50W1A□

Dimensions

PMT-24V50W1AA□: Terminal Block

L x W x D: 98 x 98 x 38 mm (3.86 x 3.86 x 1.50 inch)

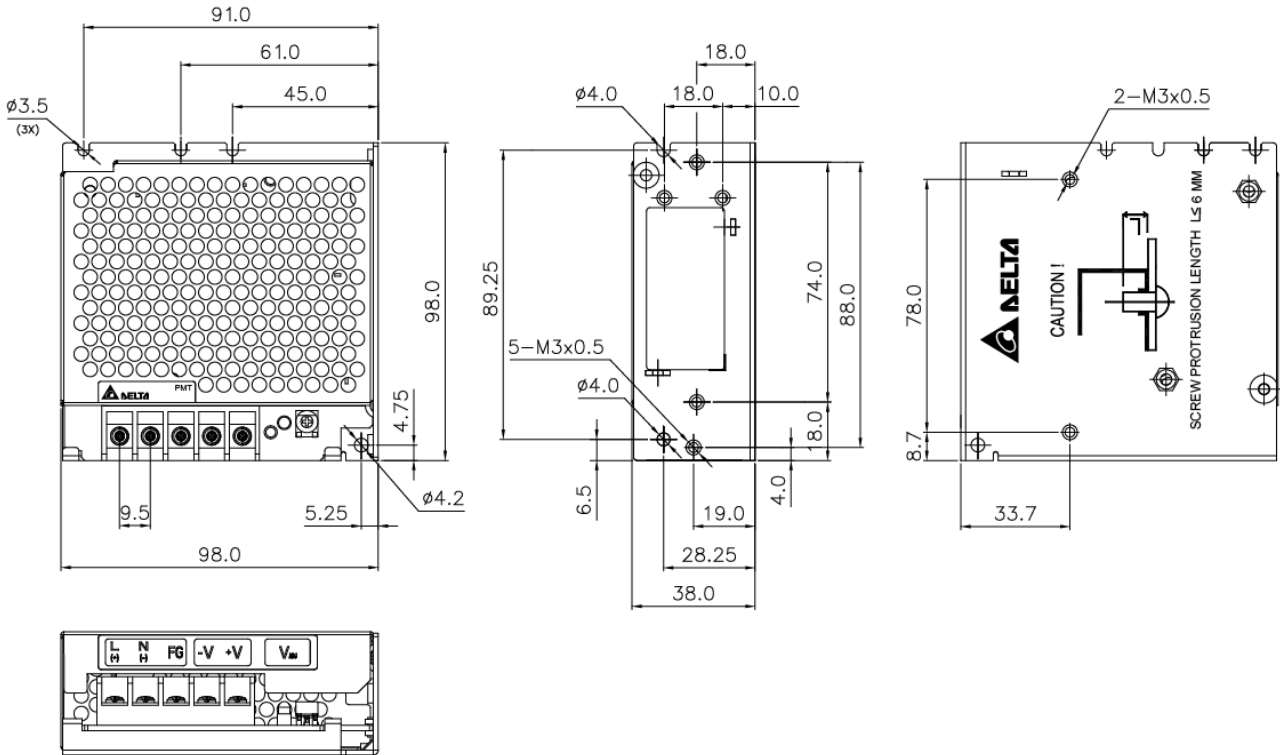

PMT-24V50W1AG: Front Face

L x W x D: 98 x 98 x 38 mm (3.86 x 3.86 x 1.50 inch)

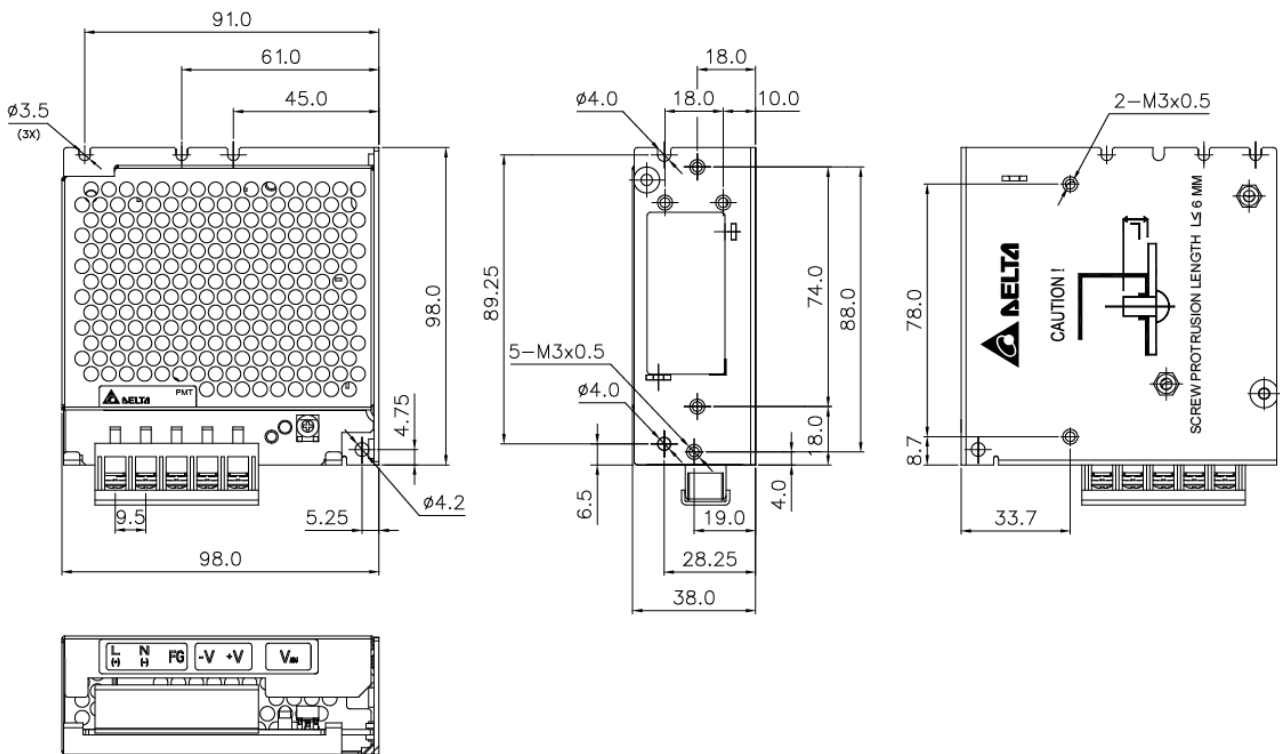

PMT Panel Mount Power Supply

24V 50W 1 Phase / PMT-24V50W1A□

PMT-24V50W1AH: Harness

L x W x D: 98 x 98 x 38 mm (3.86 x 3.86 x 1.50 inch)

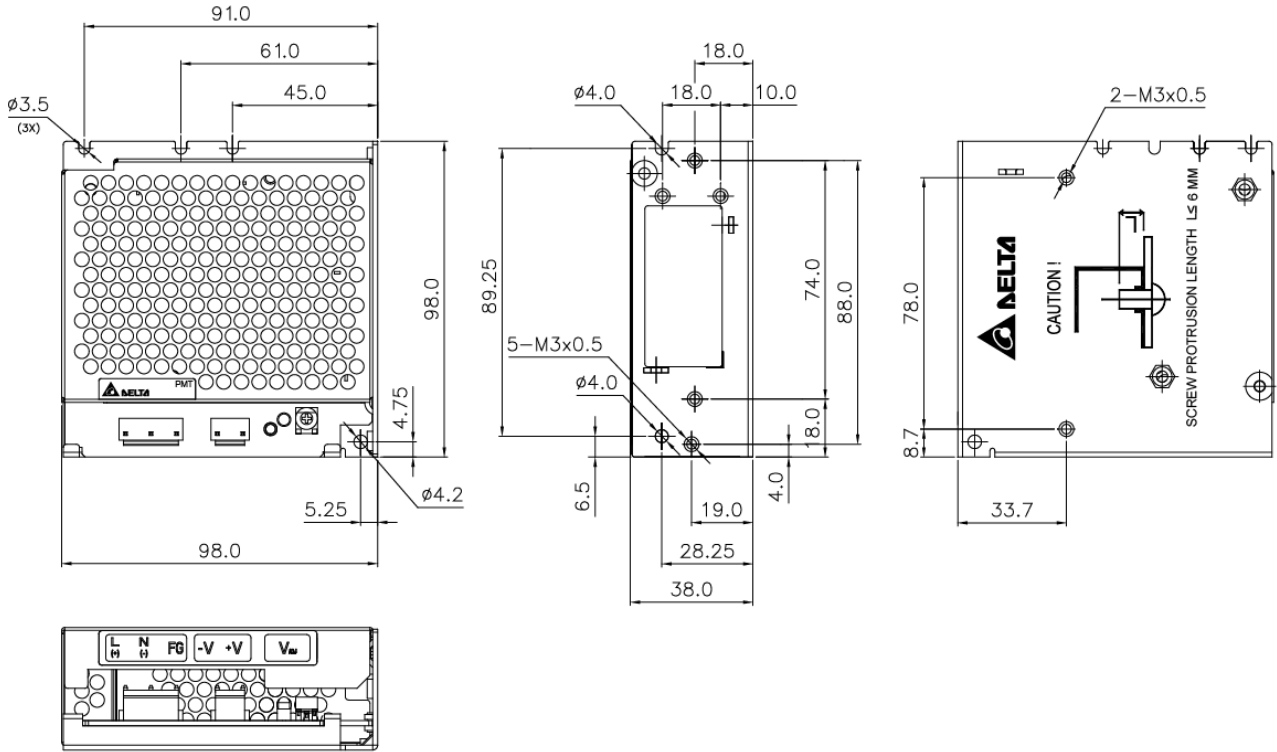

PML-24V50W1AA: Terminal Block

L x W x D: 98 x 98 x 37.5 mm (3.86 x 3.86 x 1.48 inch)

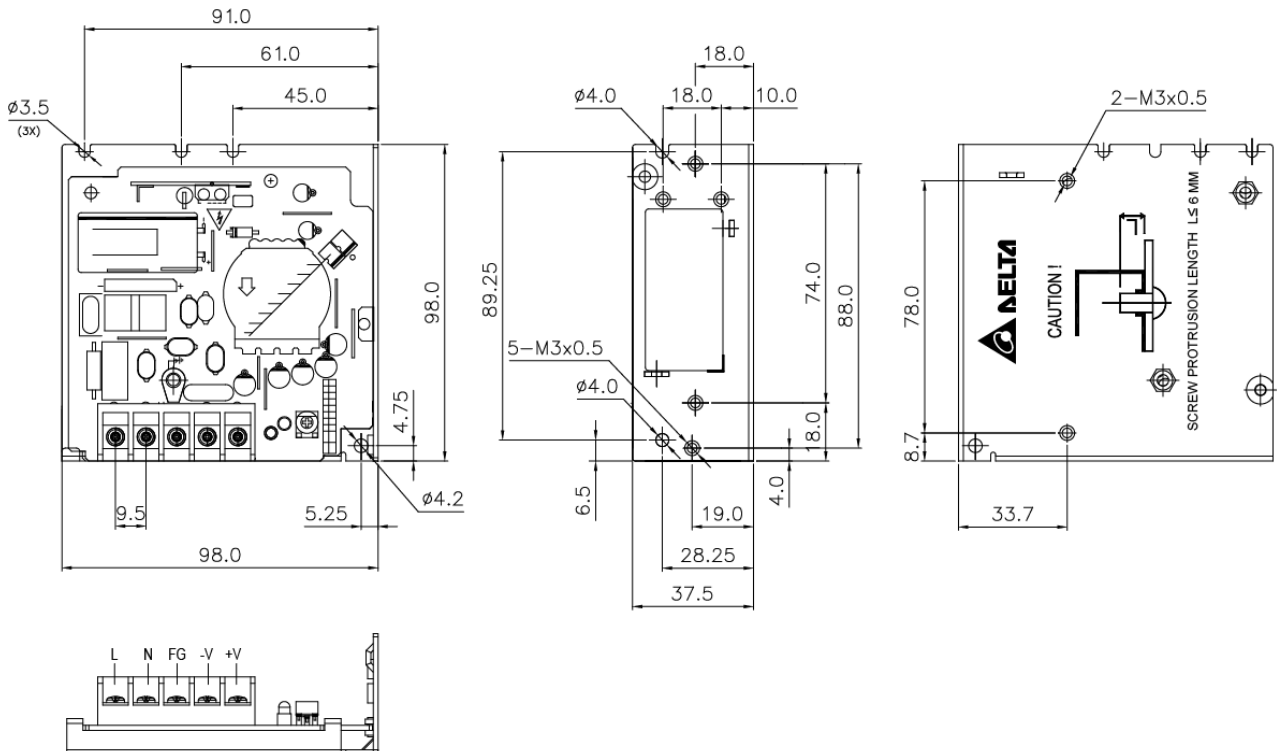

PMT Panel Mount Power Supply

24V 50W 1 Phase / PMT-24V50W1A□

PML-24V50W1AG: Front Face

L x W x D: 98 x 98 x 37.5 mm (3.86 x 3.86 x 1.48 inch)

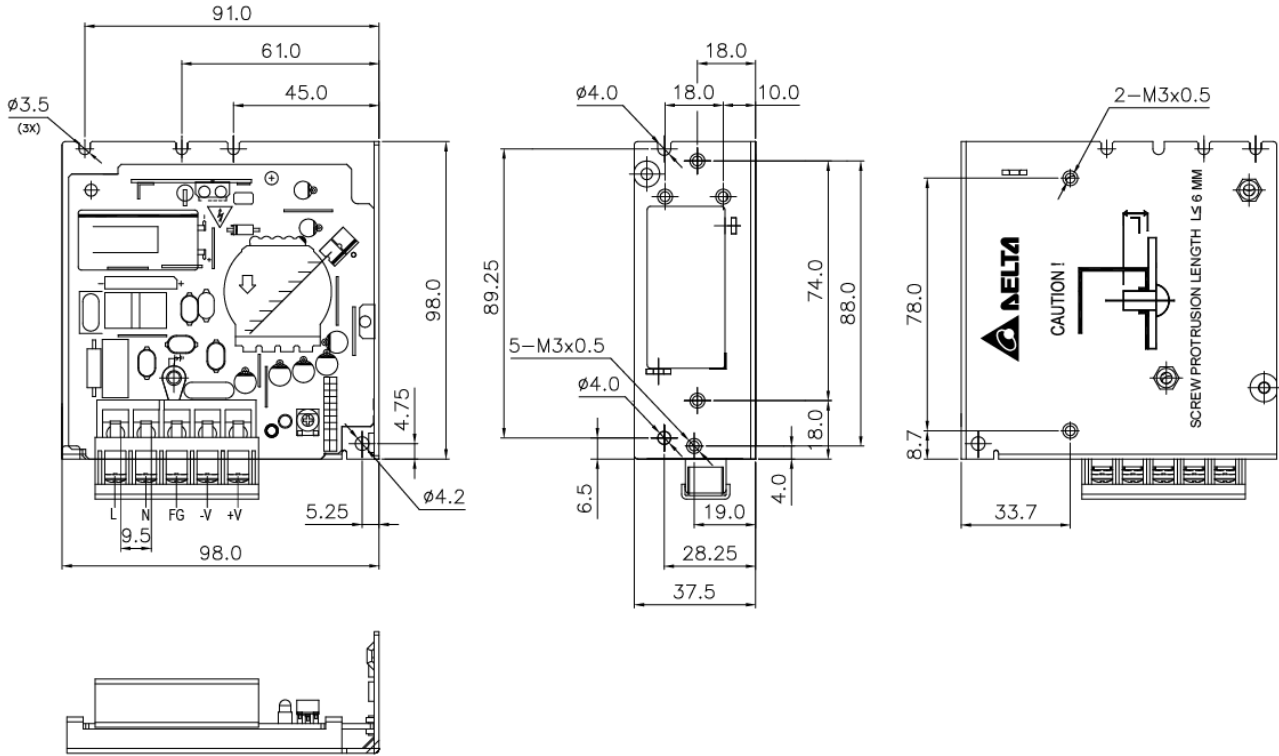

PML-24V50W1AH: Harness

L x W x D: 98 x 98 x 37.5 mm (3.86 x 3.86 x 1.48 inch)

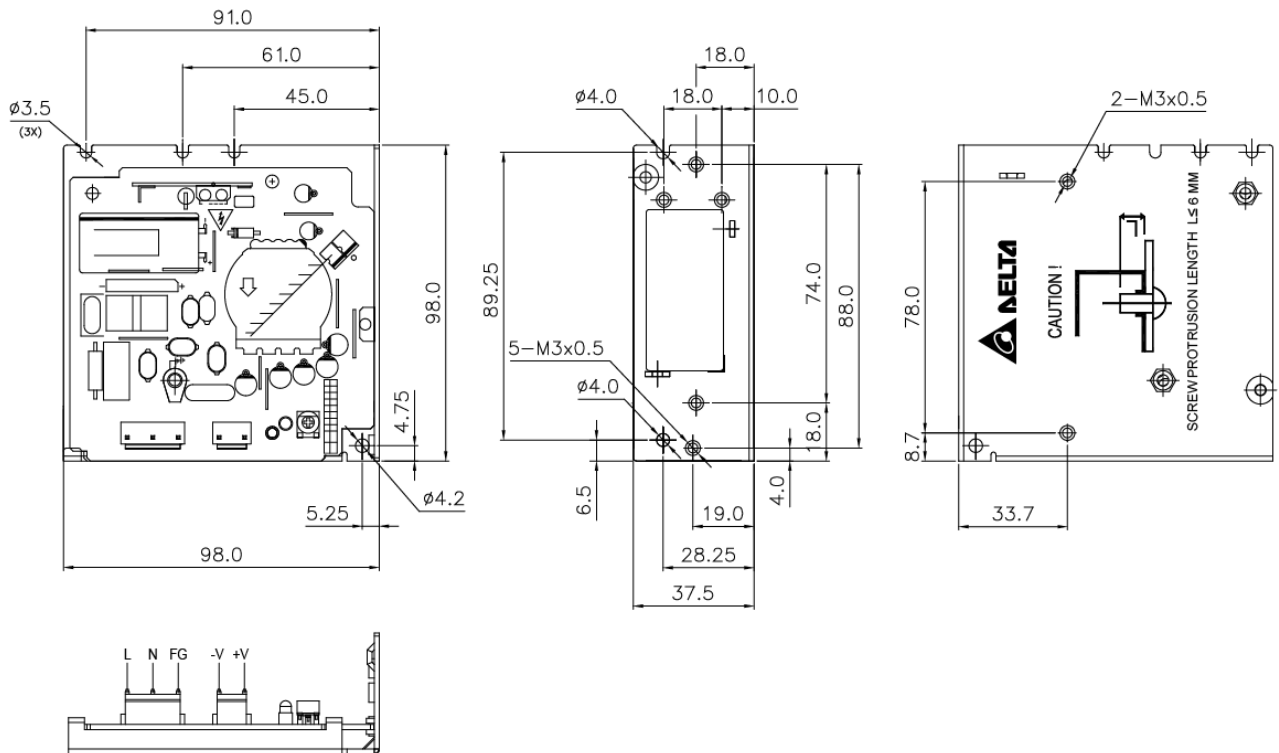

PMT Panel Mount Power Supply

24V 50W 1 Phase / PMT-24V50W1A□

PMB-24V50W1AA: Terminal Block

L x W x D: 91 x 94.3 x 30.6 mm (3.58 x 3.71 x 1.20 inch)

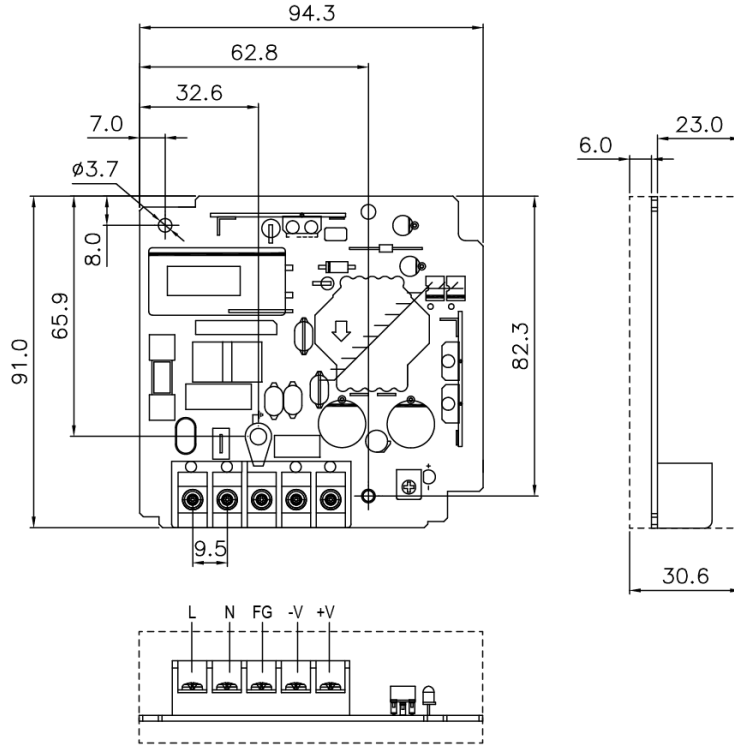

PMB-24V50W1AG: Front Face

L x W x D: 91 x 94.3 x 30.6 mm (3.58 x 3.71 x 1.20 inch)

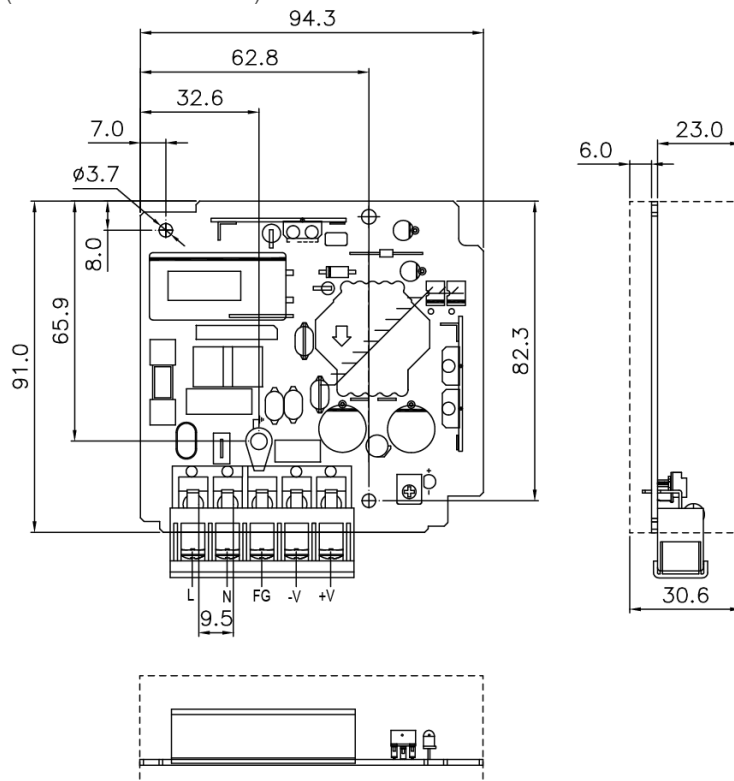

PMT Panel Mount Power Supply

24V 50W 1 Phase / PMT-24V50W1A□

PMB-24V50W1AH: Harness

L x W x D: 91 x 94.3 x 30.6 mm (3.58 x 3.71 x 1.20 inch)

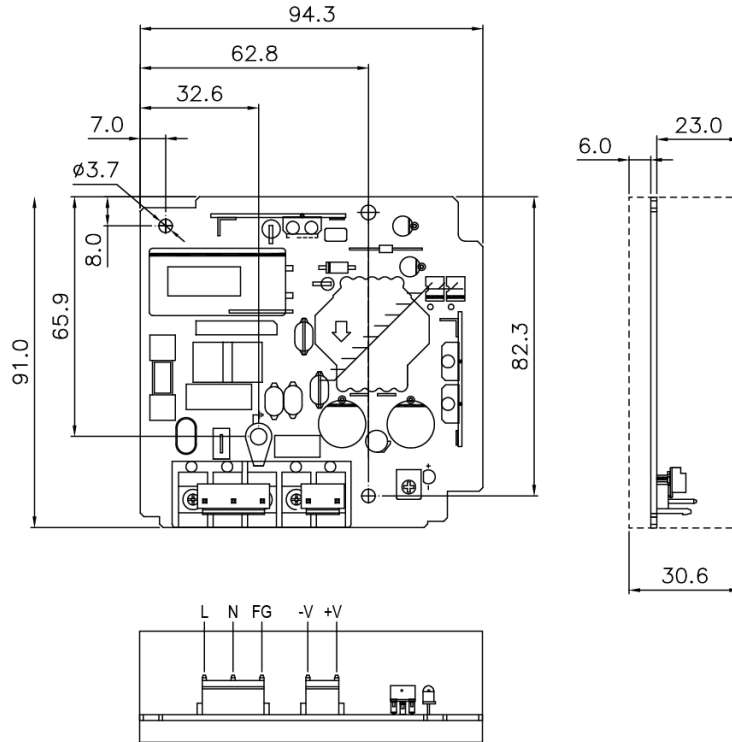

PMT Panel Mount Power Supply

24V 50W 1 Phase / PMT-24V50W1A□

Engineering Data

Output Load De-rating VS Surrounding Air Temperature

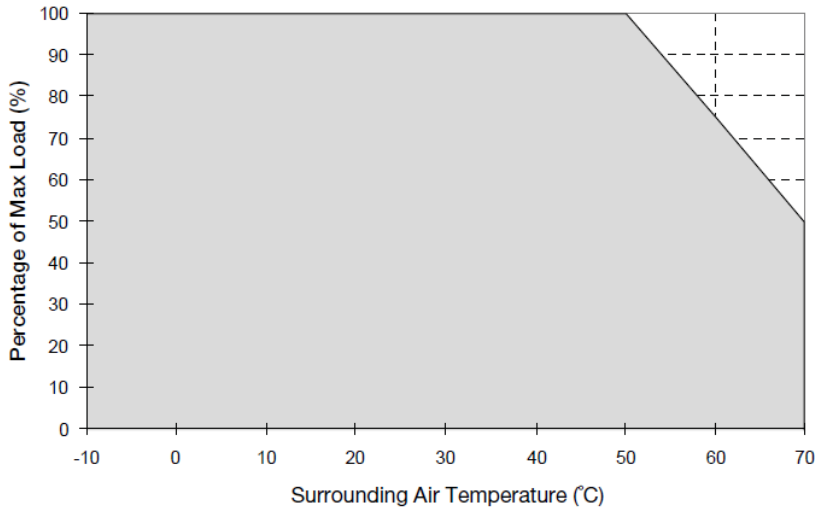
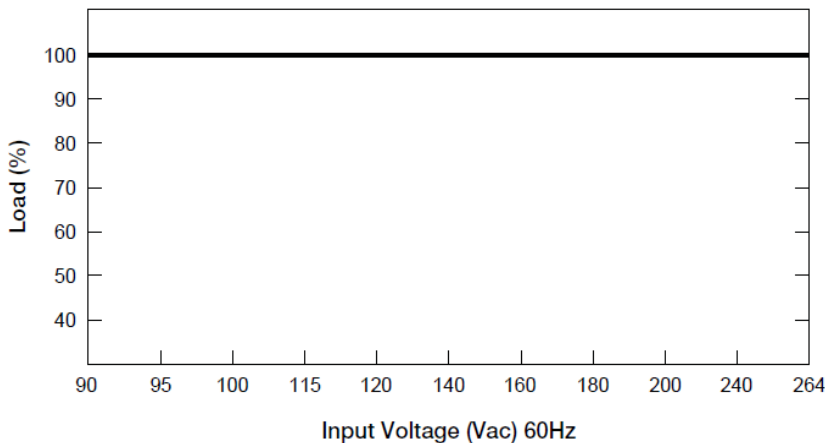

Fig. 1 De-rating for Vertical and Horizontal Mounting Orientation
 > 50°C de-rate power by 2.5% / °C

Note

1. Power supply components may degrade, or be damaged, when the power supply is continuously used outside the shaded region, refer to the graph shown in Fig. 1.
2. If the output capacity is not reduced when the surrounding air temperature >50°C, the device will run into Over Temperature Protection. When activated, the output voltage will go into bouncing mode and will recover when the surrounding air temperature is lowered or the load is reduced as far as necessary to keep the device in working condition.
3. In order for the device to function in the manner intended, it is also necessary to keep a safety distance of 20 mm (0.79 inch) with adjacent units while the device is in operation.
4. Depending on the surrounding air temperature and output load delivered by the power supply, the device can be very hot!
5. If the device has to be mounted in any other orientation, please contact info@deltapsu.com for more details.

Output Load De-rating VS. Input Voltage



- No output power de-rating for the input voltage from 90Vac to 264Vac

PMT Panel Mount Power Supply

24V 50W 1 Phase / PMT-24V50W1A□

Assembly & Installation

- Ⓐ Mounting holes for power supply (device). The power supply shall be mounted on minimum 2 mounting holes using M3 screw minimum 5mm (0.20 inch) length.
- Ⓑ This surface belongs to customer's end system or panel where the power supply is mounted.
- Ⓒ Connector

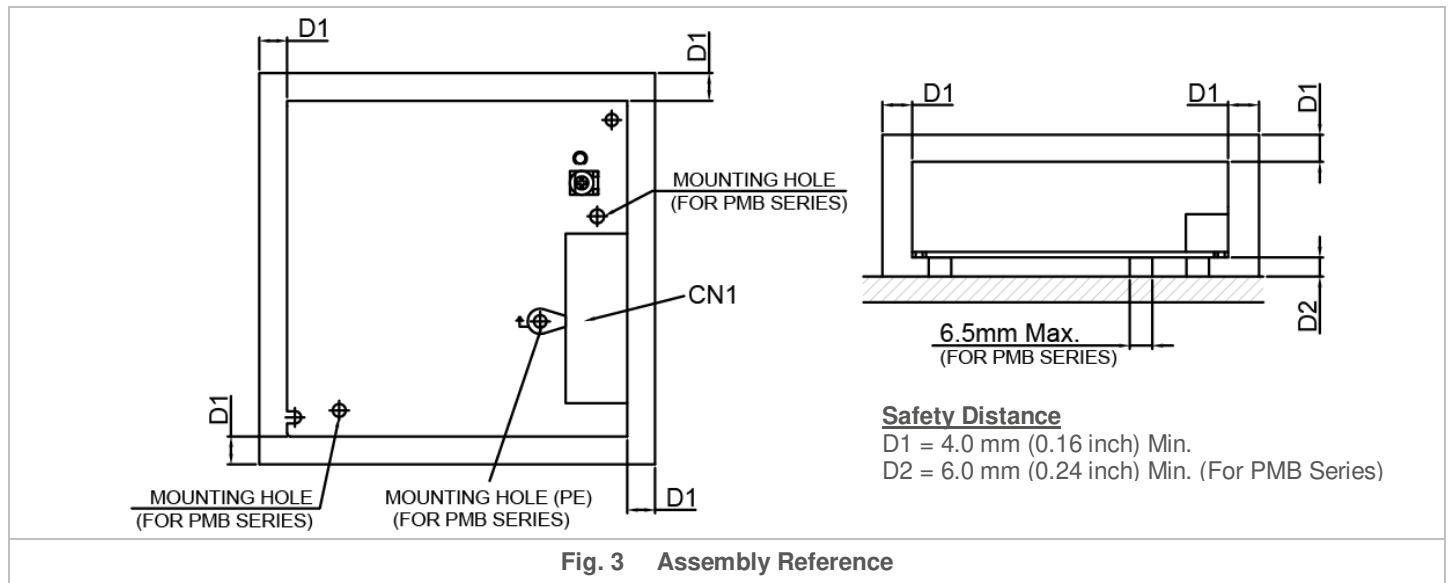
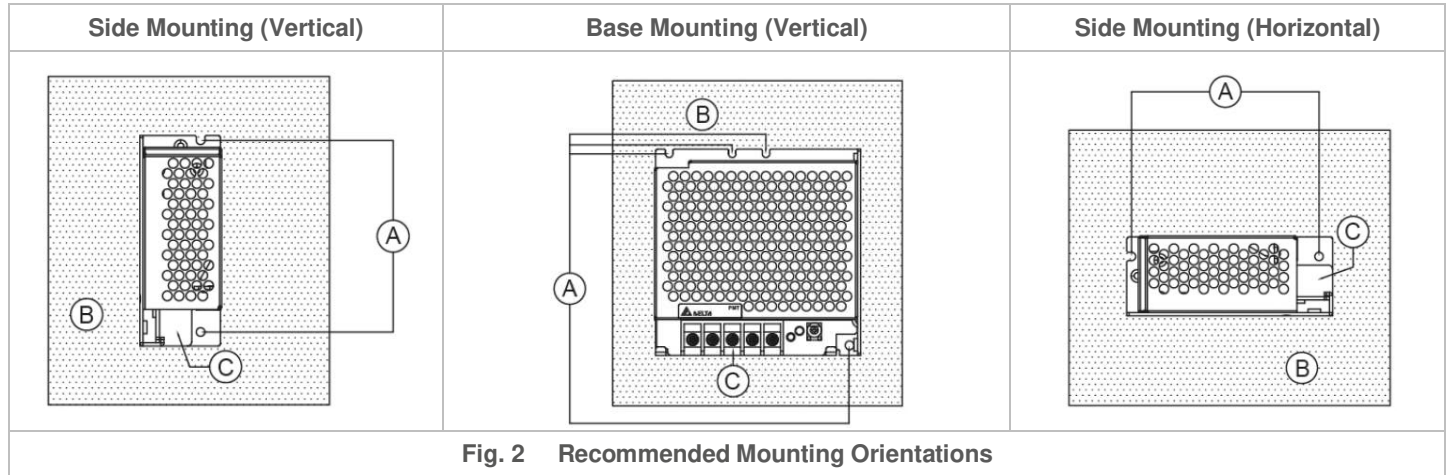

Ensure the mounted device is kept at $\geq 4\text{mm}$ (0.16 inch) safety distance at all sides from other components and equipments. In addition, to ensure sufficient convection cooling, always maintain a distance of $\geq 20\text{mm}$ (0.79 inch) from ventilated surfaces while the device is in operation.

- **PM□-24V50W1AA□ / PM□-24V50W1AG:** Use flexible cable (stranded or solid) of AWG No. 22-12. User should calculate and select the suitable wire specification (type/quantity/diameter) according to actual output current. The torque at the Connector shall not exceed 13 Kgf.cm (11.23 lbf.in). The insulation stripping length should not exceed 0.275" or 7mm (Refer to Fig. 3).
- **PM□-24V50W1AH:** Use flexible cable (stranded or solid) of AWG No. 22-18. Please refer to Table 1 for the recommended Housing and Terminal.

| Table 1 | Connector (Board Mounting) | Housing | Terminal |
|--------------|----------------------------|---------|--------------|
| Input (JST) | B3P5-VH(LF)(SN) | VHR-5N | SVH-21T-P1.1 |
| Output (JST) | B2P3-VH(LF)(SN) | VHR-3N | |

PMT Panel Mount Power Supply

24V 50W 1 Phase / PMT-24V50W1A□

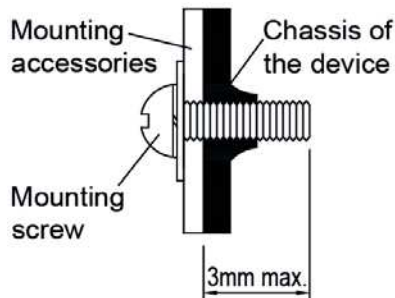

- **For PMT and PML Series (Refer to Fig. 4):** Only use M3 screw ≤ 3 mm (0.12 inch) through the base mounting holes. This is to keep a safe distance between the screw and internal components. Recommended mounting tightening torque: 4~7Kgf.cm (3.47~6.08 lbf.in).
- **For PMB Series: (Refer to Fig. 3):** The mounting holes on any mounting accessories for the device should be kept at a diameter of < 6.5 mm (0.26 inch). This is to ensure sufficient safety distance between the mounting screw and the components around the mounting holes on the PCBA. Therefore, the diameter of the mounting screw should be kept at < 6.5 mm (0.26 inch).

Fig. 4 Mounting Screw

Safety Instructions

- If user's mounting orientation is not according to the recommended mounting orientations, please consult Delta for further information.
- L frame (PML) and Open frame (PMB) options are to be manufactured by Delta and not to be reconfigured by users from the standard enclosed configuration.
- The device is not recommended to be placed on low thermal conductive surface. For example, plastics.
- The enclosure of the device can become very hot depending on the ambient temperature and load of the power supply. Do not touch the device while it is in operation or immediately after power is turned OFF. Risk of burning!
- Do not touch the terminals while power is being supplied. Risk of electric shock.
- Prevent any foreign metal, particles or conductors from entering the device through the openings during installation. It may cause electric shock, safety hazard, fire and/or product failure.
- The power supply must be mounted by metal screws onto a grounded metal surface. It is highly recommended that the Earth terminal on the connector be connected to the grounded surface.
- Warning (For Standard Terminal Block and Front Face Terminal Block products): When connecting the device, secure Earth connection before connecting L and N. When disconnecting the device, remove L and N connections before removing the Earth connection.

Accessories

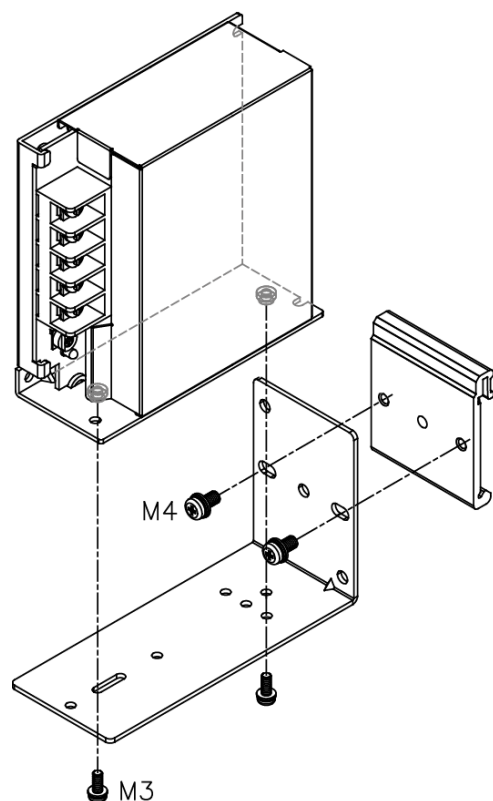

L-01: Latch
P-03: Bracket

These accessories are used to mount the panel mount power supply onto a DIN rail.

PMT Panel Mount Power Supply

24V 50W 1 Phase / PMT-24V50W1A□

Functions

Start-up Time

The time required for the output voltage to reach 90% of its final steady state set value, after the input voltage is applied.

Rise Time

The time required for the output voltage to change from 10% to 90% of its final steady state set value.

Hold-up Time

Time between the collapse of the AC input voltage, and the output falling to 95% of its steady state set value.

■ Graph illustrating the Start-up Time, Rise Time, and Hold-up Time

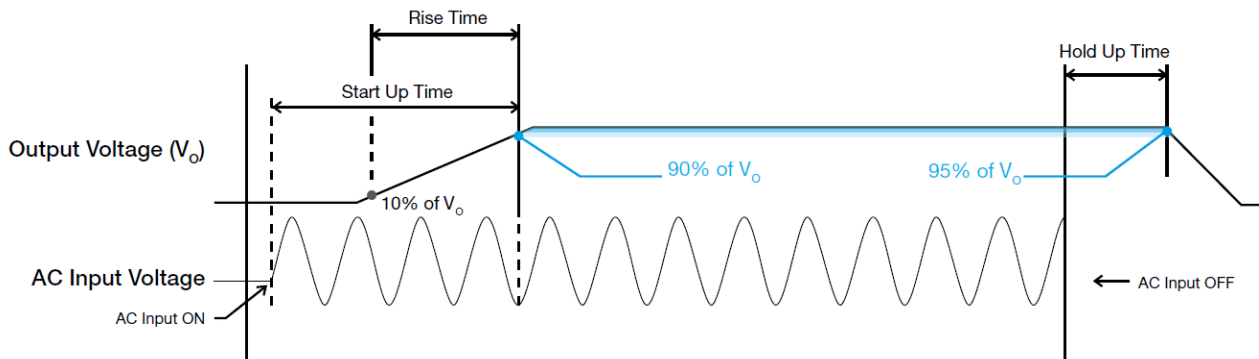

Inrush Current

Inrush current is the peak, instantaneous, input current measured and, occurs when the input voltage is first applied. For AC input voltages, the maximum peak value of inrush current will occur during the first half cycle of the applied AC voltage. This peak value decreases exponentially during subsequent cycles of AC voltage.

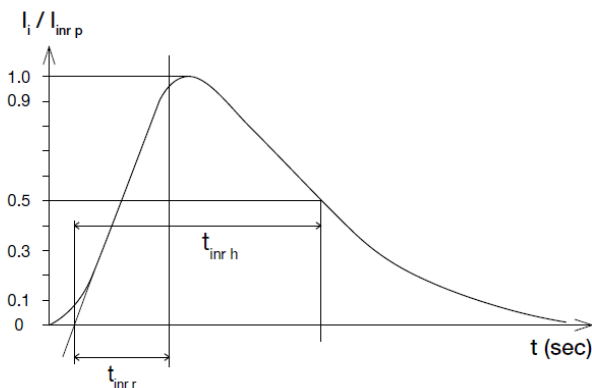

Dynamic Response

The power supply output voltage will remain within $\pm 5\%$ of its steady state value, when subjected to a dynamic load from 0 to 100% of its rated current.

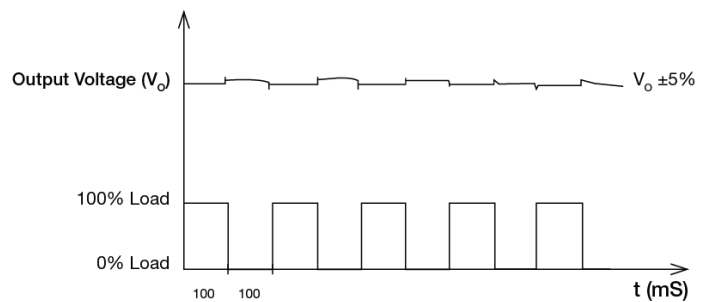

PMT Panel Mount Power Supply

24V 50W 1 Phase / PMT-24V50W1A□

Overload & Overcurrent Protections (Auto-Recovery)

The power supply's Overload (OLP) and Overcurrent (OCP) Protections will be activated when output current exceeds 120% of I_O (Max load). In such occurrence, the V_O will start to droop and once the power supply has reached its maximum power limit, the protection is activated and the power supply will go into "Hiccup mode" (Auto-Recovery). The power supply will recover once the fault condition of the OLP and OCP is removed and I_O is back within the specifications.

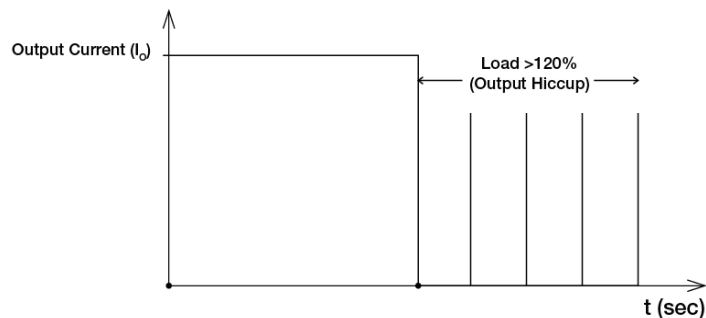

It is not recommended to prolong the duration of I_O when it is <120% but >100%, since it may cause damage to the PSU.

Short Circuit Protection (Auto-Recovery)

The power supply's output OLP/OCP function also provides protection against short circuits. When a short circuit is applied, the output current will operate in "Hiccup mode", as shown in the illustration in the OLP/OCP section on this page. The power supply will return to normal operation after the short circuit is removed.

Overvoltage Protection (Auto-Recovery)

The power supply's overvoltage circuit will be activated when its internal feedback circuit fails. The output voltage shall not exceed its specifications defined on Page 3 under "Protections".

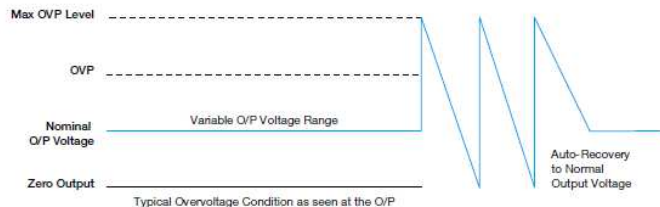

Over Temperature Protection (Auto-Recovery)

As described in load de-rating section, the power supply also has Over Temperature Protection (OTP). In the event of a higher operating temperature at 100% load, the power supply will run into OTP when the operating temperature is beyond what is recommended in the de-rating graph. When activated, the output voltage will go into bouncing mode until the temperature drops to its normal operating temperature as recommended in the de-rating graph.

PMT Panel Mount Power Supply

24V 50W 1 Phase / PMT-24V50W1A□

Operating Mode

■ Redundant Operation

In order to ensure proper redundancy operation for the power supply unit (PSU), ensure that the output voltage difference between the two units is kept at 0.45~0.50V for 24V supplies. Follow simple steps given below to set them up for the redundant operation:

Step 1.

Measure output voltage of PSU 1 and PSU 2. If PSU 1 is the master unit, then V_O of PSU 1 must be higher than PSU 2. In order to set the output voltage, individually connect the power supply to 50% of rated load, and set the PSU 1 and PSU 2 output voltage.

Step 2.

Connect the power supply units PSU 1 and PSU 2 to Vin 1 & Vin 2, respectively, of the DRR-20N (or 20A) module shown on the diagram on the right.

Step 3.

Connect the system load from V_{out} . Please note that output voltage V_{out} from DRR module will be $= V_O$ (output voltage of power supply) $- V_{drop}^*$ (in DRR module).

* V_{drop} will vary from 0.60V to 0.90V (Typical 0.65V) depending on the load current and surrounding air temperature.

■ Parallel Operation

The power supply units (PSUs) can also be used for parallel operation in order to increase the output power. The difference in output voltage between the two units must be kept to within 25mV of each other. This difference must be verified with the same output load connected independently to each unit.

Parameters such as EMI, inrush current, leakage current, PARD, start up time will be different from those on the datasheet, when two units are connected in parallel. The user will need to verify that any differences will still allow the two power supplies connected in parallel will work properly in their product/application.

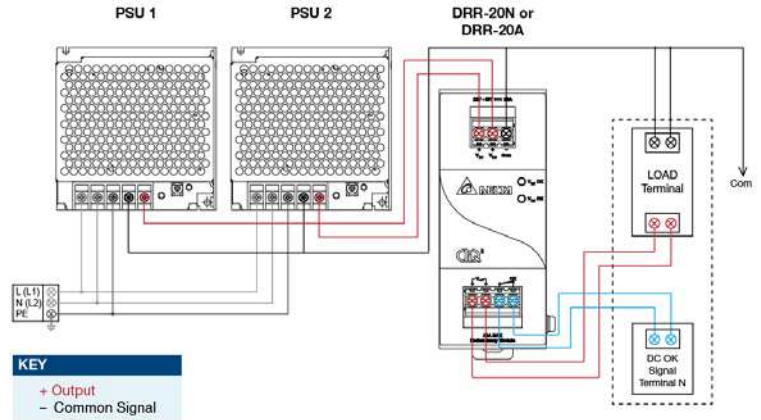

Fig. 5 Redundant Operation Connection Diagram

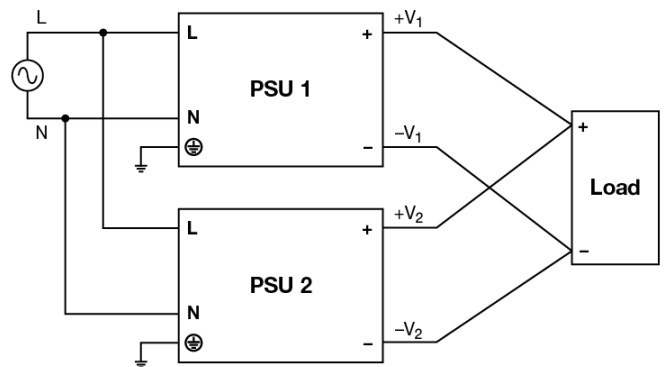

Fig. 6 Parallel Operation Connection Diagram

Others

Delta RoHS Compliant



Restriction of the usage of hazardous substances

The European directive 2011/65/EU limits the maximum impurity level of homogeneous materials such as lead, mercury, cadmium, chrome, polybrominated flame retardants PBB and PBDE for the use in electrical and electronic equipment. RoHS is the abbreviation for "Restriction of the use of certain hazardous substances in electrical and electronic equipment".

This product conforms to this standard.